



Solis Three Phase Inverter

S6-GC(37.5-60)K **Installation and Operation Manual**

Ver 1.0

Ginlong Technologies Co., Ltd.

No. 57 Jintong Road, Binhai Industrial Park, Xiangshan, Ningbo,
Zhejiang, 315712, P.R.China.

Tel: +86 (0)574 6578 1806

Email: info@ginlong.com

Web: www.solisinverters.com

Please adhere to the actual products in case of any discrepancies in this user manual.

If you encounter any problem on the inverter, please find out the inverter S/N
and contact us, we will try to respond to your question ASAP.



Ginlong Technologies Co., Ltd.

1. Introduction	4
1.1 Product Description	4
1.2 Unpacking and storage	5
1.3 Storage	6
1.4 Front Panel Display	6
2. Safety instructions	7
2.1 Safety symbols	7
2.2 General safety instructions	7
2.3 Notice for use	8
2.4 Notice for Disposal	8
3. Installation	9
3.1 Environmental considerations	9
3.1.1 Select a location for the inverter	9
3.1.2 Other environmental considerations	11
3.2 Product handling	11
3.3 Mounting the Inverter	12
3.3.1 Wall mounting	13
3.3.2 Rack mounting	14
3.4 Electrical Connections	17
3.4.1 Grounding	18
3.4.2 Connect PV side of inverter	20
3.4.3 Connect grid side of inverter	22
4. Communication & Monitoring	28
4.1 Inverter monitoring connection	30
4.1.1 Monitoring for a single inverter	30
4.1.2 Monitoring for multiple inverters	31
4.2 Meter Connection	32
5. Commissioning	33
5.1 Preparation	33
5.2 APP Download	33
5.3 Local Connection via APP	34
5.4 Stop the Inverter	36
6. Operation	37
6.1 Home Page	37
6.2 Info Page	38
6.3 Alarm Page	38

6.4 Setting Page	39
6.4.1 Start up and Stop the inverter	40
6.4.2 Inverter Setting	40
6.4.3 Grid Parameter Setting	41
6.4.4 EPM Setting	41
6.4.5 Inverter Work Mode Setting	45
7. Maintenance	46
7.1 Night Time PID-Recovery Function	46
7.2 Fan Maintenance	47
8. Troubleshooting	48
9. Specifications	53

1. Introduction

1.1 Product Description

Solis Three phase Inverters convert DC power from the photovoltaic(PV) array into alternating current(AC) power that can satisfy local loads as well as feed the power distribution grid.

This manual covers the three phase inverter model listed below:

S6-GC3P37.5K04-NV-ND, S6-GC3P40K04-NV-ND, S6-GC3P50K04-NV-ND, S6-GC3P60K05-NV-ND, S6-GC3P50K04-HV-ND, S6-GC3P60K05-HV-ND, S6-GC3P23K03-LV-ND, S6-GC3P25K04-LV-ND, S6-GC3P30K04-LV-ND, S6-GC3P36K04-LV-ND, S6-GC3P37.5K04-LV-ND

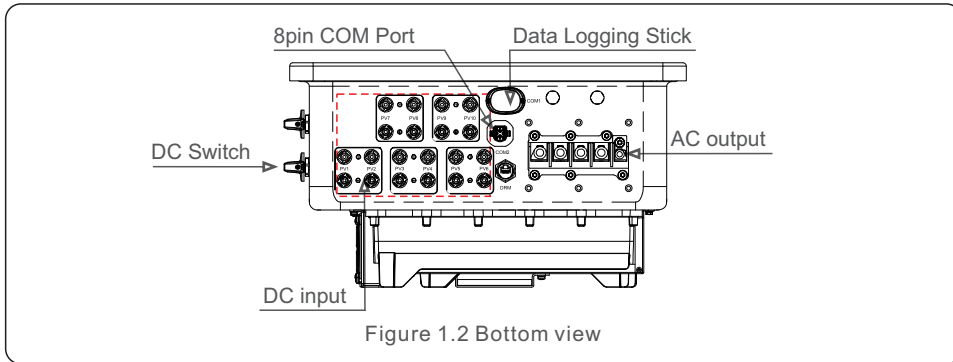
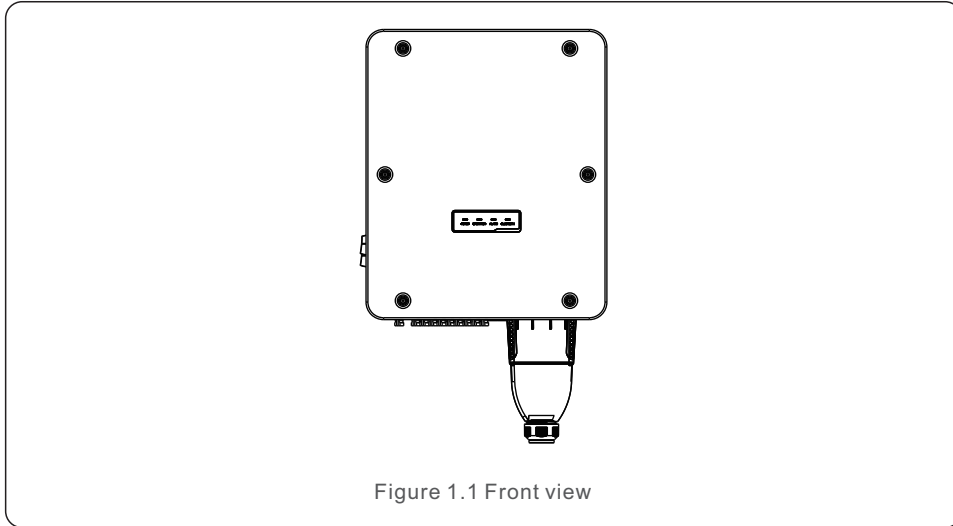

Some models may have a different number of DC inputs, please refer to datasheet/nameplate/ actual product.

1. Introduction

1.2 Unpacking and storage

When you receive the inverter, please ensure that all the parts listed below are included:

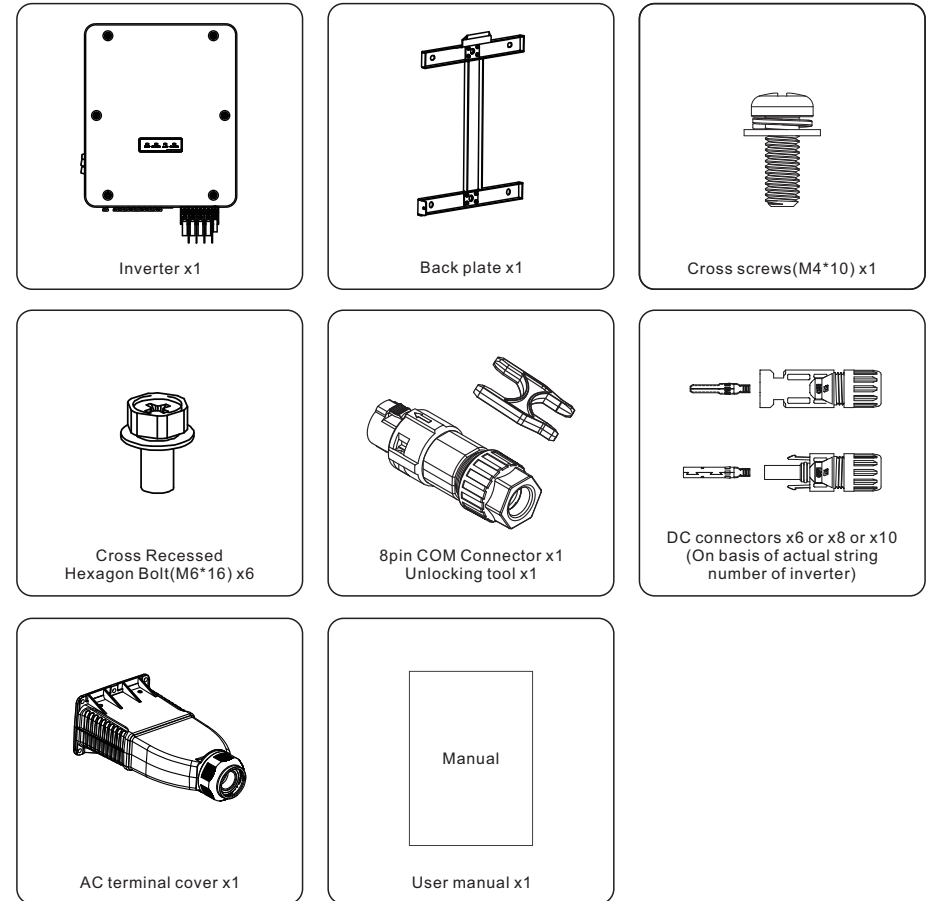

If anything is missing, please contact your local Solis distributor.

1. Introduction

1.3 Storage

If the inverter is not to be installed immediately, storage instructions and environmental conditions are below:

- Use the original box to repackage the inverter, seal with adhesive tape with the desiccant inside the box.
- Store the inverter(s) in a clean and dry place, free of dust and dirt.
- Storage temperature must be between -40°C and 70°C and the humidity should be between 0 and 95% non-condensing.
- Stack no more than four (4) inverters high.
- Keep box(es) away from corrosive materials to avoid damage to the inverter enclosure.
- Inspect packaging regularly. If packaging is damaged (wet, pest damage, etc), repackage the inverter immediately.
- Store the inverter(s) on a flat, hard surface - not inclined or upside down.
- After long-term storage, the inverter needs to be fully examined and tested by qualified service or technical personnel before using.
- Restarting after a long period of non-use requires the equipment to be inspected and, in some cases, the removal of oxidation and dust that has settled inside the equipment will be required.

1.4 Front Panel Display



There are four indicators on the Solis S6-GC3P(37.5-60)K-NV-ND Series Inverter (POWER, OPERATION, ALARM and BLUETOOTH) which indicate the working status of the inverter.

Light	Status	Description
POWER	Red Solid ON	The inverter has detected the DC voltage.
	OFF	The DC input voltage is too low or there is no input voltage.
OPERATION	Green Solid ON	Normally Operating
	OFF	The inverter has stopped generating electricity.
	Green Flashing	The inverter is initializing.
ALARM	Yellow Solid ON	Warning
	OFF	Normally Operating
BLUETOOTH	Blue Solid ON	Bluetooth Port is using
	OFF	Bluetooth Port is not used

2. Safety Instructions

Improper use may result in electric shock hazards or burns. This product manual contains important instructions that are required to be followed during installation and maintenance. Please read these instructions carefully before use and keep them in an easily locatable place for future reference.

2.1 Safety symbols

Safety symbols used in this manual, which highlight potential safety risks and important safety information, are listed below:



WARNING

Symbol indicates important safety instructions, which if not correctly followed, could result in serious injury or death.



NOTE

Symbol indicates important safety instructions, which if not correctly followed, could result in damage to or the destruction of the inverter.



CAUTION, RISK OF ELECTRIC SHOCK

Symbol indicates important safety instructions, which if not correctly followed, could result in electric shock



CAUTION, HOT SURFACE

Symbol indicates safety instructions, which if not correctly followed, could result in burns.

2.2 General safety instructions



WARNING

Do not connect PV array positive (+) or negative (-) to ground – doing so could cause serious damage to the inverter.



WARNING

Electrical installations must be done in accordance with local and national electrical safety standards.



WARNING

To reduce the risk of fire, branch circuit over-current protective devices (OCPD) are required for circuits connected to the Inverter.



CAUTION

The PV array (solar panels) supplies a DC voltage when exposed to light.



WARNING

The inverter can only accept a PV array as a DC input. Using any other type of DC source could damage the inverter.

2. Safety Instructions



CAUTION

Risk of electric shock from energy stored in the inverter's capacitors. Do not remove cover until five (5) minutes after disconnecting all sources of supply have passed, and this can only be done by a service technician. The warranty may be voided if any unauthorized removal of cover occurs.



CAUTION

The inverter's surface temperature can reach up to 75°C. To avoid risk of burns, do not touch the surface when the inverter is operating. Inverter must be installed out of the reach of children.



Please read safety instructions carefully in the manual.



CAUTION

This AFCI device automatically resets and may only be used when allowed by NFPA 70. Photovoltaic DC Arc-Fault Circuit-Protection Type 1.

Arc Fault Circuit interrupter AFCI:

Edition 2011 of the National Electrical Code®, Section 690.11, requires that all PV plants attached to a building are fitted with a means of detecting and interrupting serial electric arcs in the PV wiring and array. An electric arc with a power of 300W or greater must be interrupted by the AFCI in the time specified by UL 1699B. After five arc fault detections in 24 hours, an AFCI-induced shutdown will be triggered. If this event occurs, the inverter must be manually reset. After clearing the source of the fault, the inverter can be powered back on and allowed to resume normal operation.

2.3 Notice for use

The inverter has been constructed according to applicable safety and technical guidelines. Use the inverter in installations that meet the following requirements ONLY:

- 1). The inverter must be permanently installed.
- 2). The electrical installation must meet all the applicable regulations and standards.
- 3). The inverter must be installed according to the instructions stated in this manual.
- 4). The system design must meet inverter specifications.
- 5). The inverter is for industrial/commercial application only.

To start-up the inverter, the Grid Supply Main Switch (AC) must be turned on, BEFORE the DC Switch is turned on. To stop the inverter, the Grid Supply Main Switch (AC) must be turned off before the DC Switch is turned off.

2.4 Notice for Disposal

This product shall not be disposed of with household waste. They should be segregated and brought to an appropriate collection point to enable recycling and avoid potential impacts on the environment and human health. Local rules in waste management shall be respected.

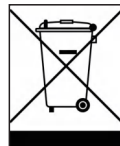

3. Installation

3.1 Environmental considerations

3.1.1 Select a location for the inverter

When selecting a location for the inverter, consider the following:



WARNING: Risk of fire

- Despite careful construction, electrical devices can cause fires.
- Do not install the inverter in areas containing highly flammable materials or gases.
 - Do not install the inverter in potentially explosive atmospheres.
 - The mounting structure where the inverter is installed must be fireproof.

- The temperature of the inverter heat-sink can reach 75°C.
- The inverter is designed to work in an ambient temperature range between -25 to 60°C.
- If multiple inverters are installed on site, a minimum clearance of 500mm should be kept between each inverter and all other mounted equipment. The bottom of the inverter should be at least 500mm above of the ground or floor (see Figure 3.1).
- The LED status indicator lights and the LCD located on the inverter's front panel should not be blocked.
- Adequate ventilation must be present if the inverter is to be installed in a confined space.

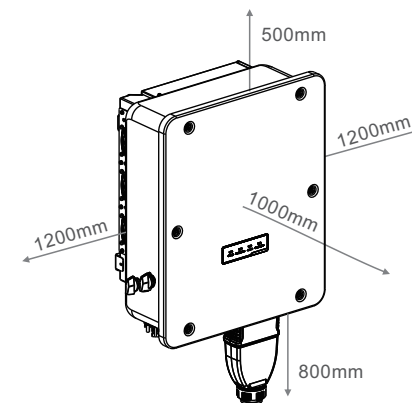

Figure 3.1 Distances required between inverters



NOTE

Nothing should be stored on or placed against the inverter.

3. Installation

When you install multiple inverters, you are advised to install them in horizontal rows. The horizontal installation distance is 1200mm. If multiple inverters are stacked, the following figure shows the installation distance between inverters. When the inverters are installed back-to-back, the distance between the two inverters must be at least 1200mm.

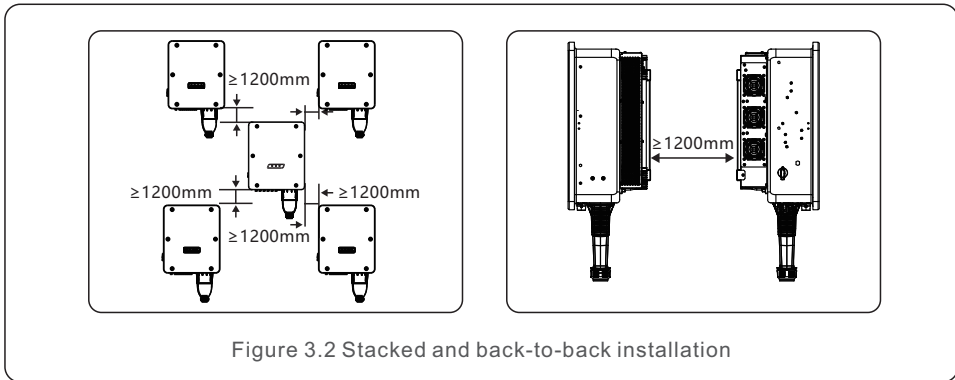

Figure 3.2 Stacked and back-to-back installation

3.1.1.1 Examples of correct and incorrect installations

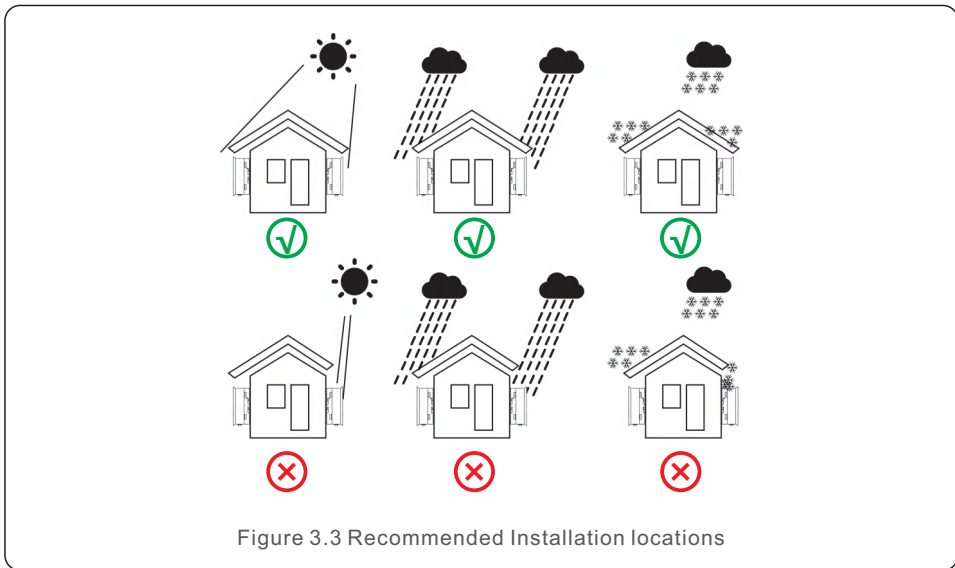

Figure 3.3 Recommended Installation locations

3. Installation

3.1.2 Other environmental considerations

3.1.2.1 Consult technical data

Consult the specifications section (section 10) for additional environmental conditions (protection rating, temperature, humidity, altitude, etc.).

3.1.2.2 Avoiding direct sunlight

Installation of the inverter in a location exposed to direct sunlight should be avoided.

Direct exposure to sunlight could cause:

- Power output limitation (with a resulting decreased energy production by the system).
- Premature wear of the electrical/electromechanical components.
- Premature wear of the mechanical components (gaskets) and user interface.

3.1.2.3 Air circulation

Do not install in small, closed rooms where air cannot freely circulate. To prevent overheating, always ensure that the air flow around the inverter is not blocked.

3.1.2.4 Flammable substances

Do not install near flammable substances. Maintain a minimum distance of three (3) meters (10 feet) from such substances.

3.1.2.5 Living area

Do not install in a living area where the prolonged presence of people or animals is expected. Depending on where the inverter is installed (for example: the type of surface around the inverter, the general properties of the room, etc.) and the quality of the electricity supply, the sound level from the inverter can be quite high.

3.2 Product handling

Please review the instruction below for handling the inverter:

1. The red circles below denote cutouts on the product package. Push in the cutouts to form handles for moving the inverter.

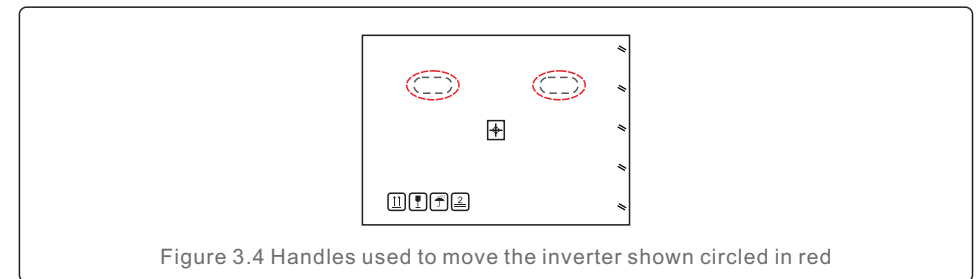

Figure 3.4 Handles used to move the inverter shown circled in red

2. Two people are required to remove the inverter from the shipping box. Use the handles integrated into the heat sink to remove the inverter from the carton.

3. Installation

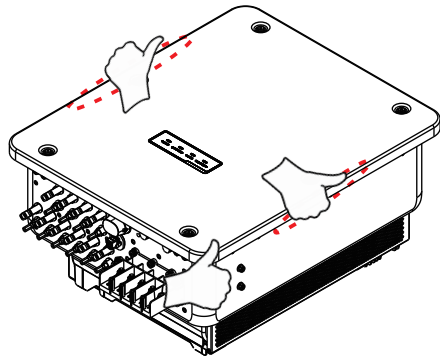

Figure 3.4 Inverter handles



WARNING

Due to the weight of the inverter, contusions or bone fractures could occur when incorrectly lifting and mounting the inverter. When mounting the inverter, take the weight of the inverter into consideration. Use a suitable lifting technique when mounting.

3.3 Mounting the Inverter

The inverter can be mounted to the wall or metal array racking. The mounting holes should be consistent with the size of the bracket or the dimensions shown in Figure 3.5.

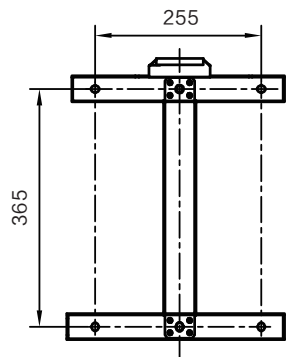

Figure 3.5 Inverter wall mounting

unit:mm

3. Installation

3.3.1 Wall mounting

Refer to figure 3.6 and figure 3.7 Inverter shall be mounted vertically.

The steps to mount the inverter are listed below.

1. Refer to Figure 3.6, drill holes for expansion bolt(M10*90) based on the hole diameter of bracket using a precision drill keeping the drill perpendicular to the wall. Max depth is 90mm.
2. Make sure the bracket is horizontal. And the mounting holes (in Figure 3.6) are marked correctly. Drill the holes into wall at your marks.
3. Use the suitable mounting screws to attach the bracket on the wall.

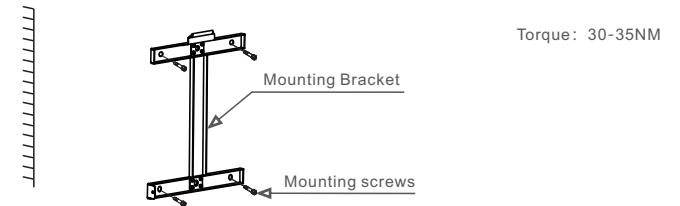

Figure 3.6 Inverter wall mounting

4. Lift the inverter and hang it on the bracket, and then slide down to make sure they match perfectly.

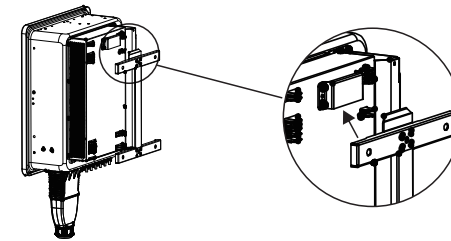

Figure 3.7 Install the inverter

5. Use screws in the packaging to fix the inverter to the mount bracket.

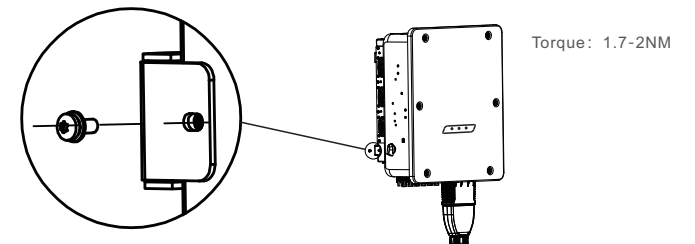

Figure 3.8 Fix the inverter

3. Installation

3.3.2 Rack mounting

The steps to mounted to the rack are listed below:

1. Select a location for the inverter
 - With an IP66 protection rating, the inverter can be installed both outdoors and indoors.
 - When the inverter is running, the temperature of the chassis and heat sink will be higher, Do not install the inverter in a location that you accidentally touch.
 - Do not install the inverter in a place where it is stored in a flammable or explosive material.
2. Installation angle
 - Please install the inverter vertically. If the inverter cannot be mounted vertically, it may be tilted backward to 15 degrees from vertical.

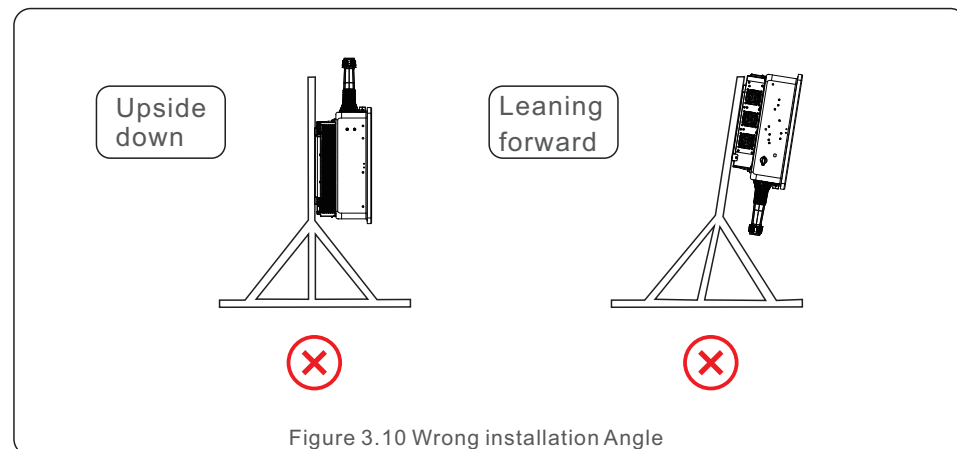
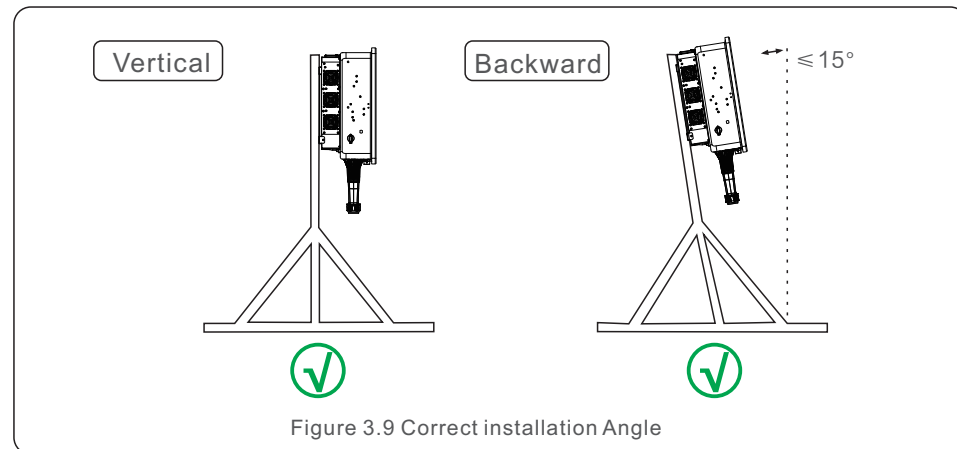

3. Installation

3. Install mounting plate

- 1) Remove the bracket and fasteners from the packaging. Mark the position for hole, drilling according to the hole positions of the bracket.

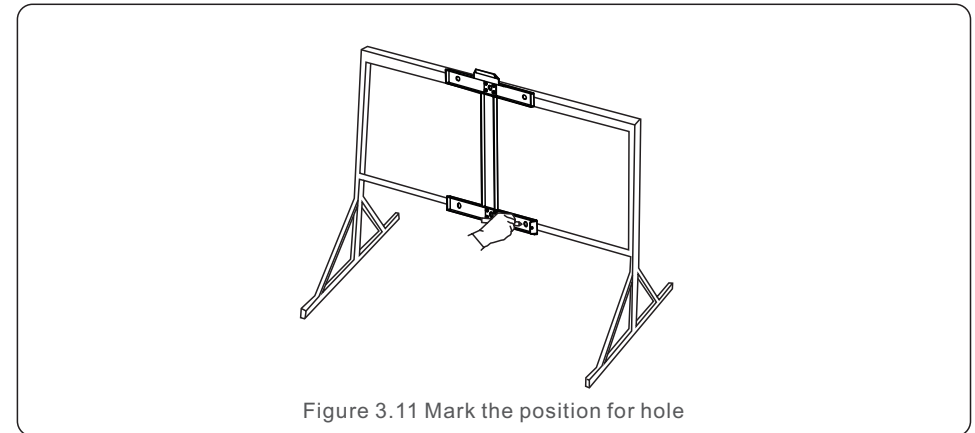

- 2) Drill the marked holes. It is recommended to apply anti-corrosive paint at the hole for corrosion protection.

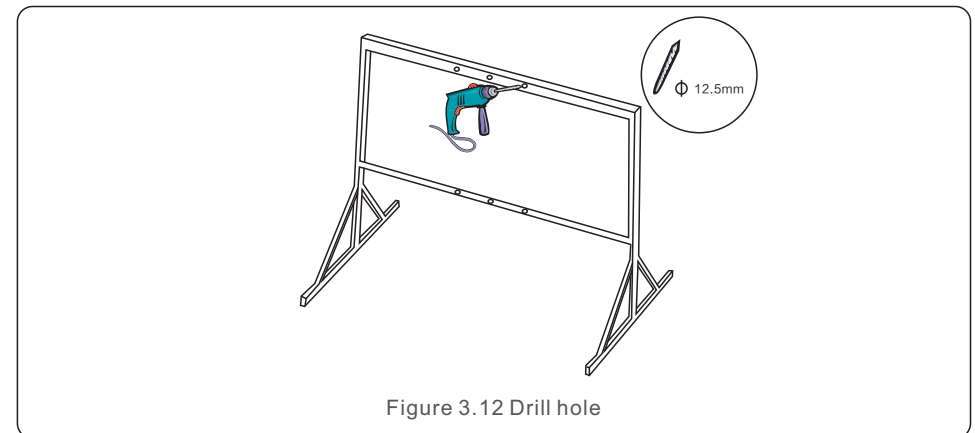

3. Installation

3) Align the mounting plate with the holes, Insert the hexagon bolt (M10X40) through the mounting plate into the hole. Secure the bracket to the metal frame firmly. Torque the nut to 18-23N.m.

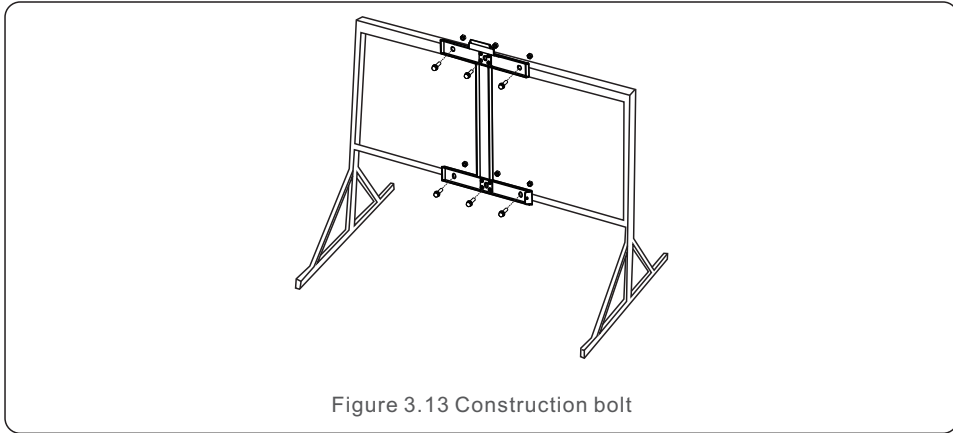

Figure 3.13 Construction bolt

4) Lift the inverter above the bracket and then slide down to make sure they match perfectly.

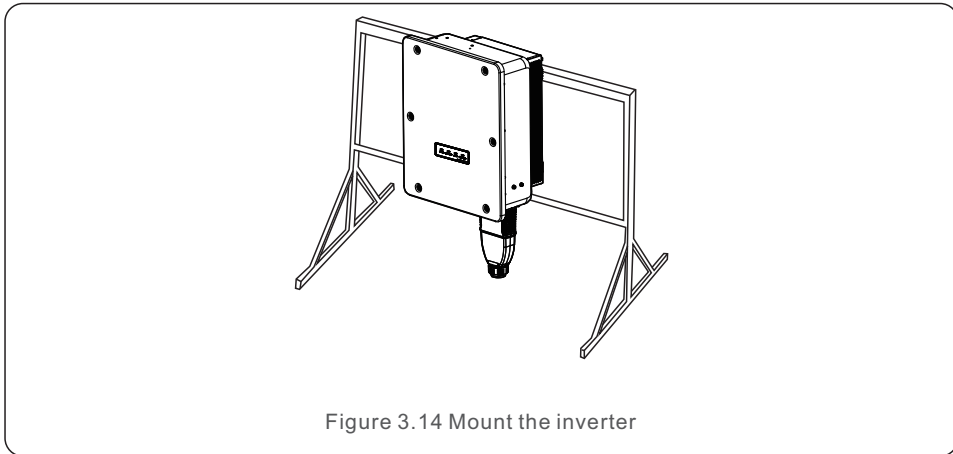

Figure 3.14 Mount the inverter

3. Installation

3.4 Electrical Connections

Inverter design uses PV style quick-connect terminal. The top cover needn't be opened during DC electrical connection. The labels located the bottom of the inverter are described below in table 3.1. All electrical connections are suitable for local or national standard.

Parts	Connection	Cable size	Torque
DC terminal	PV strings	4-6mm ²	NA
Ground terminal	AC ground	16-25mm ²	6-10N.m
Grid terminal	Grid	25-50mm ²	6-10N.m
8pin COM Port	Communication cable	0.75-3mm ²	NA
USB COM Port	Datalogging Stick	NA	NA

Table 3.1 Electrical connection symbols

The electrical connection of the inverter must follow the steps listed below:

1. Switch the Grid Supply Main Switch (AC) OFF.
2. Switch the DC Isolator OFF.
3. Connect the inverter to the grid.
4. Assemble PV connector and connect to the Inverter.

3.4.1 Grounding

To effectively protect the inverter, two grounding methods must be performed.

Connect the AC grounding cable (Please refer to section 3.4.3)

Connect the external grounding terminal.

To connect the grounding terminal on the heat sink, please follow the steps below:

- 1) Prepare the grounding cable: recommend to use the outdoor copper-core cable. The grounding wire should be at least half size of the hot wires.
- 2) Prepare OT terminals: M10.



Important:

For multiple inverters in parallel, all inverters should be connected to the same ground point to eliminate the possibility of a voltage potential existing between inverter grounds.

3. Installation

3) Strip the ground cable insulation to a suitable length(see Figure 3.15).

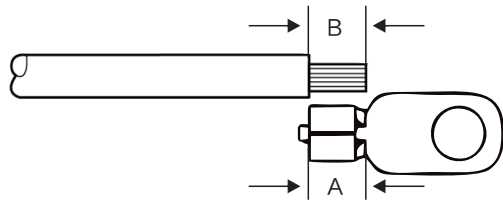

Figure 3.15 Suitable length



Important:

B (insulation stripping length) is 2mm~3mm longer than A (OT cable terminal crimping area) .

4) Insert the stripped wire into the OT terminal crimping area and use the hydraulic clamp to crimp the terminal to the wire (see Figure 3.16).

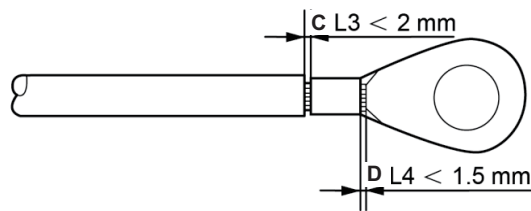

Figure 3.16 Strip wire



Important:

After crimping the terminal to the wire, inspect the connection to ensure the terminal is solidly crimped to the wire.

5) Remove the screw from the heat sink ground point.

6) Connect the grounding cable to the grounding point on the heat sink, and tighten the grounding screw, Torque is 6-10Nm(see figure 3.17).

3. Installation

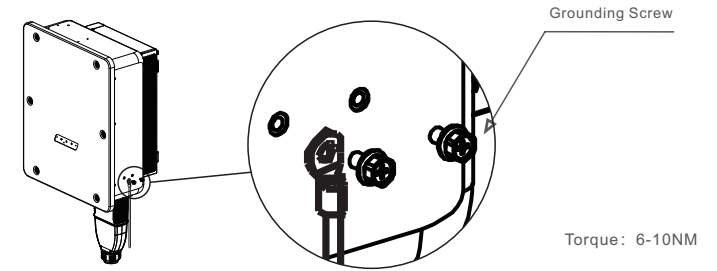

Figure 3.17 Fixed cable



Important:

For improving anti-corrosion performance, after ground cable installed, apply silicone or paint.

Cu-Al Transfer Terminals Dimensional Requirements:

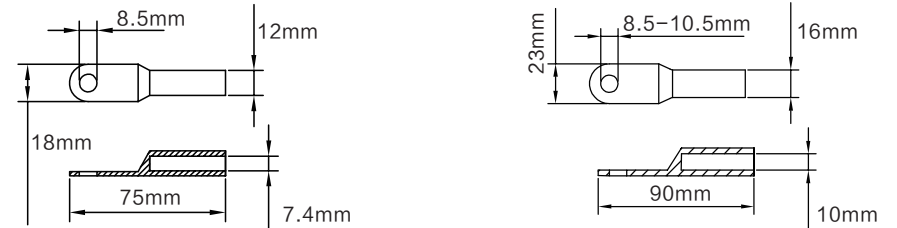

DTL-25 Ground Cu-Al Transfer Terminals

DTL-50 AC Cu-Al Transfer Terminals

Aluminum cables use 50mm² terminals for AC and 25mm² terminals for ground.

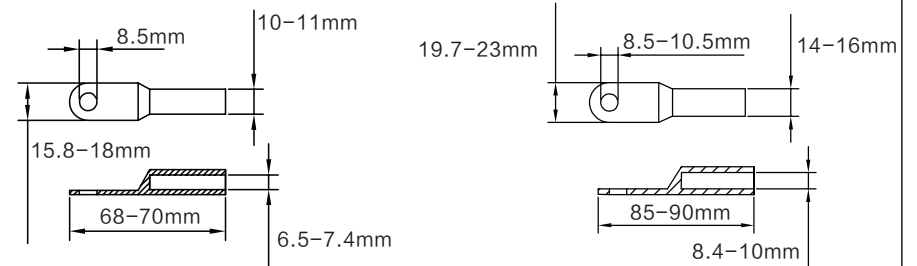

DT-16&DT-25 Cu terminals

DT-35&DT-50 AC Cu-Al Transfer Terminals

Copper cables are suitable for 35-50mm² terminals for AC and 16-25mm² terminals for ground.

3. Installation

3. Installation

3.4.2 Connect PV side of inverter



WARNING

Before connecting the inverter, make sure the PV array open circuit voltage is within the limit of the inverter. Otherwise, the inverter could be damaged.



WARNING

DO NOT connect the PV array positive or PV array negative cable to ground. This can cause serious damage to the inverter!



WARNING

MAKE SURE the polarity of the PV array output conductors matches the DC- and DC+ terminal labels before connecting these conductors to the terminals of the inverter.

Please see table 3.1 for acceptable wire size for DC connections. Wire must be copper only. The steps to assemble the DC connectors are listed as follows:

1. Strip off the DC wire for about 7mm, Disassemble the connector cap nut.
2. Insert the wire into the connector cap nut and contact pin.

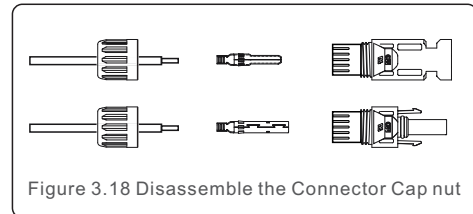

Figure 3.18 Disassemble the Connector Cap nut

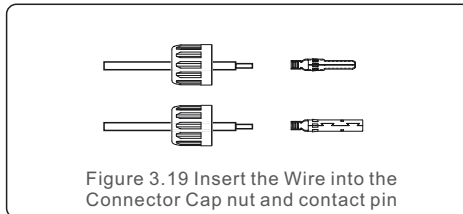

Figure 3.19 Insert the Wire into the Connector Cap nut and contact pin

3. Crimp the contact pin to the wire using a proper wire crimper.
4. Insert metal connector into top of connector, and tighten nut with torque 3-4 Nm.

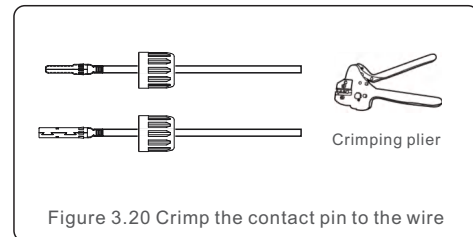

Figure 3.20 Crimp the contact pin to the wire

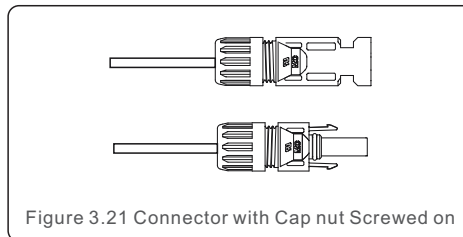

Figure 3.21 Connector with Cap nut Screwed on

5. Measure PV voltage of DC input with multimeter, verify DC input cable polarity (see figure 3.22), and ensure each string voltage is in range of inverter operation. Connect DC connector with inverter until hearing a slight clicking sound indicating successful connection. (see figure 3.23)

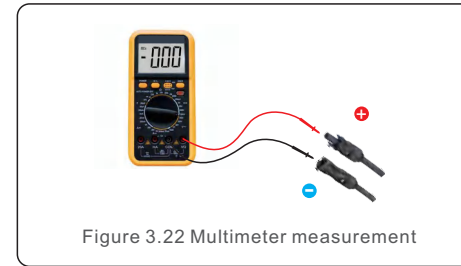

Figure 3.22 Multimeter measurement

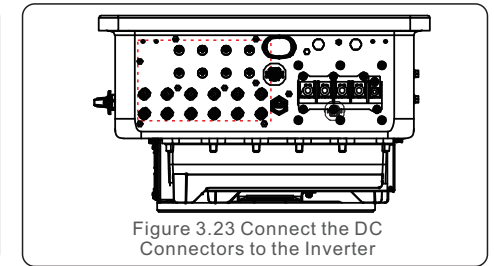

Figure 3.23 Connect the DC Connectors to the Inverter

Cable type	Traverse area (mm ²)		Outside diameter of cable (mm)
	Range	Recommended value	
Industry generic PV cable (model:PV1-F)	4.0~6.0 (12~10AWG)	4.0 (12AWG)	5.5~9.0



CAUTION

If DC inputs are accidentally reversely connected or inverter is faulty or not working properly, it is NOT allowed to turn off the DC switch. Otherwise it may cause DC arc and damage the inverter or even lead to a fire disaster.

The correct actions are:

- *Use a clip-on ammeter to measure the DC string current.
 - *If it is above 0.5A, please wait for the solar irradiance reduces until the current decreases to below 0.5A.
 - *Only after the current is below 0.5A, you are allowed to turn off the DC switches and disconnect the PV strings.
 - * In order to completely eliminate the possibility of failure, please disconnect the PV strings after turning off the DC switch to avoid secondary failures due to continuous PV energy on the next day.
- Please note that any damages due to wrong operations are not covered in the device warranty.

Requirements for the PV modules per MPPT input:

- All PV modules must be of the same type and power rating.
- Please ensure the PV strings are evenly connected to the inverter and try to utilize all the MPPT trackers.
- All PV modules must be aligned and tilted identically.
- The open-circuit voltage of the PV array must never exceed the maximum input voltage of the inverter, even at the coldest expected temperature. (see section 10 "Specifications" for input current and voltage requirements)
- Each string connected to a single MPPT must consist of the same number of series-connected PV modules.

3. Installation

3. Installation

3.4.2.1 DC connection high voltage danger notice



CAUTION
RISK OF ELECTRIC SHOCK

Do not touch an energized DC conductor. There are high voltages present when PV modules are exposed to light causing a risk of death due to an electric shock from touching a DC conductor!

Only connect the DC cables from the PV module to the inverter as described in this manual.



CAUTION
POTENTIAL DAMAGE TO THE INVERTER DUE TO OVERVOLTAGE

The DC input voltage of the PV modules must not exceed the maximum rating of the inverter. (see section 10 “Specifications”)

Check the polarity and the open-circuit voltage of the PV strings before connecting the DC cables to the inverter.

Confirm proper string length and voltage range before connecting DC cable to the inverter.

3.4.3 Connect grid side of inverter



WARNING
An over-current protection device must be used between the inverter and the grid.

1. Connect the three (3) AC conductors to the three (3) AC terminals marked “L1”, “L2” and “L3”. Refer to local code and voltage drop tables to determine the appropriate wire size and type.
2. Connect the grounding conductor to the terminal marked “PE” (protective earth, the ground terminal).

Over-Current Protection Device (OCPD) for the AC side

To protect the inverter's AC connection line, we recommend installing a device for protection against over-current and leakage, with the following characteristics noted in Table 3.2:



NOTE
Use AL-CU transfer (bi-metallic) terminal or anti-oxidant grease with aluminum cables and terminals.

Inverter	Rated voltage(V)	Rated output current (Amps)	Current for protection device (A)
S6-GC3P37.5K04-NV-ND	220/380	57.0	80
S6-GC3P40K04-NV-ND	220/380,230/400	60.8/57.7	80
S6-GC3P50K04-NV-ND	220/380,230/400	76.0/72.2	100
S6-GC3P60K05-NV-ND	220/380,230/400	91.2/86.6	125
S6-GC3P50K04-HV-ND	480	60.1	80
S6-GC3P60K05-HV-ND	480	72.2	100
S6-GC3P23K03-LV-ND	220/230	60.4/57.7	80
S6-GC3P25K04-LV-ND	220/230	65.6/62.8	100
S6-GC3P30K04-LV-ND	220/230	78.7/75.3	100
S6-GC3P36K04-LV-ND	220/230	94.5/90.4	125
S6-GC3P37.5K04-LV-ND	220	98.4	125

Table 3.2 Rating of grid OCPD

3.4.3.1 Connecting the inverter to the utility grid

All electrical installations must be carried out in accordance with the local standards and the National Electrical Code® ANSI/NFPA 70 or the Canadian Electrical Code® CSA C22.1. The AC and DC electric circuits are isolated from the enclosure. If required by section 250 of the National Electrical Code®, ANSI/NFPA 70, the installer is responsible for grounding the system.

The grid voltage must be within the permissible range. The exact operating range of the inverter is specified in section 10 “Specifications”.

3. Installation

3.4.3.2 Wiring procedure



CAUTION
RISK OF ELECTRIC SHOCK. Prior to starting the wiring procedure, ensure that the three-pole circuit breaker is switched off and cannot be reconnected.



NOTE
Damage or destruction of the inverter's electronic components due to moisture and dust intrusion will occur if the enclosure opening is enlarged.



CAUTION
Risk of fire if two conductors are connected to one terminal. If a connection of two conductors to a terminal is made, a fire can occur.
NEVER CONNECT MORE THAN ONE CONDUCTOR PER TERMINAL.



NOTE
Use M8 crimp terminals(M6 for PE) to connect to the inverter AC terminals.

Cable specification		Copper cable	Aluminum cable
Traverse cross sectional area (mm ²)	Range	35-50	50-70
	Recommended	50	70
Cable outer diameter (mm)	Range	37-44	37-46
	Recommended	44	46



NOTE
Considering max 3% AC voltage drop, if AC cable length is below the parameter in following diagram, the recommended 50mm² AC cable can be used. If AC cable length is higher, please consider to use AC cable with larger cross-sectional area. Max 3% AC voltage drop is for reference only, please follow the local electrical regulation to calculate the suitable AC cable specification.

3. Installation

Inverter	Maximum AC cable length(m)
S6-GC3P37.5K04-NV-ND	325
S6-GC3P40K04-NV-ND	305
S6-GC3P50K04-NV-ND	245
S6-GC3P60K05-NV-ND	200
S6-GC3P50K04-HV-ND	350
S6-GC3P60K05-HV-ND	290
S6-GC3P23K03-LV-ND	175
S6-GC3P25K04-LV-ND	160
S6-GC3P30K04-LV-ND	135
S6-GC3P36K04-LV-ND	110
S6-GC3P37.5K04-LV-ND	105

Table 3.3 Recommended max AC cable length

1. Strip the end of AC cable insulating jacket about 125-150mm then strip the end of each wire.

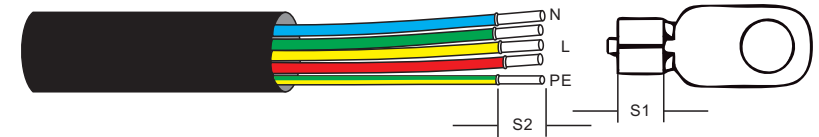

Figure 3.24 Strip AC cable



NOTE
S2 (insulation stripping length) is 2mm-3mm longer than S1.
(OT cable terminal crimping area)

2. Leave the AC breaker disconnected to ensure it does not close unexpectedly.
3. Remove the 4 screws on the inverter junction box, and then remove the AC cable cover.
4. Unscrew the nut and route the cable through the nut, sheath, and AC terminal cover.
5. Strip off the insulation layer of the cable and pass through the cable crimping area of the OT terminal. Crimp the terminal using a hydraulic crimping tool (OT terminal M8 ,torque 6-10Nm). The crimped part of the terminal must be insulated with a heat shrink tube or insulation tape.
6. Cable Gland are recommended torque for installation is 12Nm. In order to ensure waterproof effect, operator should regularly check whether the installation is tight.

3. Installation

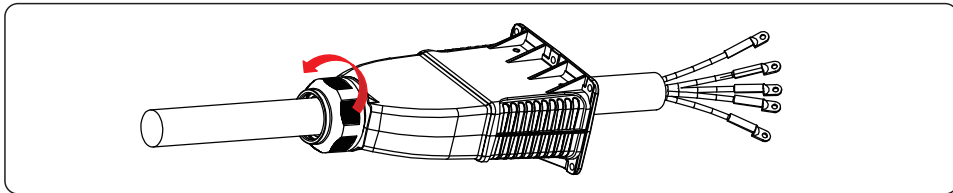

NOTE

If aluminum cables are used, use Cu-Al Transfer Terminals to prevent direct contact between copper bars and aluminum cables (The Cu-Al Transfer Terminals is configured according to the selected cable).

7. Secure the cable connection to the AC terminal using a socket wrench. Tighten the screws on the junction box.

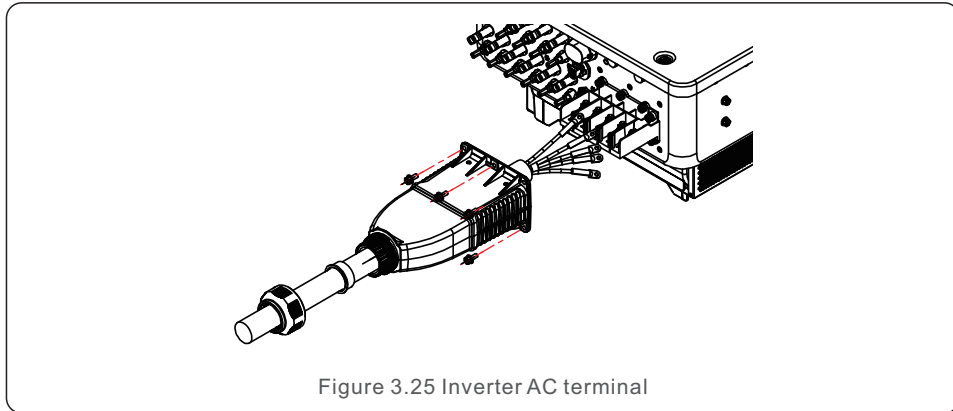

Figure 3.25 Inverter AC terminal

OT Terminal specification: M8

OT Terminal torque: 6-10Nm

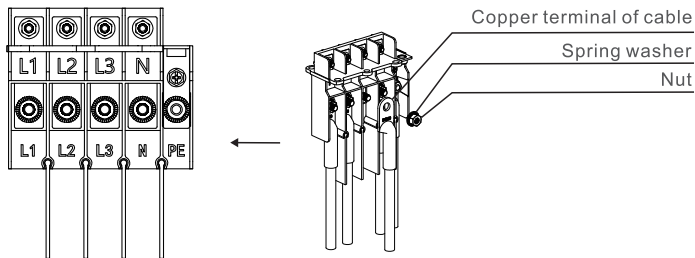

Figure 3.26 Copper aluminum transfer terminal

8. Tighten the screws on the junction box.

4. Comm. & Monitoring

There are 2 communication ports on the inverter. One is a USB COM port and the other is a 8-Pin COM port. The USB COM port is used to connect Solis datalogging sticks (Please refer to manuals of Solis datalogging sticks for details). There are 2 communication ports on the inverter. One is a USB COM port and the other is a 8-Pin COM port. The USB COM port is used to connect Solis datalogging sticks (Please refer to manuals of Solis datalogging sticks for details).

The 8-Pin COM port is used for multiple inverter daisy chain connection/ Logic Interface Connection/ Meter connection.

The inverter package will include a 8-Pin COM connector to be used on this 8-Pin COM port. The Pin definition is shown below. Facing the connector, Pin 1 is on the left of the first row. The rest polarity is showing in below diagram.

The inverter package will include a 8-Pin COM connector to be used on this 8-Pin COM port. The Pin definition is shown below. Facing the connector, Pin 1 is on the left of the first row. The rest polarity is showing in below diagram.

Pin	Definition	Description
1	RS485-1A IN	PIN1, 2, 4, 5 2 Pairs of RS485-1 Used for hand-by-hand connection with EPM device
2	RS485-1B IN	
3	GND	PIN3, 6 GND of communication PIN For Grounding of the EPM or other device
4	RS485-1A OUT	
5	RS485-1B OUT	PIN7, 8 RS485-2 or METER (as default)
6	GND	
7	METER-A/RS485-2A	
8	METER-A/RS485-2B	

Figure 4.1 8pin COM Connector

4. Comm. & Monitoring

The following is the assembly diagram of the 8-Pin COM connector.

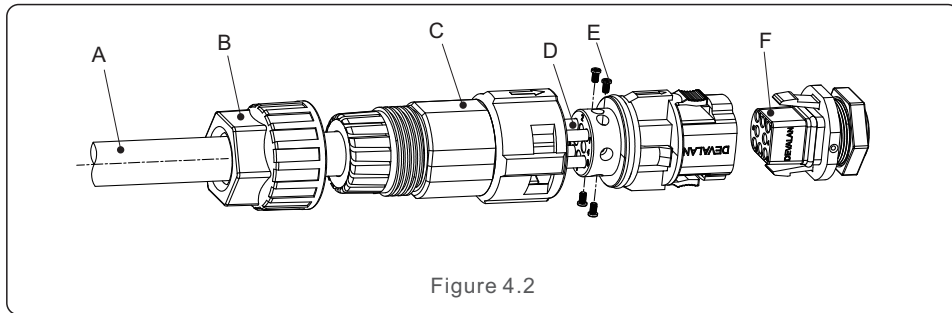

- A-Main cable (Diameter: 4-6mm)
- B-Locking Nut (Torque: 3.5-4N.m)
- C- Sleeve
- D-COM Wire (Dimension: 0.75-3mm², stripping length: 10-12mm)
- E-Locking Screw (Torque: 0.4-0.6N.m)
- F-Connector

Connect Steps:

1. Lead the main cable through the locking nut and the sleeve.
2. Strip the COM wires and insert into corresponding pin terminals. Then fasten the locking screws for the pin terminals.
3. Push the sleeve onto the connector and fasten the locking nut on the end of the sleeve.
4. Connect the connector to the 8-Pin COM port at the bottom of the inverter.

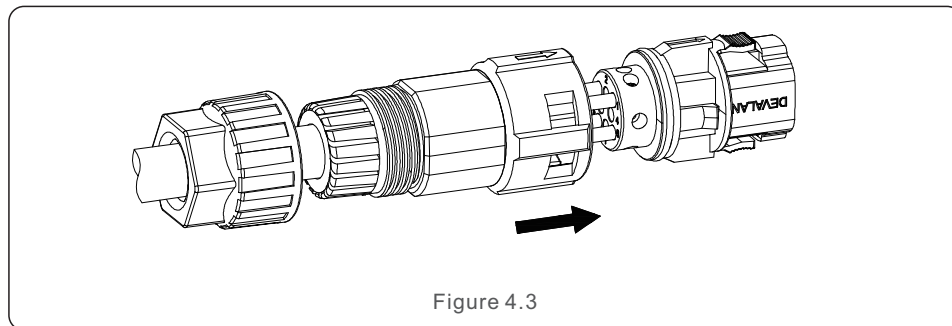

4. Comm. & Monitoring

Disconnect Steps:

1. Press the button on both sides of the connector and pull the connector to disconnect from the COM port.

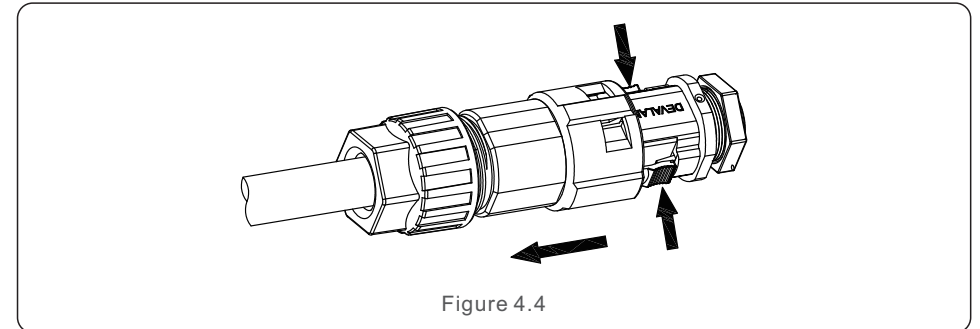

2. Use the unlock tool to insert into the groove on the sleeve and pull the sleeve to disconnect from the connector.

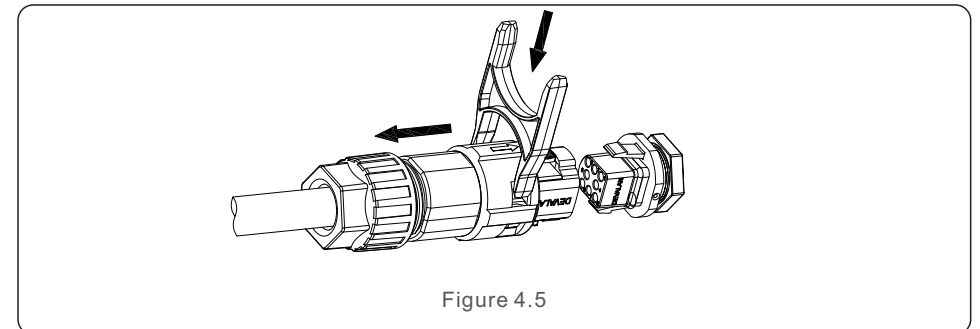

4.1 Inverter monitoring connection

Solis can provide optional accessories such as one-to-one datalogging sticks including WiFi stick, GPRS stick and LAN stick for the monitoring of a single inverter or one-to-multiple datalogging boxes including WiFi box and GPRS Box for the monitoring of multiple inverters. Please refer to corresponding manuals for details.

4.1.1 Monitoring for a single inverter

Every inverter can connect a Solis one-to-one datalogging stick for remote monitoring purpose. The datalogging stick should be directly connected to the USB COM port at the bottom of the inverter. It is a simple plug and play design with fast installation time. Details and the rest configuration process please refer to the datalogging stick manual.

4. Comm. & Monitoring

4.1.2 Monitoring for multiple inverters

When multiple inverters need to run daisy chain communication together, Pin1/2 and Pin4/5 of the 8-Pin COM Port can be used.

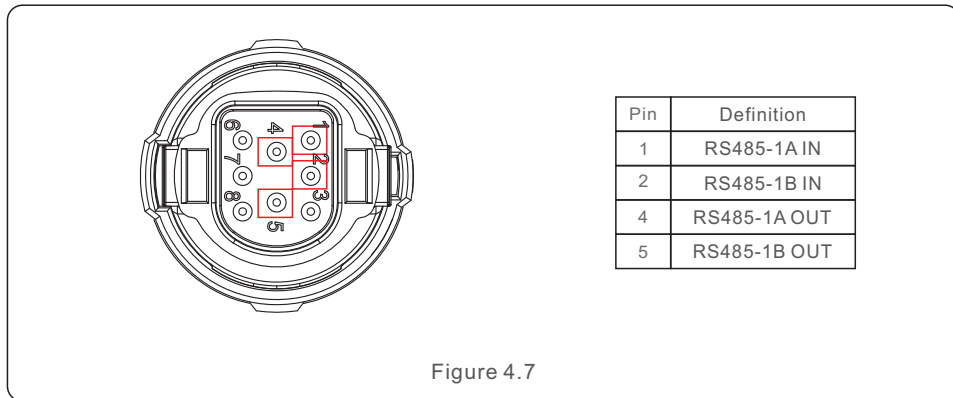
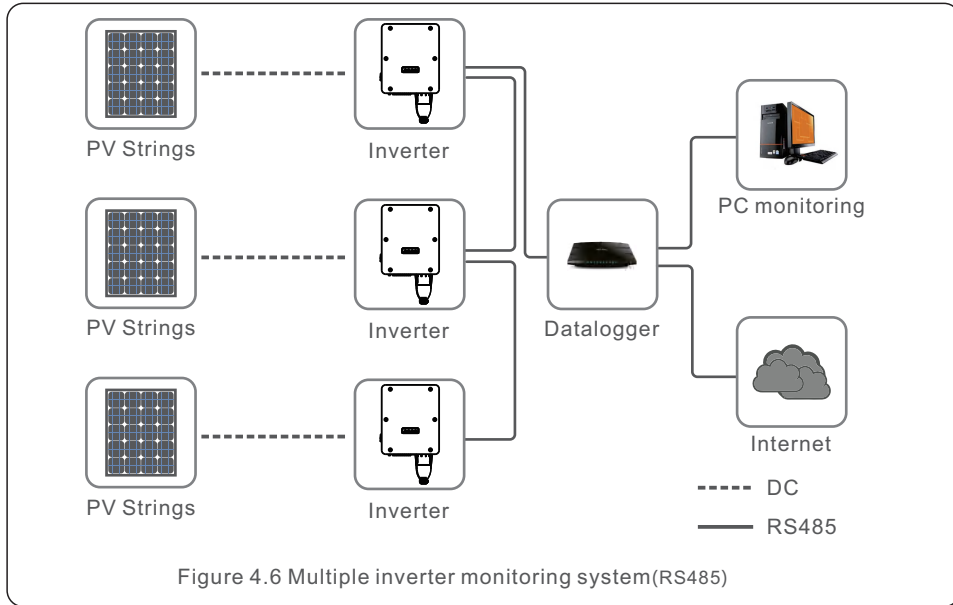

The bus RS485 cable can run into a Solis one-to-multiple datalogging box or any compatible 3rd party monitoring devices, PPC or plant SCADA.

4. Comm. & Monitoring

4.2 Meter Connection

The inverter can work with a three phase smart meter to achieve Export Power Management function and/or 24hour consumption monitoring function.

Two types of meters are supported:

Acrel smart meter: DTSD1352-C.

Eastron smart meter: SDM630MCT(40mA)-3CT.

Customer can place the order for a suitable meter from Solis Sales Reps.

The Pin 7 and Pin 8 of the 8-Pin COM port are used for Meter communication.

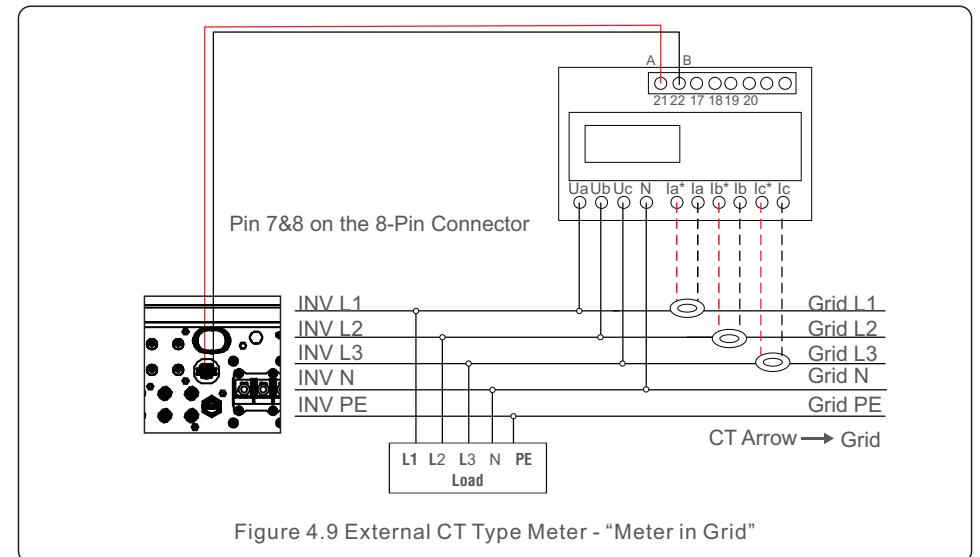
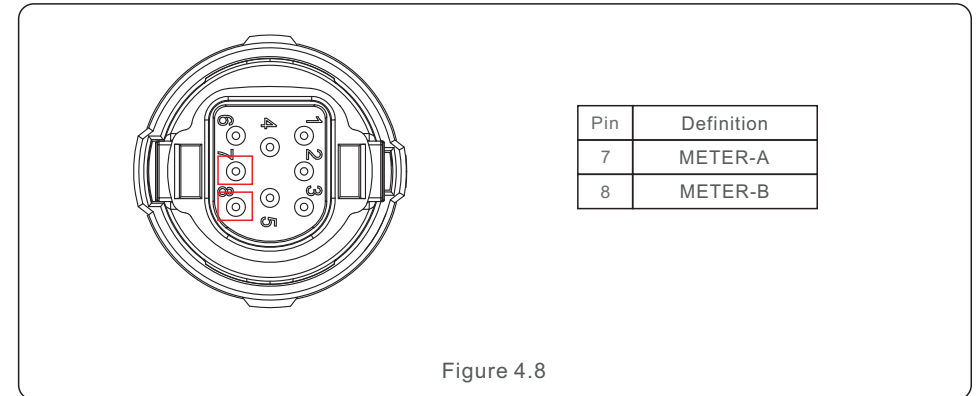

4. Comm. & Monitoring

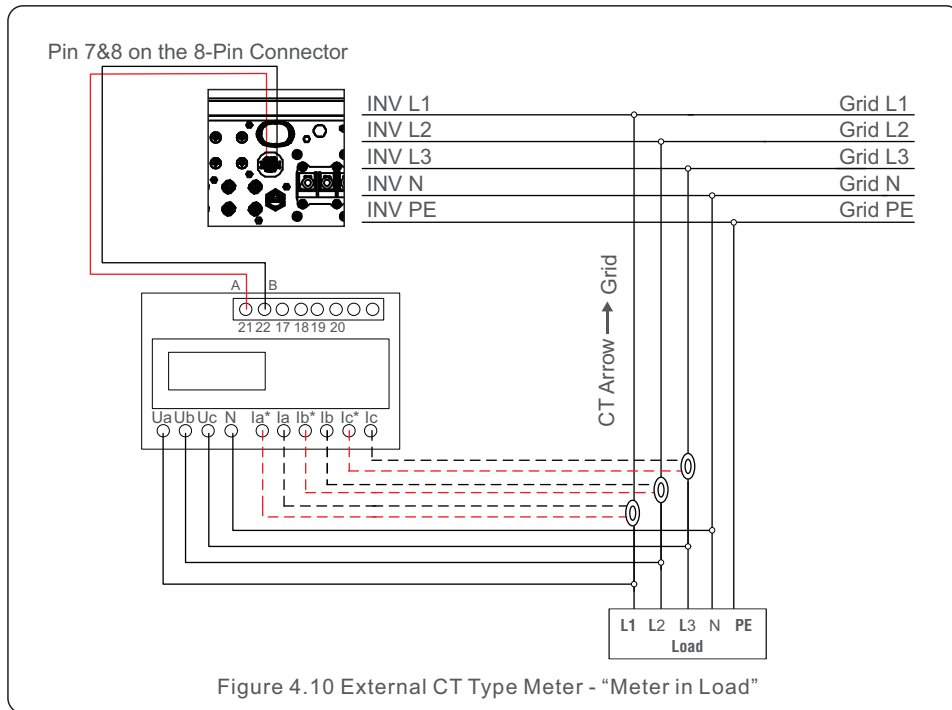

5. Commissioning

5.1 Preparation

- Ensure all the devices are accessible for operation, maintenance and service.
- Check and confirm that the inverter is firmly installed.
- Space for ventilation is sufficient for one inverter or multiple inverters.
- Nothing is left on the top of the inverter.
- Inverter and accessories are correctly connected.
- Cables are routed in safe place or protected against mechanical damage.
- Warning signs and labels are suitably affixed and durable.
- An Android or IOS mobile phone with Bluetooth function is available.
- Measure DC voltage of PV strings and ensure the polarity is correct.
- Measure AC voltage and frequency and ensure they are within local standard.

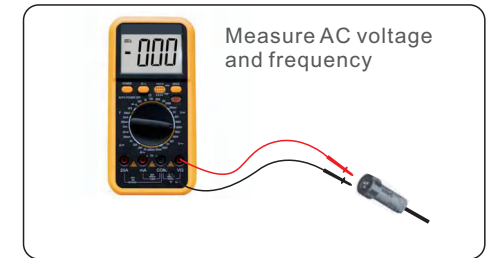
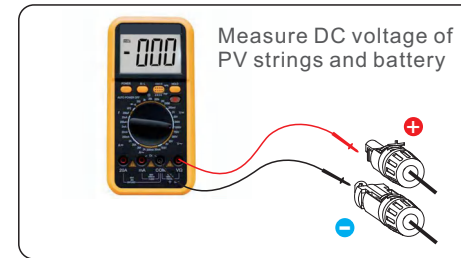

5.2 APP Download

Users need to download the APP before installing it for the first time.

There are three ways to download and install the latest APP:

1. You can visit www.soliscloud.com to download the latest version APP.
2. You can search "Soliscloud" in Google Play or App Store.
3. You can scan this QR code below to download "Soliscloud".



5. Commissioning

5.3 Local Connection via APP

Step 1: **Rotate the inverter DC switch from OFF to ON.**

Step 2: **APP Bluetooth connection with inverter.**

Turn on Bluetooth switch on your mobile phone and then open the Soliscloud APP.

Click "More Tools"->"Local Operation"->"Connect with Bluetooth"

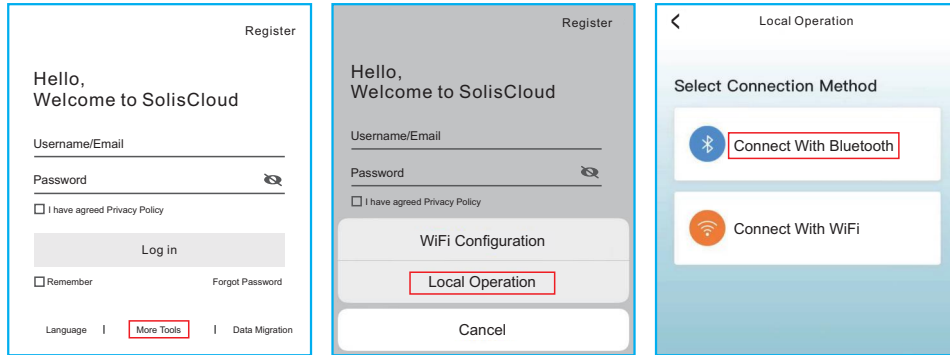

Select the Bluetooth signal from the inverter. (Bluetooth Name: INV-Inverter SN)

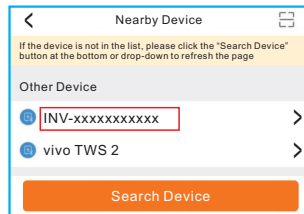

Step 3: **Login account.**

If you are the installer, please select the account type as Installer. If you are the plant owner, please select the account type as owner. Then set your own initial password for control verification. (The first log-in must be finished by installer in order to do the initial set up)

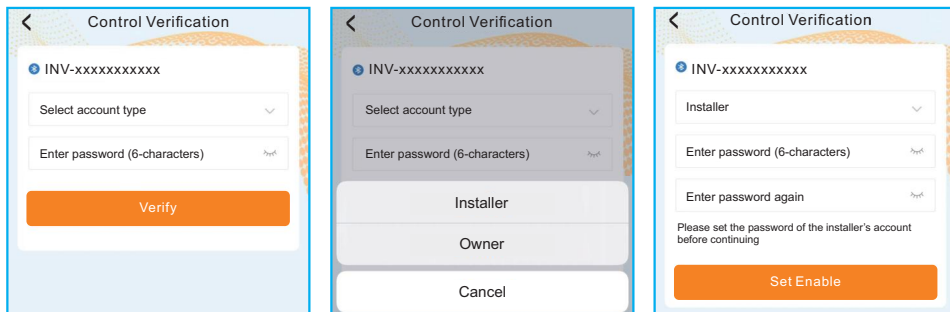

5. Commissioning

Step 4: **Grid Code Setting.**

After login in, the grid code setting will pop up.

Select "Confirm" will automatically choose the "Custom50" by default.

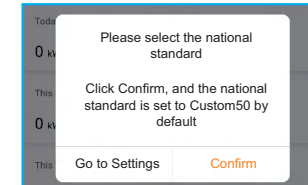

If the default standard doesn't meet the local grid requirement:

Select "**Settings->Grid Parameter Setting->Grid Code Setting->Grid Code**", choose the applicant standard according to the installation and save.

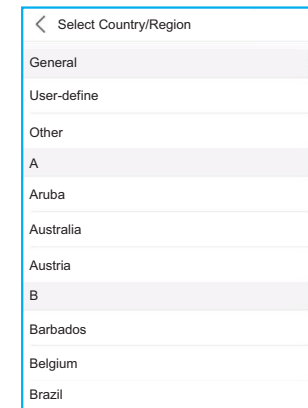

5. Commissioning

The specific parameters can be set at Grid Code Setting page. Mention that the grid parameters modification should be permissible by utility grid company or the power distribution supplier.

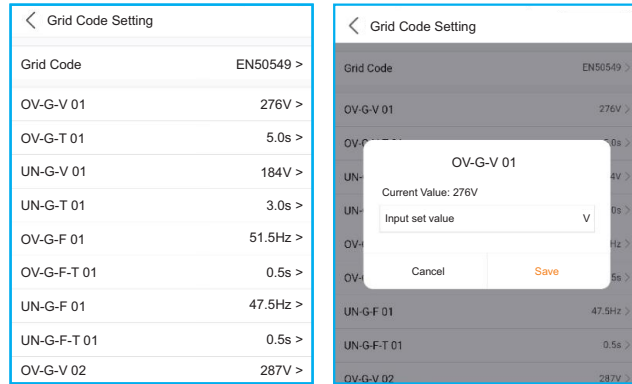

Step 5: Turn on the AC switch between the inverter and Grid, wait till the inverter start generating.

5.4 Stop the Inverter

To stop the inverter, it is mandatory that the steps below are followed in the exact order outlined.

1. Select "Power OFF" in the APP.
2. Turn off the AC Switch between Solis inverter and Grid.
3. Wait approximately 30 seconds (during this time, the AC side capacitors are dissipating energy). If the inverter has DC voltage above the start-up threshold, the red POWER LED will be lit. Switch the DC switch OFF.
4. Confirm all LED's switch OFF (~one (1) minute).



CAUTION

Although the inverter DC disconnect switch is in the OFF position and all the LED's are OFF, operators must wait five (5) minutes after the DC power source has been disconnected before opening the inverter cabinet. DC side capacitors can take up to five (5) minutes to dissipate all stored energy.

6. Operation

The APP interface contains 4 sections:

1. Home
2. Info
3. Alarm
4. Settings

6.1 Home Page

The home page contains the power and energy data of the inverter. The PV data and AC data are also available under this section.

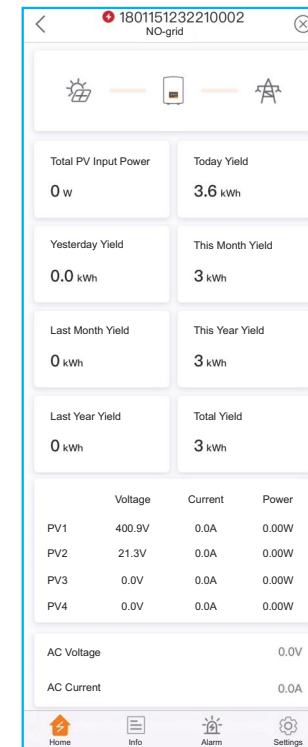

6. Operation

6.2 Info Page

Info page displays the general information of the inverter such as inverter serial number, firmware version, grid code, etc.

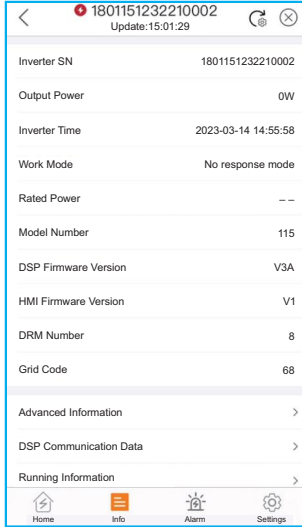

6.3 Alarm Page

Alarm page contains the alarm code of the inverter and its corresponding troubleshooting methods.

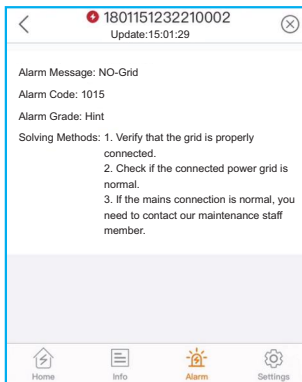

6. Operation

6.4 Setting Page

Setting page contains all the setting options of the inverter.

Functions	Setting Path
Switch on/off the inverter	Settings -> "Power ON" & "Power OFF"
Change inverter time setting	Settings -> Inverter Setting-> Inverter Parameter Setting -> Inverter Time Setting
Change inverter output power percentage or power factor	Settings -> Inverter Setting-> Inverter Power Setting
Set grid code and protection parameters	Settings -> Grid Parameter Setting -> Grid Code Setting
Set Export Power control	Settings -> EPM Setting
Set grid code related working modes	Settings -> Inverter Work Mode Setting -> Work Mode

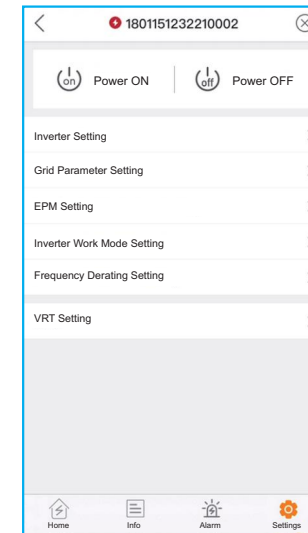

NOTE:

The inverter is by default setting with grid code which complies with local requirements. If there is need to modify the protection limits, please consult and approve by your local grid operator.

6. Operation

6. Operation

6.4.1 Start up and Stop the inverter

1. Select "Settings -> Power ON" to start up the inverter.
2. Select "Settings -> Power OFF" to stop the inverter.

6.4.2 Inverter Setting

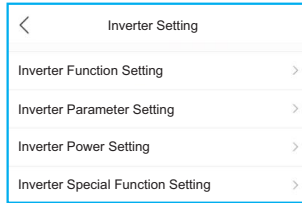

6.4.2.1 Inverter Function Setting

1. AFCI Setting

The inverter has a arc fault shutdown function. Solis inverters have the built-in AFCI function which can detect the arc fault on the DC circuit and shut down the inverter to prevent a fire disaster.

Setting	Description
AFCI Protect	Set the inverter AFCI function ON/OFF.
Arc-Fault Manual Reset	When Arc-Fault error happens more than 5 times, inverter will stop generating. Users have to check the inverter connection is OK and make a manual reset operation using this switch.

2. 24-Hour Load Monitoring

Turn on this switch to enable 24-Hour Load Monitoring function. Please refer to 6.4.4.1 Built-in EPM Setting for details.

3. MPPT Multi-peak Scanning Setting

Setting	Description
MPPT Multi-peak Scanning Switch	Set the function ON/OFF.
MPPT Multi-peak Scan Interval	The inverter will carry out Multi-peak MPPT scanning 1 time every scan interval.

4. Logical Interface Setup

Setting	Description
Logic Interface(DRM) Switch	Set the function ON/OFF.
P_Limit DI 1 ~ P_Limit DI 4	Set the AC output power under different DI.

6.4.2.2 Inverter Parameter Setting

Setting	Description
Time	Set the inverter time and date according to local time zone.
Slave Address	Set the inverter address when multiple inverters are installed.
Generation Calibration	Calibrate the inverter daily, monthly, annual and total yield.

6.4.2.3 Inverter Power Setting

Setting	Description
Output Power Setting	Set the inverter maximum AC output power.
PF Curve	Set the inverter power factor.
Power Limit	Set the power control slope, power rise control slope, power down control slope, EN 50549 power change gradient after fault trip restart, EN 50549 gradient limit for power-on change.

6.4.2.4 Load-shed mode setting

Basing on the different sensitivity of noise level to customer, customer can choose the loadshed mode of controlling fan to reduce noise.

Select "Inverter setting -> inverter special function setting -> loadshed fan control".

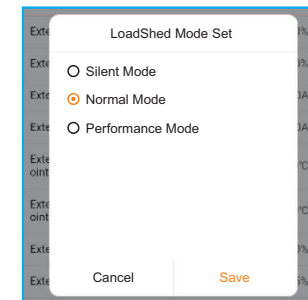

Noisy level(from max to min): Performance>normal>silent

6.4.3 Grid Parameter Setting

See Chapter 5.3 for details.

6.4.4 EPM Setting

Built-in EPM is for PV plant with only 1 inverter, while External EPM for multiple inverters.

6.4.4.1 Built-in EPM Setting

Select "Settings -> EPM Setting -> Built-in EPM Setting" to make the settings.
The Built-in EPM includes 2 functions related to the smart meter or smart sensor.



NOTE:

Function 1: Export Power Management Function

1. Inverters can work with a smart meter OR a smart sensor to dynamically limit the export power of the system.
2. Zero injection can be achieved.
3. Smart meter can be installed either on the grid side OR the load side.
Smart sensor can only be installed on the grid side.

Function 2: 24-Hour Load Monitoring Function

1. Only applicable if Solis monitoring system is used.
2. Inverters can work with a smart meter OR smart sensor to monitor the load consumption data for the whole day and the data will be displayed on the Solis monitoring system.
3. Smart meter or smart sensor can only be installed on the grid side.



NOTE:

Please refer to below instructions for different user scenarios.

Scenario 1. Only Function 1 is required

Using a Smart Meter:

- Step 1: Refer to Section 4.3.7 to connect the smart meter on the grid side or load side.
- Step 2: Select the corresponding meter model in the **Meter Selection**.
- Step 3: Choose **Meter in Grid Mode** or **Meter in Load Mode** in the **Built-in EPM mode selection** accordingly.
- Step 4: Configure the **System Export Power Limit Value** to set the allowed backflow power.
- Step 5: Configure the **Built-in EPM Failsafe Switch** to enable the failsafe function (If necessary).

Using a Smart Sensor:

- Step 1: Refer to Section 4.3.8 to connect the smart sensor on the grid side.
- Step 2: Select the **CT Sensor Mode** in the **Built-in EPM mode selection**.
- Step 3: Configure the **CT Ratio** and **CT Direction** at the "**Settings -> EPM Setting -> CT Setting**". (If necessary).
- Step 4: Configure the **System Export Power Limit Value** to set the allowed backflow power.
- Step 5: Configure the **Built-in EPM Failsafe Switch** to enable the failsafe function (If necessary).



NOTE:

Please refer to below instructions for different user scenarios.

Scenario 2. Only Function 2 is required

Using a Smart Meter:

- Step 1: Refer to Section 4.3.7 to connect the smart meter on the grid side or load side.
- Step 2: Select the corresponding meter model in the **Meter Selection**.
- Step 3: Choose **Meter 24-Hour Monitoring Mode** in the **Built-in EPM mode selection** accordingly.
- Step 4: Enable the **24-Hour Load Monitoring** function at "**Settings -> Inverter Setting -> Inverter Function Setting**".

Using a Smart Sensor:

- Step 1: Refer to Section 4.3.8 to connect the smart sensor on the grid side.
- Step 2: Select the **CT load Monitoring Mode** in the **Built-in EPM mode selection**.
- Step 3: Configure the **CT Ratio** and **CT Direction** at the "**Settings -> EPM Setting -> CT Setting**". (If necessary).
- Step 4: Enable the **24-Hour Load Monitoring** function at "**Settings -> Inverter Setting -> Inverter Function Setting**".



NOTE:

Please refer to below instructions for different user scenarios.

Scenario 3. Both Function 1 and 2 are required

Using a Smart Meter:

- Step 1: Refer to Section 4.3.7 to connect the smart meter on the grid side or load side.
- Step 2: Select the corresponding meter model in the **Meter Selection**.
- Step 3: Choose **Meter in Grid Mode** or **Meter in Load Mode** in the **Built-in EPM mode selection** accordingly.
- Step 4: Configure the **System Export Power Limit Value** to set the allowed backflow power.
- Step 5: Configure the **Built-in EPM Failsafe Switch** to enable the failsafe function (If necessary).
- Step 6: Enable the **24-Hour Load Monitoring** function at "**Settings -> Inverter Setting -> Inverter Function Setting**".

Using a Smart Sensor:

- Step 1: Refer to Section 4.3.8 to connect the smart sensor on the grid side.
- Step 2: Select the **CT Sensor Mode** in the **Built-in EPM mode selection**.
- Step 3: Configure the **CT Ratio** and **CT Direction** at the "**Settings -> EPM Setting -> CT Setting**". (If necessary).
- Step 4: Configure the **System Export Power Limit Value** to set the allowed backflow power.
- Step 5: Configure the **Built-in EPM Failsafe Switch** to enable the failsafe function (If necessary).
- Step 6: Enable the **24-Hour Load Monitoring** function at "**Settings -> Inverter Setting -> Inverter Function Setting**".

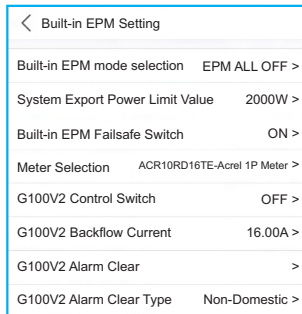

Setting	Description
Built-in EPM mode	6 built-in EPM mode is optional. Choose the appropriate mode needed.
System Export Power Limit Value	Set the permissible PV plant export power to the grid.
Built-in EPM Failsafe Switch	When G100 standard is used, this switch is enabled by default.
Meter Selection	Select the meter model according to the actual installation.
G100V2 Control Switch	When new G100 standard is used, enable this switch. Select the meter or CT mode according to the actual installation.
G100V2 Backflow Current	Set the backflow current of the PV plant to the grid. Only meaningful when G100V2 switch is on.
G100V2 Alarm Clear	Use this function to clear a fault status according to new G100 standard. Only meaningful when G100V2 switch is on.
G100V2 Alarm Clear Type	Select the Domestic or Non-domestic according to the actual installation. Only meaningful when G100V2 switch is on.

There are 6 modes for Built-in EPM.

- 1. EPM ALL OFF.** Built-in EPM function is disabled.
- 2. CT Sensor Mode.** Solis Smart Sensor is connected in the grid connection point (The **System Export Power Limit Value** setting is applicable, default value is 0W).
- 3. Meter in Grid Mode.** Solis Smart Meter is connected in the grid connection point (The **System Export Power Limit Value** setting is applicable, default value is 0W).
- 4. Meter in Load Mode.** Solis Smart Meter is connected in the load branch circuit (The **System Export Power Limit Value** setting is applicable, default value is 0W).
- 5. Meter 24-Hour Monitoring Mode.** Solis Smart Meter is connected in the grid connection point (used for 24h load monitoring only, the **System Export Power Limit Value** setting is not applicable).

6. CT load Monitoring Mode. Solis Smart Sensor is connected in the grid connection point (used for 24h load monitoring only, the **System Export Power Limit Value** setting is not applicable).

6.4.4.2 External EPM Setting

Select "**Settings -> EPM Setting -> External EPM Setting**".

External EPM Failsafe Swtich should be turned ON when external EPM device is used.

6.4.5 Inverter Work Mode Setting

Select "Settings -> Inverter Work Mode Setting".

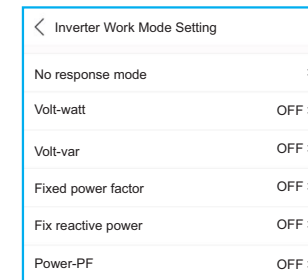

1. No response mode

Use this switch to close all response mode.

2. Volt-watt Mode

The volt-watt mode varies the active power output level of the inverter in response to the voltage at its grid-interactive port.

3. Volt-var Mode

The volt-var mode varies the reactive power absorbed or supplied by the inverter in response to the voltage at its grid-interactive port.

4. Fixed power factor Mode

The fixed power factor mode is for control of power factor over the range of inverter output.

5. Fixed reactive power Mode

The fixed reactive power mode is for control of reactive power over the range of inverter output.

6. Power-PF Mode

The Power-PF mode varies the active power output level of the inverter in response to its power factor.

7. Maintenance

Solis Three Phase Inverter does not require any regular maintenance. However, cleaning the dust on heat-sink will help the inverter to dissipate the heat and increase its life time. The dust can be removed with a soft brush.



CAUTION:

Do not touch the inverter's surface when it is operating. Some parts of the inverter may be hot and cause burns. Turn off the inverter (refer to Section 6.2) and wait for a cool-down period before any maintenance or cleaning operation.

The LCD and the LED status indicator lights can be cleaned with a damp cloth if they are too dirty to be read.



NOTE:

Never use any solvents, abrasives or corrosive materials to clean the inverter.

7.1 Night Time PID-Recovery Function

Solis Three phase Inverters integrates optional Night Time PID-Recovery module and it can recover the PID effect during night thus protect the PV system from degradation.

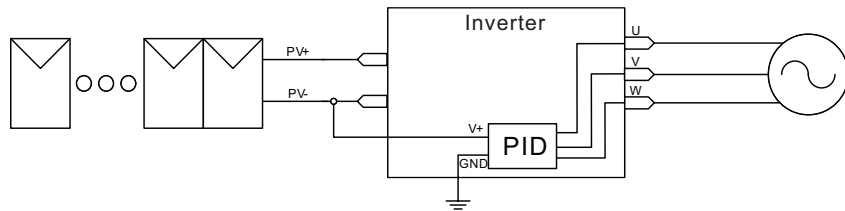

Figure 7.1

The Night Time PID-Recovery module repairs the PID effect of the PV model at night. When operating, the inverter LCD screen displays "PID-repairing" information, and the red light is on. The Night Time PID-Recovery function is always ON when AC is applied. If maintenance is required and turn off the AC switch can disable the Night Time PID-Recovery function.



WARNING :

The PID function is automatic. When the DC bus voltage is lower than 260Vdc, the PID module will start creating 650 Vdc between PV- and ground. No need any control or settings

7. Maintenance



NOTE:

If you need to maintain the inverter at night, please turn off the AC switch first, then turn off the DC switch, and wait 5 minutes before you do other operations.

7.2 Fan Maintenance

If the fan does not work properly, the inverter will not be cooled effectively, and it may affect the effective operation of the inverter .

Therefore, it is necessary to clean or replace a broken fan as follows:

1. Turn off the "Grid ON/OFF" switch on the inverter LCD.
2. Disconnect the AC power.
3. Turn the DC switch to "OFF" position.
4. Wait for 15 minutes at least.
5. Remove the 8 screws on the fan plate and pull out the fan assembly slowly.

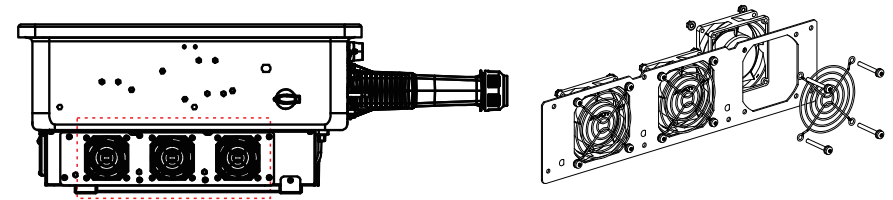

Figure 7.2

6. Disconnect the fan connector carefully and take out the fan.
7. Clean or replace the fan. Assemble the fan on the rack.
8. Connect the electrical wire and reinstall the fan assembly. Restart the inverter.

8. Troubleshooting

The inverter is designed in accordance with the most important international grid-tied standards and safety and electromagnetic compatibility requirements. Before delivering to the customer, the inverter has been subjected to several tests to ensure its optimal operation and reliability. In case of failure, the APP will display an alarm message. In this case, the inverter may stop feeding into the grid. The failure descriptions and their corresponding alarm messages are listed in Table 8.1:

Message Name	Information Description	Troubleshooting Suggestion
Grid Over Voltage 01 (1010 DATA:0001)	Over grid voltage	1. If it occurs by accident, it may be short-term abnormality of the power grid. The inverter will resume normal work after detecting the normal power grid, and no manual intervention is required.
Grid Over Voltage 02 (1010 DATA:0002)		
Grid Over Voltage 03 (1010 DATA:0003)		
Grid Over Voltage 04 (1010 DATA:0004)		
Grid Over Voltage 05 (1010 DATA:0005)		
Grid Under Voltage 01 (1011 DATA:0001)	Under grid voltage	1. If it occurs by accident, it may be short-term abnormality of the power grid. The inverter will resume normal work after detecting the normal power grid, and no manual intervention is required. 2. If it occurs frequently, check the grid voltage and check whether the grid frequency is in the inverter. Within the allowable range, if not, please contact customer service; if yes, please check if the AC side breaker and output cable are connected properly.
Grid Under Voltage 02 (1011 DATA:0002)		
Grid Over Frequency 01 (1012 DATA:0001)	Over grid frequency	3. If the grid voltage, grid frequency is within the allowable range of the inverter, and the AC side wiring confirmation It is true that this alarm still occurs frequently. After obtaining the consent of the local power operator, please contact customer service to modify the over-voltage and under-frequency protection points of the inverter power grid.
Grid Over Frequency 02 (1012 DATA:0001)		
Grid under Frequency 01 (1013 DATA:0001)	Under grid frequency	
Grid under Frequency 02 (1013 DATA:0002)		
NO-Grid (1015 DATA:0000)	No grid voltage	1. Verify that the grid is properly connected. 2. Check if the connected power grid is normal.
OV-G-I (1018 DATA:0000)	Over grid current	3. If the mains connection is normal, you need to contact our maintenance staff member.

8. Troubleshooting

Message Name	Information Description	Troubleshooting Suggestion
IGFOL-F (1019 DATA:0000)	Grid current tracking fail	1. Restart the inverter or contact our service personnel.
OV-DC (1020 DATA:0001)	Over DC voltage	1. Check whether the series configuration of the PV strings is excessive, resulting in the open circuit voltage of the PV array being higher than the maximum input voltage of the inverter. If so, reduce the number of strings and make the string open voltage fall within the inverter specification range.
OV-DC (1020 DATA:0002)		
OV-BUS (1021 DATA:0000)	Over DC bus voltage	1. Check if the input voltage exceeds the maximum input voltage of the inverter. 2. Restart the inverter. 3. If it is still not resolved, contact the factory's customer service.
UNB-BUS (1022 DATA:0000)	Under DC bus voltage	
DC Bus Under Voltage 01 (1023 DATA:0001)	DC bus undervoltage	1. Check if the input voltage is too low. 2. Restart the inverter. 3. If it has not been eliminated, contact the factory's customer service.
DC Bus Under Voltage 02 (1023 DATA:0002)	Abnormal detection of DC bus voltage	
OV-DCA-I (1025 DATA:0000)	DC 1 average overcurrent	1. Check whether the MPPT of the A-way is reversed polarity. 2. Restart the inverter. 3. If it has not been eliminated, contact the factory's customer service.
OV-DCB-I (1026 DATA:0000)	DC 2 average overcurrent	1. Check whether the MPPT of the B-way is reversed polarity. 2. Restart the inverter. 3. If it has not been eliminated, contact the factory's customer service.
DC-INTF. (1027 DATA:0000)	DC hardware overcurrent	1. Check whether the DC connection is broken or damaged. 2. Restart the inverter. 3. If it has not been removed, contact the factory's customer service.
Reverse-DC (1028 DATA:0000)	Reverse DC polarity	1. Check if the DC line is reversed. 2. Restart the inverter. 3. If it is still not excluded, please contact the factory customer service.

8. Troubleshooting

Message Name	Information Description	Troubleshooting Suggestion
GRID-INTF. (1030 DATA:0000)	AC hardware overcurrent	<ol style="list-style-type: none"> 1. Check whether the AC connection is virtual. 2. Restart the inverter. 3. If it has not been eliminated, contact the factory's customer service.
INI-FAULT (1031 DATA:0000)	Initialization system fault	<ol style="list-style-type: none"> 1. Restart the inverter. 2. If it is still not resolved, contact the factory's customer service.
OV-TEM (1032 DATA:0000)	Over Temperature	<ol style="list-style-type: none"> 1. Check whether the inverter installation position meets the requirements of the user manual. 2. Try to reduce the ambient temperature. 3. Restart the inverter after fifteen minutes. 4. If the error persists, please contact the factory's customer service.
PV Isolation Protection 01 (1033 DATA:0001)	DC bus undervoltage	<ol style="list-style-type: none"> 1. Check whether the PV strings have insulation problems. 2. Check whether the PV cable is damaged.
PV Isolation Protection 02 (1033 DATA:0002)	PV negative ground fault	
Leakage Current Protection 01 (1034 DATA:0001)	Leakage current protection	<ol style="list-style-type: none"> 1. Connect each string component individually to determine if it is caused by a component problem. If there is no error when inserting one of the string components, it can be determined that it is a string problem. Check whether the string in question is broken or not. 2. If this error is only caused by a rainy day or a certain time of the morning, it is because the aging of the module causes the leakage current to be too large. When the weather is fine or the air humidity is reduced, the error will be cleared automatically. Can be resolved through remote upgrade software.
Leakage Current Protection 02 (1034 DATA:0002)		
Leakage Current Protection 03 (1034 DATA:0003)		
Leakage Current Protection 04 (1034 DATA:0004)		
lLeak-Check (1039 DATA:0000)	Leakage current sensor failure	<ol style="list-style-type: none"> 1. Upgrade software to the latest version. 2. If the fault persists, please contact the factory's customer service.
UN-TEM (103A DATA:0000)	Under Temperature	<ol style="list-style-type: none"> 1. Check if the ambient temperature is too low and restart the inverter. If it has not been eliminated, contact the factory's customer service.

8. Troubleshooting

Message Name	Information Description	Troubleshooting Suggestion
Relay-FAULT (1035 DATA:0000)	Relay check fail	<ol style="list-style-type: none"> 1. Restart the inverter 2. If it is still not resolved, contact the factory's customer service.
DSP-B-Com-Fau (1036 DATA:0000)	Comm. failure between main and slave DSP	
DCInj-FAULT (1037 DATA:0000)	High DC injection current	
12Power-FAULT (1038 DATA:0000)	12V power supply fault	
AFCI-Check (1040 DATA:0000)	AFCI module self-detect fault	<ol style="list-style-type: none"> 1. Restart the inverter. 2. If it is still not resolved, contact the factory's customer service.
ARC-FAULT (1041 DATA:0000)	Detect arc in DC circuit	<ol style="list-style-type: none"> 1. Check for arc in the inverter connection and restart the inverter.
GRID-INTF02 (1046 DATA:0000)	Power grid disturbance 02	<ol style="list-style-type: none"> 1. Check if the grid side is not healthy. 2. Restart the inverter. If it is still not removed, contact the factory's customer service.
IG-AD (1047 DATA:0000)	Grid current sampling fail	<ol style="list-style-type: none"> 1. Restart the inverter 2. If it is still not resolved, contact the factory's customer service.
IGBT-OV-I (1048 DATA:0000)	Over IGBT current	
State 2 excursion (2043H)	G100 State 2 excursion	The alarm appears when the current flow exceeds "G100V2 Backflow Current" under scenarios stipulated by G100 standard. As required by G100, "State 2 excursion" alarm should be manually reset. Please select the "Settings -> EPM Setting -> Built-in EPM Setting->G100V2 Alarm Clear" to reset.
Fail Safe 2010H	Meter Communication Fail	<ol style="list-style-type: none"> 1. Check the meter communication and restart the inverter. 2. If it is still not resolved, contact the factory's customer service.
MET_SEL_FAIL 2019H	Meter type select fail	Please select the correct smart meter type in inverter setting based on the smart meter actually connected to the inverter.

8. Troubleshooting

Message Name	Information Description	Troubleshooting Suggestion
CT Fault 201AH	CT Fault	The alarm occurs when the CT connected to the inverter or the CT connected to the smart meter loses connection. 1. When the alarm occurs with the "G100V2 Control Switch" on, please check and repair the CT wiring first, then select "Settings -> EPM Setting -> Built-in EPM Setting-> G100V2 Alarm Clear" to reset the alarm. 2. When the alarm occurs with the "G100V2 Control Switch" off, please check and repair the CT wiring and restart the inverter. 3. If it is still not resolved, contact the factory's customer service.
DRM_LINK_FAIL 2018H	DRM link fail	Please check if your DRM control device/ logic interface or its wiring is normal. If there is actually no DRM control device/ logic interface connected, please disable the DRM function in inverter settings.
DRM_CTL_Off 201BH	DRM control inverter to stop	Please check if the DRM function is enabled. This alarm indicates the DRM function controls the inverter to stop. If this is not expected, please disable the DRM function.
AFCI-Comm-Fail 2041H	AFCI communication fail	1. Restart the inverter . 2. If it is still not resolved, contact the factory's customer service.
AFCI-CTModule-Fail 2042H	AFCI CT module fail	

Table 8.1 Fault message and description



NOTE:

If the inverter displays any alarm message as listed in Table 8.1; please turn off the inverter and wait for 5 minutes before restarting it .
If the failure persists, please contact your local distributor or the service center.

1. Serial number of Solis Inverter;
2. The distributor/dealer of Solis Inverter (if available);
3. Installation date.
4. The description of problem (i.e. the alarm message displayed on the LCD and the status of the LED status indicator lights. Other readings obtained from the Information submenu will also be helpful.);
5. The PV array configuration (e.g. number of panels, capacity of panels, number of strings , etc.);
6. Your contact details.

9. Specifications

Model	S6-GC3P37.5K04-NV-ND
Max. DC input voltage (Volts)	1100
Rated DC voltage (Volts)	600
Start-up voltage (Volts)	180
MPPT voltage range (Volts)	180...1000
Max. input current (Amps)	4*42
Max short circuit input current (Amps)	4*52.5
MPPT number/Max input strings number	4/8
Classification	AFCI Type: F-I-AFPE-1-4-2
No.of monitored strings per input port	1
No.of input ports per channel	4
No.of monitored channels	2
Rated channel current (Amps)	84
Maximum current per input port (Amps)	21
Rated interruption current (Amps)	21
Rated output power (Watts)	37500
Max. output power (Watts)	37500
Max. apparent output power (VA)	37500
Rated grid voltage (Volts)	3/N/PE, 220/380
Rated grid output current (Amps)	57.0
Max. output current (Amps)	57.0
Power Factor (at rated output power)	0.8leading~0.8lagging
THDi (at rated output power)	<3%
Rated grid frequency (Hertz)	50/60
Max. efficiency	98.6%
EU efficiency	98.1%
Dimensions (W*H*D)	508*612*288mm
Weight	34.9kg
Topology	Transformerless
Self consumption (night)	< 1W
Operating ambient temperature range	-25°C...+60°C
Relative humidity	0~100%
Ingress protection	IP66
Noise emission {Typical}	≤55 dB (A)
Cooling concept	Intelligent redundant cooling
Max.operation altitude	4000m
Max. inverter backfeed current to the array (Amps)	0
Protective class	I
Overvoltage category	DC II, AC II
GRID TYPE	TT, TN

9. Specifications

Model	S6-GC3P37.5K04-NV-ND
Grid connection standard	portaria N140&515
Safety/EMC standard	IEC 62109-1, IEC 62109-2
DC connection	MC4 connector
AC connection	OT Terminal
Display	LED + APP
Communication connections	RS485, Optional: Wi-Fi, GPRS

9. Specifications

Model	S6-GC3P40K04-NV-ND
Max. DC input voltage (Volts)	1100
Rated DC voltage (Volts)	600
Start-up voltage (Volts)	180
MPPT voltage range (Volts)	180...1000
Max. input current (Amps)	4*42
Max short circuit input current (Amps)	4*52.5
MPPT number/Max input strings number	4/8
Classification	AFCI Type: F-I-AFPE-1-4-2
No.of monitored strings per input port	1
No.of input ports per channel	4
No.of monitored channels	2
Rated channel current (Amps)	84
Maximum current per input port (Amps)	21
Rated interruption current (Amps)	21
Rated output power (Watts)	40000
Max. output power (Watts)	40000
Max. apparent output power (VA)	40000
Rated grid voltage (Volts)	3/N/PE, 220/380, 230/400
Rated grid output current (Amps)	60.8/57.7
Max. output current (Amps)	60.8/57.7
Power Factor (at rated output power)	0.8leading~0.8lagging
THDi (at rated output power)	<3%
Rated grid frequency (Hertz)	50/60
Max. efficiency	98.6%
EU efficiency	98.1%
Dimensions (W*H*D)	508*612*288mm
Weight	34.9kg
Topology	Transformerless
Self consumption (night)	< 1W
Operating ambient temperature range	-25°C...+60°C
Relative humidity	0~100%
Ingress protection	IP66
Noise emission {Typical}	≤55 dB (A)
Cooling concept	Intelligent redundant cooling
Max.operation altitude	4000m
Max. inverter backfeed current to the array (Amps)	0
Protective class	I
Overvoltage category	DC II, AC II
GRID TYPE	TT, TN

9. Specifications

Model	S6-GC3P40K04-NV-ND
Grid connection standard	G98 or G99, VDE-AR-N 4105 / VDE V 0124, EN 50549-1, VDE 0126 / UTE C 15 / VFR:2019, RD 1699 / RD 244 / UNE 206006 / UNE 206007-1, CEI 0-21, C10/11, NRS 097-2-1, TOR, EIFS 2018.2, IEC 62116, IEC 61727, IEC60068, IEC 61683, EN 50530
Safety/EMC standard	IEC/EN 62109-1/-2, IEC/EN 61000-6-1/-2/-3/-4
DC connection	MC4 connector
AC connection	OT Terminal
Display	LED + APP
Communication connections	RS485, Optional: Wi-Fi, GPRS

9. Specifications

Model	S6-GC3P50K04-NV-ND
Max. DC input voltage (Volts)	1100
Rated DC voltage (Volts)	600
Start-up voltage (Volts)	180
MPPT voltage range (Volts)	180...1000
Max. input current (Amps)	4*42
Max short circuit input current (Amps)	4*52.5
MPPT number/Max input strings number	4/8
Classification	AFCI Type: F-I-AFPE-1-4-2
No. of monitored strings per input port	1
No. of input ports per channel	4
No. of monitored channels	2
Rated channel current (Amps)	84
Maximum current per input port (Amps)	21
Rated interruption current (Amps)	21
Rated output power (Watts)	50000
Max. output power (Watts)	50000
Max. apparent output power (VA)	50000
Rated grid voltage (Volts)	3/N/PE, 220/380, 230/400
Rated grid output current (Amps)	76.0/72.2
Max. output current (Amps)	76.0/72.2
Power Factor (at rated output power)	0.8leading~0.8lagging
THDi (at rated output power)	<3%
Rated grid frequency (Hertz)	50/60
Max. efficiency	98.6%
EU efficiency	98.1%
Dimensions (W*H*D)	508*612*288mm
Weight	35.8kg
Topology	Transformerless
Self consumption (night)	< 1W
Operating ambient temperature range	-25°C...+60°C
Relative humidity	0~100%
Ingress protection	IP66
Noise emission {Typical}	≤55 dB (A)
Cooling concept	Intelligent redundant cooling
Max. operation altitude	4000m
Max. inverter backfeed current to the array (Amps)	0
Protective class	I
Overvoltage category	DC II, AC II
GRID TYPE	TT, TN

9. Specifications

Model	S6-GC3P50K04-NV-ND
Grid connection standard	G98 or G99, VDE-AR-N 4105 / VDE V 0124, EN 50549-1, VDE 0126 / UTE C 15 / VFR:2019, RD 1699 / RD 244 / UNE 206006 / UNE 206007-1, CEI 0-21, C10/11, NRS 097-2-1, TOR, EIFS 2018.2, IEC 62116, IEC 61727, IEC60068, IEC 61683, EN 50530
Safety/EMC standard	IEC/EN 62109-1/-2, IEC/EN 61000-6-1/-2/-3/-4
DC connection	MC4 connector
AC connection	OT Terminal
Display	LED + APP
Communication connections	RS485, Optional: Wi-Fi, GPRS

9. Specifications

Model	S6-GC3P60K05-NV-ND
Max. DC input voltage (Volts)	1100
Rated DC voltage (Volts)	600
Start-up voltage (Volts)	180
MPPT voltage range (Volts)	180...1000
Max. input current (Amps)	5*42
Max short circuit input current (Amps)	5*52.5
MPPT number/Max input strings number	5/10
Classification	AFCI Type: F-I-AFPE-1-4/4/2-3
No. of monitored strings per input port	1
No. of input ports per channel	4/4/2
No. of monitored channels	3
Rated channel current (Amps)	84/84/42
Maximum current per input port (Amps)	21
Rated interruption current (Amps)	21
Rated output power (Watts)	60000
Max. output power (Watts)	60000
Max. apparent output power (VA)	60000
Rated grid voltage (Volts)	3/N/PE, 220/380, 230/400
Rated grid output current (Amps)	91.2/86.6
Max. output current (Amps)	91.2/86.6
Power Factor (at rated output power)	0.8leading~0.8lagging
THDi (at rated output power)	<3%
Rated grid frequency (Hertz)	50/60
Max. efficiency	98.6%
EU efficiency	98.1%
Dimensions (W*H*D)	508*612*288mm
Weight	38.6kg
Topology	Transformerless
Self consumption (night)	< 1W
Operating ambient temperature range	-25°C...+60°C
Relative humidity	0~100%
Ingress protection	IP66
Noise emission {Typical}	≤55 dB (A)
Cooling concept	Intelligent redundant cooling
Max. operation altitude	4000m
Max. inverter backfeed current to the array (Amps)	0
Protective class	I
Overvoltage category	DC II, AC II
GRID TYPE	TT, TN

9. Specifications

Model	S6-GC3P60K05-NV-ND
Grid connection standard	G98 or G99, VDE-AR-N 4105 / VDE V 0124, EN 50549-1, VDE 0126 / UTE C 15 / VFR:2019, RD 1699 / RD 244 / UNE 206006 / UNE 206007-1, CEI 0-21, C10/11, NRS 097-2-1, TOR, EIFS 2018.2, IEC 62116, IEC 61727, IEC60068, IEC 61683, EN 50530
Safety/EMC standard	IEC/EN 62109-1/-2, IEC/EN 61000-6-1/-2/-3/-4
DC connection	MC4 connector
AC connection	OT Terminal
Display	LED + APP
Communication connections	RS485, Optional: Wi-Fi, GPRS

9. Specifications

Model	S6-GC3P50K04-HV-ND
Max. DC input voltage (Volts)	1100
Rated DC voltage (Volts)	720
Start-up voltage (Volts)	180
MPPT voltage range (Volts)	180...1000
Max. input current (Amps)	4*42
Max short circuit input current (Amps)	4*52.5
MPPT number/Max input strings number	4/8
Classification	AFCI Type: F-I-AFPE-1-4-2
No. of monitored strings per input port	1
No. of input ports per channel	4
No. of monitored channels	2
Rated channel current (Amps)	84
Maximum current per input port (Amps)	21
Rated interruption current (Amps)	21
Rated output power (Watts)	50000
Max. output power (Watts)	50000
Max. apparent output power (VA)	50000
Rated grid voltage (Volts)	3/PE, 480
Rated grid output current (Amps)	60.1
Max. output current (Amps)	60.1
Power Factor (at rated output power)	0.8leading~0.8lagging
THDi (at rated output power)	<3%
Rated grid frequency (Hertz)	50/60
Max. efficiency	98.7%
EU efficiency	98.1%
Dimensions (W*H*D)	508*612*288mm
Weight	34.4kg
Topology	Transformerless
Self consumption (night)	< 1W
Operating ambient temperature range	-25°C...+60°C
Relative humidity	0~100%
Ingress protection	IP66
Noise emission {Typical}	≤55 dB (A)
Cooling concept	Intelligent redundant cooling
Max. operation altitude	4000m
Max. inverter backfeed current to the array (Amps)	0
Protective class	I
Overvoltage category	DC II, AC II
GRID TYPE	IT

9. Specifications

Model	S6-GC3P50K04-HV-ND
Grid connection standard	G98 or G99, VDE-AR-N 4105 / VDE V 0124, EN 50549-1, VDE 0126 / UTE C 15 / VFR:2019, RD 1699 / RD 244 / UNE 206006 / UNE 206007-1, CEI 0-21, C10/11, NRS 097-2-1, TOR, EIFS 2018.2, IEC 62116, IEC 61727, IEC60068, IEC 61683, EN 50530
Safety/EMC standard	IEC/EN 62109-1/-2, IEC/EN 61000-6-1/-2/-3/-4
DC connection	MC4 connector
AC connection	OT Terminal
Display	LED + APP
Communication connections	RS485, Optional: Wi-Fi, GPRS

9. Specifications

Model	S6-GC3P60K05-HV-ND
Max. DC input voltage (Volts)	1100
Rated DC voltage (Volts)	720
Start-up voltage (Volts)	180
MPPT voltage range (Volts)	180...1000
Max. input current (Amps)	5*42
Max short circuit input current (Amps)	5*52.5
MPPT number/Max input strings number	5/10
Classification	AFCI Type: F-I-AFPE-1-4/4/2-3
No. of monitored strings per input port	1
No. of input ports per channel	4/4/2
No. of monitored channels	3
Rated channel current (Amps)	84/84/42
Maximum current per input port (Amps)	21
Rated interruption current (Amps)	21
Rated output power (Watts)	60000
Max. output power (Watts)	60000
Max. apparent output power (VA)	60000
Rated grid voltage (Volts)	3/PE, 480
Rated grid output current (Amps)	72.2
Max. output current (Amps)	72.2
Power Factor (at rated output power)	0.8leading~0.8lagging
THDi (at rated output power)	<3%
Rated grid frequency (Hertz)	50/60
Max. efficiency	98.7%
EU efficiency	98.1%
Dimensions (W*H*D)	508*612*288mm
Weight	37.4kg
Topology	Transformerless
Self consumption (night)	< 1W
Operating ambient temperature range	-25°C...+60°C
Relative humidity	0~100%
Ingress protection	IP66
Noise emission {Typical}	≤55 dB (A)
Cooling concept	Intelligent redundant cooling
Max. operation altitude	4000m
Max. inverter backfeed current to the array (Amps)	0
Protective class	I
Overvoltage category	DC II, AC II
GRID TYPE	IT

9. Specifications

Model	S6-GC3P60K05-HV-ND
Grid connection standard	G98 or G99, VDE-AR-N 4105 / VDE V 0124, EN 50549-1, VDE 0126 / UTE C 15 / VFR:2019, RD 1699 / RD 244 / UNE 206006 / UNE 206007-1, CEI 0-21, C10/11, NRS 097-2-1, TOR, EIFS 2018.2, IEC 62116, IEC 61727, IEC60068, IEC 61683, EN 50530
Safety/EMC standard	IEC/EN 62109-1/-2, IEC/EN 61000-6-1/-2/-3/-4
DC connection	MC4 connector
AC connection	OT Terminal
Display	LED + APP
Communication connections	RS485, Optional: Wi-Fi, GPRS

9. Specifications

Model	S6-GC3P23K03-LV-ND
Max. DC input voltage (Volts)	1100
Rated DC voltage (Volts)	400
Start-up voltage (Volts)	180
MPPT voltage range (Volts)	180...1000
Max. input current (Amps)	3*42
Max short circuit input current (Amps)	3*52.5
MPPT number/Max input strings number	3/6
Classification	AFCI Type: F-I-AFPE-1-4/2-2
No. of monitored strings per input port	1
No. of input ports per channel	4/2
No. of monitored channels	2
Rated channel current (Amps)	84/42
Maximum current per input port (Amps)	21
Rated interruption current (Amps)	21
Rated output power (Watts)	23000
Max. output power (Watts)	23000
Max. apparent output power (VA)	23000
Rated grid voltage (Volts)	3/PE, 220/230
Rated grid output current (Amps)	60.4/57.7
Max. output current (Amps)	60.4/57.7
Power Factor (at rated output power)	0.8leading~0.8lagging
THDi (at rated output power)	<3%
Rated grid frequency (Hertz)	50/60
Max. efficiency	97.8%
EU efficiency	97.3%
Dimensions (W*H*D)	508*612*288mm
Weight	35.6kg
Topology	Transformerless
Self consumption (night)	< 1W
Operating ambient temperature range	-25°C...+60°C
Relative humidity	0~100%
Ingress protection	IP66
Noise emission {Typical}	≤55 dB (A)
Cooling concept	Intelligent redundant cooling
Max. operation altitude	4000m
Max. inverter backfeed current to the array (Amps)	0
Protective class	I
Overvoltage category	DC II, AC II
GRID TYPE	IT

9. Specifications

Model	S6-GC3P23K03-LV-ND
Grid connection standard	G98 or G99, VDE-AR-N 4105 / VDE V 0124, EN 50549-1, VDE 0126 / UTE C 15 / VFR:2019, RD 1699 / RD 244 / UNE 206006 / UNE 206007-1, CEI 0-21, C10/11, NRS 097-2-1, TOR, EIFS 2018.2, IEC 62116, IEC 61727, IEC60068, IEC 61683, EN 50530
Safety/EMC standard	IEC/EN 62109-1/-2, IEC/EN 61000-6-1/-2/-3/-4
DC connection	MC4 connector
AC connection	OT Terminal
Display	LED + APP
Communication connections	RS485, Optional: Wi-Fi, GPRS

9. Specifications

Model	S6-GC3P25K04-LV-ND
Max. DC input voltage (Volts)	1100
Rated DC voltage (Volts)	400
Start-up voltage (Volts)	180
MPPT voltage range (Volts)	180...1000
Max. input current (Amps)	4*42
Max short circuit input current (Amps)	4*52.5
MPPT number/Max input strings number	4/8
Classification	AFCI Type: F-I-AFPE-1-4-2
No. of monitored strings per input port	1
No. of input ports per channel	4
No. of monitored channels	2
Rated channel current (Amps)	84
Maximum current per input port (Amps)	21
Rated interruption current (Amps)	21
Rated output power (Watts)	25000
Max. output power (Watts)	25000
Max. apparent output power (VA)	25000
Rated grid voltage (Volts)	3/PE, 220/230
Rated grid output current (Amps)	65.6/62.8
Max. output current (Amps)	65.6/62.8
Power Factor (at rated output power)	0.8leading~0.8lagging
THDi (at rated output power)	<3%
Rated grid frequency (Hertz)	50/60
Max. efficiency	97.8%
EU efficiency	97.3%
Dimensions (W*H*D)	508*612*288mm
Weight	35.9kg
Topology	Transformerless
Self consumption (night)	< 1W
Operating ambient temperature range	-25°C...+60°C
Relative humidity	0~100%
Ingress protection	IP66
Noise emission {Typical}	≤55 dB (A)
Cooling concept	Intelligent redundant cooling
Max. operation altitude	4000m
Max. inverter backfeed current to the array (Amps)	0
Protective class	I
Overvoltage category	DC II, AC II
GRID TYPE	IT

9. Specifications

Model	S6-GC3P25K04-LV-ND
Grid connection standard	G98 or G99, VDE-AR-N 4105 / VDE V 0124, EN 50549-1, VDE 0126 / UTE C 15 / VFR:2019, RD 1699 / RD 244 / UNE 206006 / UNE 206007-1, CEI 0-21, C10/11, NRS 097-2-1, TOR, EIFS 2018.2, IEC 62116, IEC 61727, IEC60068, IEC 61683, EN 50530
Safety/EMC standard	IEC/EN 62109-1/-2, IEC/EN 61000-6-1/-2/-3/-4
DC connection	MC4 connector
AC connection	OT Terminal
Display	LED + APP
Communication connections	RS485, Optional: Wi-Fi, GPRS

9. Specifications

Model	S6-GC3P30K04-LV-ND
Max. DC input voltage (Volts)	1100
Rated DC voltage (Volts)	400
Start-up voltage (Volts)	180
MPPT voltage range (Volts)	180...1000
Max. input current (Amps)	4*42
Max short circuit input current (Amps)	4*52.5
MPPT number/Max input strings number	4/8
Classification	AFCI Type: F-I-AFPE-1-4-2
No. of monitored strings per input port	1
No. of input ports per channel	4
No. of monitored channels	2
Rated channel current (Amps)	84
Maximum current per input port (Amps)	21
Rated interruption current (Amps)	21
Rated output power (Watts)	30000
Max. output power (Watts)	30000
Max. apparent output power (VA)	30000
Rated grid voltage (Volts)	3/PE, 220/230
Rated grid output current (Amps)	78.7/75.3
Max. output current (Amps)	78.7/75.3
Power Factor (at rated output power)	0.8leading~0.8lagging
THDi (at rated output power)	<3%
Rated grid frequency (Hertz)	50/60
Max. efficiency	97.8%
EU efficiency	97.3%
Dimensions (W*H*D)	508*612*288mm
Weight	35.9kg
Topology	Transformerless
Self consumption (night)	< 1W
Operating ambient temperature range	-25°C...+60°C
Relative humidity	0~100%
Ingress protection	IP66
Noise emission {Typical}	≤55 dB (A)
Cooling concept	Intelligent redundant cooling
Max. operation altitude	4000m
Max. inverter backfeed current to the array (Amps)	0
Protective class	I
Overvoltage category	DC II, AC II
GRID TYPE	IT

9. Specifications

Model	S6-GC3P30K04-LV-ND
Grid connection standard	G98 or G99, VDE-AR-N 4105 / VDE V 0124, EN 50549-1, VDE 0126 / UTE C 15 / VFR:2019, RD 1699 / RD 244 / UNE 206006 / UNE 206007-1, CEI 0-21, C10/11, NRS 097-2-1, TOR, EIFS 2018.2, IEC 62116, IEC 61727, IEC60068, IEC 61683, EN 50530
Safety/EMC standard	IEC/EN 62109-1/-2, IEC/EN 61000-6-1/-2/-3/-4
DC connection	MC4 connector
AC connection	OT Terminal
Display	LED + APP
Communication connections	RS485, Optional: Wi-Fi, GPRS

9. Specifications

Model	S6-GC3P36K04-LV-ND
Max. DC input voltage (Volts)	1100
Rated DC voltage (Volts)	400
Start-up voltage (Volts)	180
MPPT voltage range (Volts)	180...1000
Max. input current (Amps)	4*42
Max short circuit input current (Amps)	4*52.5
MPPT number/Max input strings number	4/8
Classification	AFCI Type: F-I-AFPE-1-4-2
No. of monitored strings per input port	1
No. of input ports per channel	4
No. of monitored channels	2
Rated channel current (Amps)	84
Maximum current per input port (Amps)	21
Rated interruption current (Amps)	21
Rated output power (Watts)	36000
Max. output power (Watts)	36000
Max. apparent output power (VA)	36000
Rated grid voltage (Volts)	3/PE, 220/230
Rated grid output current (Amps)	94.5/90.4
Max. output current (Amps)	94.5/90.4
Power Factor (at rated output power)	0.8leading~0.8lagging
THDi (at rated output power)	<3%
Rated grid frequency (Hertz)	50/60
Max. efficiency	97.8%
EU efficiency	97.3%
Dimensions (W*H*D)	508*612*288mm
Weight	36.2kg
Topology	Transformerless
Self consumption (night)	< 1W
Operating ambient temperature range	-25°C...+60°C
Relative humidity	0~100%
Ingress protection	IP66
Noise emission {Typical}	≤55 dB (A)
Cooling concept	Intelligent redundant cooling
Max. operation altitude	4000m
Max. inverter backfeed current to the array (Amps)	0
Protective class	I
Overvoltage category	DC II, AC II
GRID TYPE	IT

9. Specifications

Model	S6-GC3P36K04-LV-ND
Grid connection standard	G98 or G99, VDE-AR-N 4105 / VDE V 0124, EN 50549-1, VDE 0126 / UTE C 15 / VFR:2019, RD 1699 / RD 244 / UNE 206006 / UNE 206007-1, CEI 0-21, C10/11, NRS 097-2-1, TOR, EIFS 2018.2, IEC 62116, IEC 61727, IEC60068, IEC 61683, EN 50530
Safety/EMC standard	IEC/EN 62109-1/-2, IEC/EN 61000-6-1/-2/-3/-4
DC connection	MC4 connector
AC connection	OT Terminal
Display	LED + APP
Communication connections	RS485, Optional: Wi-Fi, GPRS

9. Specifications

Model	S6-GC3P37.5K04-LV-ND
Max. DC input voltage (Volts)	1100
Rated DC voltage (Volts)	400
Start-up voltage (Volts)	180
MPPT voltage range (Volts)	180...1000
Max. input current (Amps)	4*42
Max short circuit input current (Amps)	4*52.5
MPPT number/Max input strings number	4/8
Classification	AFCI Type: F-I-AFPE-1-4-2
No. of monitored strings per input port	1
No. of input ports per channel	4
No. of monitored channels	2
Rated channel current (Amps)	84
Maximum current per input port (Amps)	21
Rated interruption current (Amps)	21
Rated output power (Watts)	37500
Max. output power (Watts)	37500
Max. apparent output power (VA)	37500
Rated grid voltage (Volts)	3/PE, 220
Rated grid output current (Amps)	98.4
Max. output current (Amps)	98.4
Power Factor (at rated output power)	0.8leading~0.8lagging
THDi (at rated output power)	<3%
Rated grid frequency (Hertz)	50/60
Max. efficiency	97.8%
EU efficiency	97.3%
Dimensions (W*H*D)	508*612*288mm
Weight	36.6kg
Topology	Transformerless
Self consumption (night)	< 1W
Operating ambient temperature range	-25°C...+60°C
Relative humidity	0~100%
Ingress protection	IP66
Noise emission {Typical}	≤55 dB (A)
Cooling concept	Intelligent redundant cooling
Max. operation altitude	4000m
Max. inverter backfeed current to the array (Amps)	0
Protective class	I
Overvoltage category	DC II, AC II
GRID TYPE	IT

9. Specifications

Model	S6-GC3P37.5K04-LV-ND
Grid connection standard	portaria N140&515
Safety/EMC standard	IEC 62109-1, IEC 62109-2
DC connection	MC4 connector
AC connection	OT Terminal
Display	LED + APP
Communication connections	RS485, Optional: Wi-Fi, GPRS