



EPISODE 68

Optimizing Power Supply: Running Inverters in Parallel with Generators for C&I PV system

Bankable. Reliable. Local.

Optimizing Power Supply: Running Inverters in Parallel with Generators for C&I PV system

In areas where grid power is unavailable or unreliable, diesel generators are commonly used to provide electricity. However, relying solely on diesel generators can be expensive and inefficient. Integrating photovoltaic (PV) inverters in parallel with generators offers a cost-effective and sustainable energy solution, reducing fuel consumption and ensuring a stable power supply; Solis provides solutions for C&I PV projects running in parallel with diesel generators, covering applications with tens of kW to thousands of kW capacity.

>> Why Parallel Operation Matters

Running inverters in parallel with generators provides several advantages, including:

- **Fuel Cost Savings:** By allowing solar energy to supplement generator power, fuel consumption is reduced, leading to lower operational costs.
- **Increased Energy Efficiency:** Inverters manage power distribution efficiently, ensuring optimal use of renewable energy while minimizing generator wear and tear.
- **Enhanced Reliability:** A hybrid system provides consistent power, even when solar energy generation fluctuates due to weather conditions.
- **Seamless Power Supply:** Inverter-generator synchronization ensures a smooth transition between power sources without interruptions.

>> Key Scenarios for Inverter-Generator Parallel Operation

Scenario 1: No Grid Available

In off-grid locations, inverters can be configured to operate in parallel with a generator, ensuring stable power supply. In this setup:

- Multiple inverters are connected using RS485 cables in a daisy-chain format.
- One inverter is set as the master, while the others act as slaves.
- The master inverter controls power output, ensuring that no excess energy is injected into the generator.

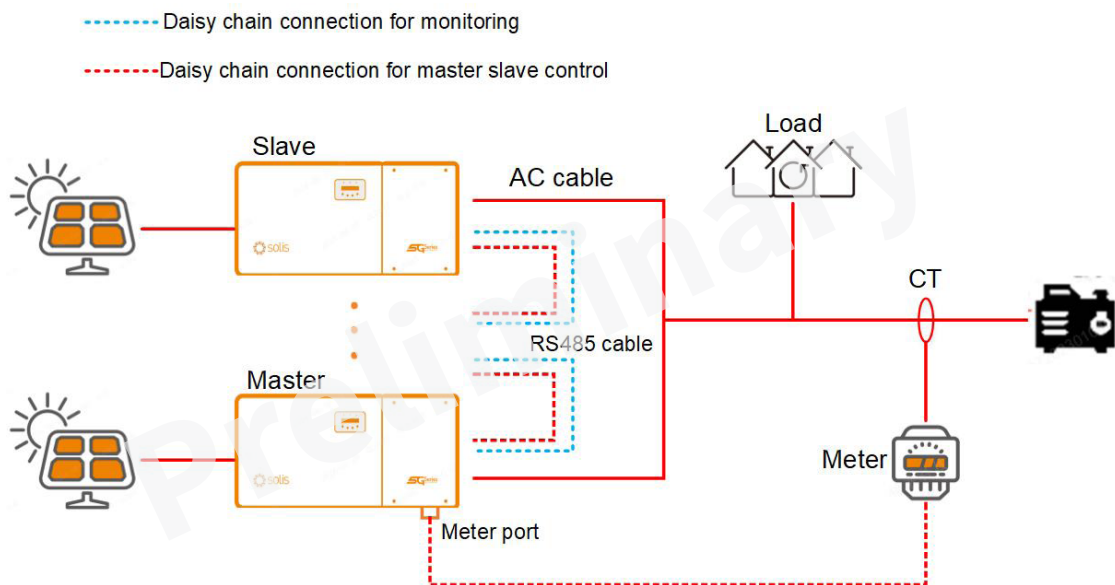

Scenario 2: Grid Availability with an Automatic Transfer Switch (ATS)

When grid power is present, an ATS is installed to switch between the grid and generator as needed. In this scenario:

- A rectifier (220VAC/5VDC) signals the inverter when the generator starts.
- The master inverter coordinates all inverters, ensuring safe power sharing between PV and the generator.

>> Meter Connection

To ensure accurate power monitoring, the energy meter must be properly connected:

- The meter model used should be Arc ADL400.
- The meter must be connected to the master inverter for accurate system measurement and control.

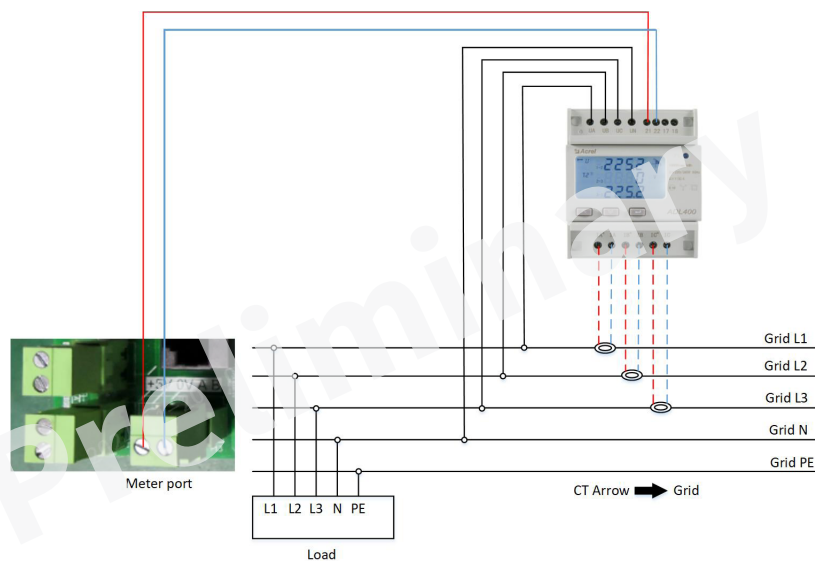

Inverter Parallel Connection for Monitoring

- All inverters must be interconnected in a daisy-chain format using RS485 communication cables.
- This connection enables real-time data exchange between inverters for system-wide monitoring.

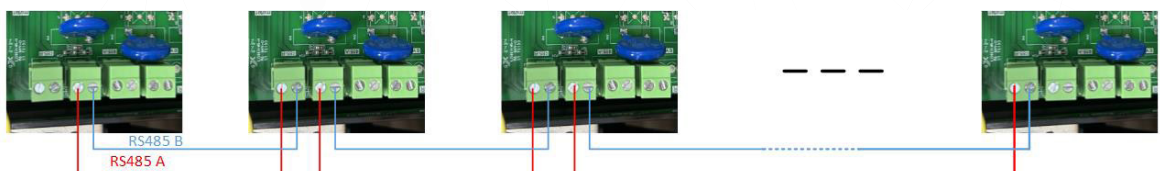

Inverter Parallel Connection for Master-Slave Control

- A dedicated RS485 daisy-chain connection is required for master-slave communication.
- The master inverter takes control of the operation, while the slave inverters adjust accordingly.
- A total of three RS485 cables should be used for inverter parallel connection to ensure reliable data transmission.

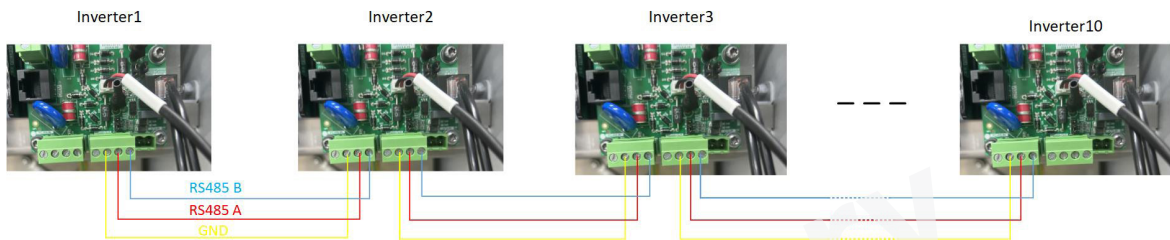

>> Rectifier Connection

If an Automatic Transfer Switch (ATS) is installed in the system:

- A 220VAC/5VDC rectifier must be integrated.
- The rectifier provides a 5VDC signal to the master inverter when the generator starts.
- This signal allows the inverter system to adjust operation accordingly and prevent any reverse power flow into the generator.

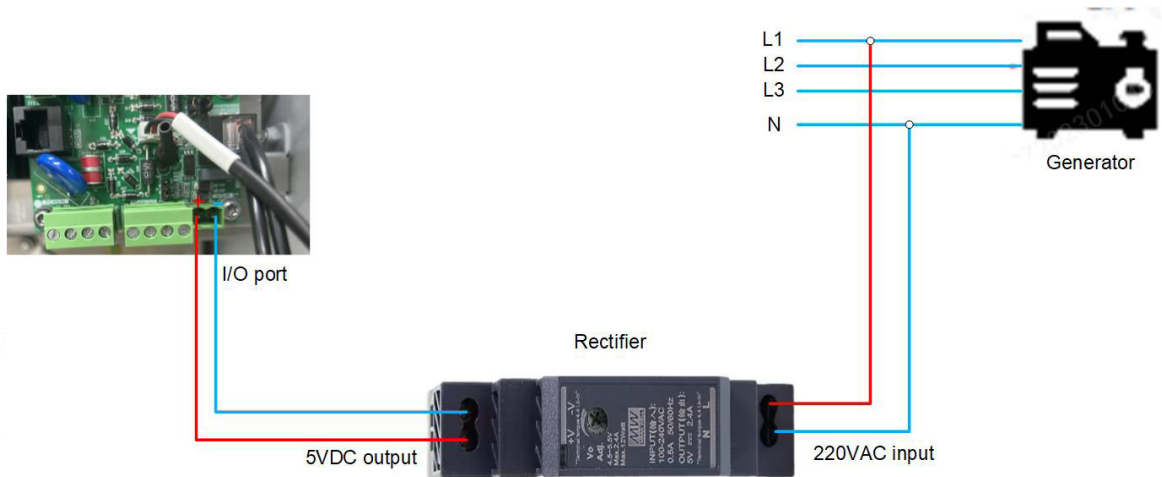

>> Steps for Setting Up the Inverter

For both off-grid and grid-connected systems, inverters must be configured correctly to ensure seamless operation.

Inverter Configuration for Off-Grid Operation

To configure the inverter for off-grid operation, follow these steps:

1) Enable EPM:

- Advanced Setting → EPM Setting → Integrated EPM Set → EPM Switch → ON

2) Set EPM Mode:

- Advanced Setting → EPM Setting → Integrated EPM Set → EPM-Mode → Wri_SYS → 3P_4W → Minimum

3) Configure Mode:

- Advanced Setting → EPM Setting → Integrated EPM Set → EPM-Mode → Mode Set → GEN

4) Set Meter Type:

- Advanced Setting → EPM Setting → Integrated EPM Set → EPM-Mode → Met Set → ADL400

5) Adjust Export Power:

- Advanced Setting → EPM Setting → Integrated EPM Set → Export Power → GEN MinP
(Recommended value: 30% of generator rated power)

6) Set Inverter ID:

- Advanced Setting → EPM Setting → Integrated EPM Set → Integrated EPM ID Setting → 1-10
(The inverter with address "1" is automatically recognized as the master inverter.)

>> Scenario 2: Grid Available & ATS Used

Follow these steps to set up the inverter:

1) Enable EPM:

- Advanced Setting → EPM Setting → Integrated EPM Set → EPM Switch → ON

2) Set EPM Mode:

- Advanced Setting → EPM Setting → Integrated EPM Set → EPM-Mode → Wri_SYS → 3P_4W → Unbalanced/Minimum

3) Configure Mode:

- Advanced Setting → EPM Setting → Integrated EPM Set → EPM-Mode → Mode Set → Auto

4) Set Meter Type:

- Advanced Setting → EPM Setting → Integrated EPM Set → EPM-Mode → Met Set → ADL400

5) Adjust Export Power:

- Advanced Setting → EPM Setting → Integrated EPM Set → Export Power → Grid Exp P
- Advanced Setting → EPM Setting → Integrated EPM Set → Export Power → GEN MinP
(Recommended value: 30% of generator rated power)

6) Set Inverter ID:

- Advanced Setting → EPM Setting → Integrated EPM Set → Integrated EPM ID Setting → 1-10
(The inverter with address "1" is automatically recognized as the master inverter.)

Note: If you are interested in this solution, or have any questions please contact us at service@ginlong.com.

Conclusion:

>> For regions with unreliable grid power or off-grid applications, integrating PV inverters in parallel with generators offers a practical and cost-efficient energy solution. By leveraging solar power and optimizing generator use, businesses and homeowners can achieve greater energy independence, lower costs, and improved sustainability. As technology advances, solutions like Solis' PV + generator integration are making clean energy more accessible and reliable for diverse applications.