

Vorläufige Prototypenbestätigung / Preliminary prototype confirmation

Nr. / No.:

968/GI 2131.00/24

Netzintegration von Erzeugungseinheiten und -anlagen

Grid integration of power generating units and systems

Antragsteller /
Applicant

Ginlong Technologies Co., Ltd.
No. 57 Jintong Road, Binhai, (seafront) industrial park,
Xiangshan, Ningbo, zhejiang, 315712,
P. R. China

Zertifizierstelle /
Certification Body

TÜV Rheinland Industrie Service GmbH
Am Grauen Stein
51105 Köln, Deutschland / Germany

Produkttyp /
Product type

Wechselrichter / Energieerzeugungseinheit (EZE) Typ 2
Inverter / Power Generating Unit (PGU) Type 2

Modell /
Model

S6-GC80K, S6-GC100K, S6-GC110K, S6-GC125K, S6-GC125K-HV

Beschreibung /
Description

Die EZE kann innerhalb ihrer Betriebsbereiche Leistung und Blindleistung bereitstellen / beziehen. Darüber hinaus bietet sie eine dynamische Blindstromspeisung bei Netzfehlern mit eingebauter Schutzfunktion. / *The PGU can supply/receive power and reactive power within its operating ranges. It also provides dynamic reactive current feed-in during grid fault with equipped protective function.*

Normen /
Standards

VDE-AR-N 4110:2023-09,
FGW TR 8 / TG8, Rev.9 (2019-02-01)

Erklärung /
Declaration

Die TÜV Rheinland Industrie Service GmbH bestätigt, dass es sich bei der genannten Energieerzeugungseinheit (EZE) Typ-2 nach VDE-AR-N 4110, sowie gemäß FGW TR 8, um einen Prototypen handelt, der in der Lage ist die technischen Anforderungen der Normen zu erfüllen. Es wird davon ausgegangen, dass die Anforderungen der FGW TR8 im Rahmen einer Zertifizierung erfüllt werden. / *TÜV Rheinland Industrie Service GmbH confirms that the mentioned Power Generating Unit (PGU Type-2) is a prototype according to VDE-AR-N 4110, as well as according to FGW TR 8, which is able to meet the technical requirements of the standards. It is assumed that the requirements of FGW TR8 are fulfilled within the scope of a certification.*

Inbetriebnahme der ersten EZE /
Commissioning of the first PGU

--

Datum / Date

2024-08-26

Gültig bis / Valid until

2026-08-26

Die Details zur Gültigkeit im Kapitel 1.3 sind entsprechend zu beachten. /
The details on validity in chapter 1.3 must be observed accordingly.

Diese Prototypenbestätigung darf nicht auszugsweise verwendet werden.

This prototype confirmation may not be used in extracts.

Köln, 2024-08-26
TÜV Rheinland Industrie Service GmbH
Am Grauen Stein, D-51105 Köln

Dipl.-Ing. Marco Klose
Specialist Certifier

M. Sc. Armin Kerperin
Assessor

1. **Aufgabenstellung / Task**

Im Rahmen dieser Prototypenbestätigung wird auf Grundlage herstellerspezifischer Dokumente überprüft, ob die genannte Energieerzeugungseinheit (EZE) die Anforderungen gemäß [N1] bis [N2] erfüllen kann.

As part of this prototype confirmation, it is checked on the basis of manufacturer-specific documents whether the named power generating unit (EZE Type-2) can meet the requirements according to [N1] to [N2].

1.1. **Normen und Technische Richtlinien / Standards and technical guidelines**

[N1] Technical Guideline for the connection of customer systems to the medium-voltage network and their operation (TAR medium voltage / VDE-AR-N 4110: 2018-11)

[N2] Technical guideline for generating units and systems part 8 revision 09 of the Fördergesellschaft Windenergie und andere Erneuerbare Energien e.V. (FGW TG8 Rev. 9)

1.2. **Für die Bestätigung verwendete Dokumente / Documents supplied for confirmation**

Für die Bewertung der EZE wurden u. a. Informationen aus den folgenden herstellerspezifischen Dokumenten entnommen.

For the evaluation of the PGU, e.g. Information taken from the following manufacturer-specific documents.

[D1] Ginlong Technologies Co., Ltd.
Declaration of VDE-AR-N 4110
Dated: 2024-03-29

[D2] Ginlong Technologies Co., Ltd.
Application for Certification
Dated: 2024-05-13

[D3] Ginlong Technologies Co., Ltd.
User manual Version 1.1

1.3. **Gültigkeit der Prototypenbestätigung / Validity of prototype confirmation**

Die Gültigkeit der ausgestellten Prototypenbestätigung beschränkt sich gemäß VDE-AR-N 4110 auf zwei Jahre nach Inbetriebsetzung des ersten Prototypen. Da zurzeit noch keine EZE von diesem Typ in Betrieb genommen worden ist, handelt es sich um eine vorläufige Prototypenbestätigung. Diese Prototypenbestätigung ist nach Inbetriebnahme des ersten Prototypen entsprechend zu revidieren und die Gültigkeit ist auf zwei Jahre nach Inbetriebsetzung der ersten EZE dieses Prototypen zu beschränken.

The validity of the prototype confirmation issued is limited to two years after commissioning of the first prototype in accordance with VDE-AR-N 4110. Since no PGU of this type has currently been commissioned, this is a provisional prototype confirmation. This prototype confirmation must be revised accordingly after commissioning of the first prototype and the validity must be limited to two years after commissioning of the first PGU of this prototype.

2. Prototypenregelung nach FGW TR 8 / Prototype regulation according to FGW TG 8

In diesem Abschnitt wird überprüft, ob es sich bei der EZE gemäß FGW TR 8 [N2] um einen Prototyp handelt. Nach [N2] ist ein Prototyp das erste Betriebsmittel eines Typs, welches wesentliche technische Weiterentwicklungen oder Neuerungen aufweist, sowie alle weiteren Betriebsmittel dieses Typs, die innerhalb von zwei Jahren nach Inbetriebsetzung des ersten Betriebsmittels dieses Typs in Betrieb gesetzt wurden. Die Regelung und Fristen von Betriebsmittelprototypen in einer EZE können den Netzanschlussregeln (NAR) entnommen werden.

In this section, it is checked whether the mentioned PGU is a prototype according to FGW TG 8 [N2]. According to [N2], the definition of the prototype is the first item of equipment of this type that has significant technical developments or innovations, as well as all other items of equipment of this type that were put into operation within two years after the first item of equipment of this type was in service. The rules and deadlines for equipment prototypes of PGU can be found in the grid connection guideline (NAR).

Gemäß [N1] gilt: Für Erzeugungsanlagen (EZA) mit EZE gleichen Prototyps müssen das Anlagenzertifikat und die Konformitätserklärung binnen eines Jahres, nachdem für den ersten Prototyp ein Einheitenzertifikat vorliegt, nachgereicht werden. Für Komponenten innerhalb der Erzeugungsanlage, für die ein Komponentenzertifikat erforderlich ist, kann die Prototypenregelung entsprechend angewendet werden.

According to [N1], the following applies: for power generating systems (PGS) with PGU of the same prototype, the plant certificate and the declaration of conformity must be submitted within one year after a unit certificate is available for the first prototype. The prototype regulation can be applied accordingly for components within the generating plant for which a component certificate is required.

Bewertung / Assessment:

FGW TR8 / TG8 (Revision 9)	Bewertung/Assessment
2.11 Betriebsmittel Prototypen / Prototype	
Herstellereklärung zur teilweisen oder vollständigen Konformität zu einer oder mehreren NAR. / <i>Manufacturer's declaration of partial or full conformity to one or more NAR.</i>	<input checked="" type="checkbox"/> Berücksichtigt / Included (Anhang 1 / Annex 1)
Herstellereklärung, dass es sich um eine wesentliche technische Weiterentwicklung bzw. Neuerung handelt. / <i>Manufacturer's declaration that it is a major technical development or innovation.</i>	<input checked="" type="checkbox"/> Berücksichtigt / Included (Anhang 1 / Annex 1)
Aufzeigen von Unterschieden zu ggf. vorhandenen und bereits zertifizierten Betriebsmitteln. / <i>Identification of differences to any existing and already certified equipment.</i>	<input checked="" type="checkbox"/> Berücksichtigt / Included (Anhang 1 / Annex 1)
Herstellereklärung, dass weitere technische Daten den Anforderungen der jeweiligen NAR entsprechen. / <i>Manufacturer's declaration that further technical data meet the requirements of the respective NAR.</i>	<input checked="" type="checkbox"/> Berücksichtigt / Included (Anhang 1 / Annex 1)

3. Prototypenregelung gemäß VDE-AR-N 4110/ Prototype regulation according to VDE-AR-N 4110

Nach [N2] muss die Zertifizierungsstelle in der Prototypenbestätigung nachvollziehbar ausweisen, dass der Prototyp grundsätzlich in der Lage ist, die Anforderungen der jeweiligen NAR an die elektrischen Eigenschaften und Funktionen der Betriebsmittel zu erfüllen.

According to [N2], the certification body must clearly state in the prototype confirmation that the prototype is basically able to meet the requirements of the respective NAR for the electrical properties and functions of the equipment.

Die Vorgaben der NAR an den Prüfumfang für die Prototypenbestätigung sind zu berücksichtigen (sofern vorhanden). Im Folgenden wird dazu die Übereinstimmung der elektrischen Eigenschaften des EZE- mit den Anforderungen nach [N1] überprüft.

The specifications of the NAR for the scope of testing for the prototype confirmation must be taken into account (if available). In the following, the compliance of the electrical properties of the PGU with the requirements of [N1] is checked.

Bewertung / Assessment:

Art der Betriebsmittel Type	EZE / PGU		Komponenten / Components			
	PV	Speicher / Storage System	EZA-Regler / PGU Controller	Kompensations- einrichtung / Compensation equipment	Schutzein- richtungen / Protective devices	
	<input checked="" type="checkbox"/>	<input type="checkbox"/>	<input type="checkbox"/>	<input type="checkbox"/>	<input type="checkbox"/>	
Anmerkung Annotation	Die folgenden Punkte 1), 2) und 4) sind anzuwenden. <i>The following items 1), 2) and 4) are applied.</i>		Die folgenden Punkte 1), 2), 3) und 4) sind anzuwenden. <i>The following items 1), 2), 3) and 4) are applied.</i>			
Anforderungen an Prototypen gemäß VDE-AR-N 4110 Requirements for Prototypes according to VDE-AR-N 4110						
Nr.	Anforderungen / Requirements					Bewertung / Evaluation
1)	Der Prototyp weist wesentliche technische Weiterentwicklungen oder Neuerungen auf. / <i>The prototype shows significant technical developments or innovations.</i>					<input checked="" type="checkbox"/> Zutreffend/ Applied
2)	Der Prototyp ist grundsätzlich in der Lage die Anforderungen dieser VDE-Richtlinie an die elektrischen Eigenschaften zu erfüllen. / <i>The prototype is basically able to meet the requirements of this VDE guideline for the electrical properties.</i>					<input checked="" type="checkbox"/> Zutreffend/ Applied
3)	Für Komponenten innerhalb der Erzeugungsanlage, für die ein Komponentenzertifikat erforderlich ist, kann die Prototypenregelung entsprechend angewandt werden. <i>For components within the power generating plant, for which a component certificate is required, the prototype regulation can be applied in analogy.</i>					<input type="checkbox"/> Zutreffend/ Applied
4)	Anforderungen an die Angaben der Datenblätter und darauf basierende Plausibilitätsprüfung (PP) / <i>Requirements for the information in the data sheets and the plausibility check (PP) based on them</i>					

a) Herstellererklärung, dass die Erzeugungseinheit so konstruiert wurde, dass die Anforderungen der VDE erfüllt werden können. / <i>Manufacturer's declaration that the generating unit was constructed in such a way that the requirements of the VDE can be met.</i>	<input checked="" type="checkbox"/> Enthalten/ <i>Included</i>
PP: <input checked="" type="checkbox"/> Erfüllt (Anhang 1) / <i>Fulfilled (Annex 1)</i> <input type="checkbox"/> Entfällt / <i>Not applicable</i>	
b) Schematisches Übersichtsbild der Erzeugungseinheit mit allen wesentlichen Komponenten / <i>Schematic overview of the generating unit with all essential components</i>	<input checked="" type="checkbox"/> Enthalten/ <i>Included</i>
PP: <input checked="" type="checkbox"/> Erfüllt (Anhang 1) / <i>Fulfilled (Annex 1)</i> <input type="checkbox"/> Entfällt / <i>Not applicable</i>	
c) Elektrische Daten (Nenn- und Bemessungsgrößen) / <i>Electrical data (nominal and rated values)</i>	<input checked="" type="checkbox"/> Enthalten/ <i>Included</i>
PP: <input checked="" type="checkbox"/> Erfüllt (Anhang 1) / <i>Fulfilled (Annex 1)</i> <input type="checkbox"/> Entfällt (keine Anforderungen an EZA-Regler) / <i>Not applicable for PGU controllers</i>	
d) Schutzfunktionen mit Einstellbereichen / <i>Protection functions with setting ranges</i> Entkupplungsschutz / <i>Decoupling protection</i> Eigenschutz / <i>Self-protection</i>	<input checked="" type="checkbox"/> Enthalten/ <i>Included</i>
PP: <input checked="" type="checkbox"/> Erfüllt (Anhang 1) / <i>Fulfilled (Annex 1)</i> <input type="checkbox"/> Entfällt (keine Anforderungen an EZA-Regler) / <i>Not applicable for PGU controllers</i>	
e) Betriebsbereich der Erzeugungseinheit: / <i>Operating range of the generating unit</i> Grenzen im quasistationären Betrieb / <i>Limits in quasi-steady state operation</i> Blindleistungsstellbereich / <i>Reactive power adjustment range</i> FRT-Grenzkurve (U/t-Diagramm) / <i>FRT limit curve (U/t diagram)</i>	<input checked="" type="checkbox"/> Enthalten/ <i>Included</i>
PP: <input checked="" type="checkbox"/> Erfüllt (Anhang 1) / <i>Fulfilled (Annex 1)</i> <input type="checkbox"/> Entfällt (keine Anforderungen an EZA-Regler) / <i>Not applicable for PGU controllers</i>	
f) Wirkleistungsregelung: / <i>Active power control</i> Leistungs-Frequenz-Verhalten; / <i>Power frequency regulation</i> Wirkleistungsgradient / <i>Active power ramping</i>	<input checked="" type="checkbox"/> Enthalten <i>Included</i>
PP: <input checked="" type="checkbox"/> <i>fulfilled: the active power can be regulated by following methods (Annex 1):</i> - Power/frequency behavior $P = f(f, Pref)$ - Power/Voltage behavior $P = f(v)$ - Active power ramping <input type="checkbox"/> Entfällt / <i>Not applicable</i>	
g) Blindleistungsregelung / <i>Reactive power control regulated by</i> - Fixed Q - Fixed $\cos \varphi$ - Voltage-dependent reactive power $Q(U)$ - Active power Dependent reactive power $Q(P)$	<input checked="" type="checkbox"/> Enthalten <i>Included</i> <input type="checkbox"/> Entfällt für EZA-Regler / <i>Not applicable</i>
PP: <input checked="" type="checkbox"/> Erfüllt (Anhang 1) / <i>Fulfilled (Annex 1):</i> <input type="checkbox"/> Entfällt (keine Anforderung an EZA-Regler) / <i>Not applicable</i>	
h) Spannungsstützung bei Netzfehlern durch Blindstromspeisung bei dynamischer Netzstützung / <i>Dynamic reactive current feed-in functionality</i>	<input checked="" type="checkbox"/> Enthalten <i>Included</i>
PP: <input checked="" type="checkbox"/> Erfüllt (Anhang 1) / <i>Fulfilled (Annex 1)</i> <input type="checkbox"/> Entfällt / <i>Not applicable</i>	

Votum des Fachauditors / Conclusion

Die TÜV Rheinland Industrie Service GmbH bestätigt, dass es sich bei der genannten EZE nach [N1], sowie gemäß [N2], um einen Prototypen handelt, der in der Lage ist die technischen Anforderungen der Normen zu erfüllen. Es wird davon ausgegangen, dass die Anforderungen von [N2] im Rahmen einer Zertifizierung erfüllt werden.

TÜV Rheinland Industrie Service GmbH confirms that the mentioned PGU according to [N1], as well as according to [N2], is a prototype that is able to meet the technical requirements of the standards. It is assumed that the requirements of [N2] are met within the framework of a certification.

Die Bewertung ergab keine Beanstandungen.
The evaluation did not result in any objections.

Anhang / Annex
Anhang 1 / Annex 1:
Manufacturer's Declaration



Declaration of VDE-AR-N 4110

Ginlong technologies Co., Ltd.

S6-GC 80-125K Series

Version: V 1.0

Signature:

A handwritten signature in black ink that reads "Pan Ruyi".

Date: 29.03.2024

Declaration of VDE-AR-N 4110

Page 2 of 27



S6-GC 80-125K Series apply prototype and unit certificate as a new series.

S6-GC 80-125K series is a brand-new series, and the difference with Solis-(80-125) K-5G-PRO series is mainly embodied in the hardware design. Solis-(80-125) K-5G-PRO series adopts four groups of inverter modules, which can run independently. The S6-GC 80-125K series adopts a single inverter module.

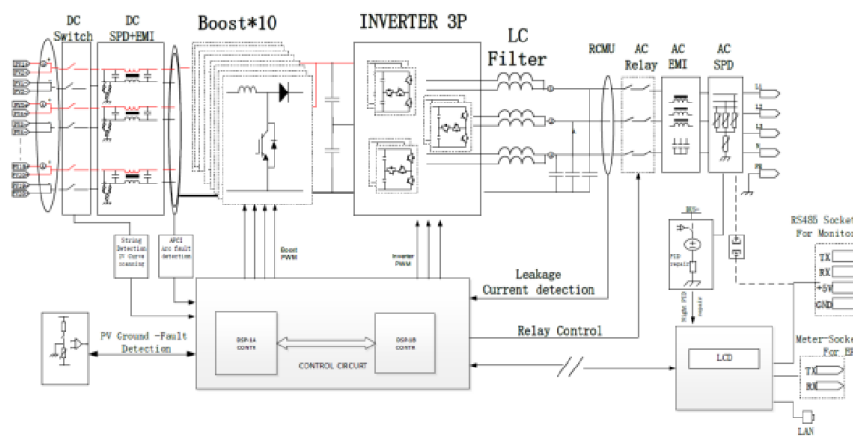

Block Diagramm for S6-GC 80-125K Series

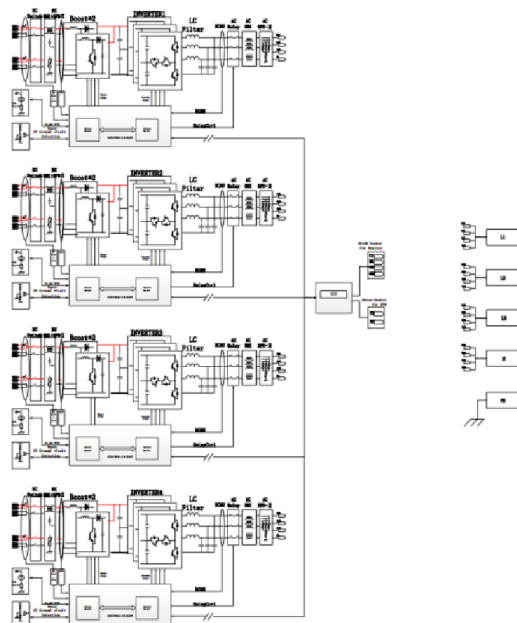

Block Diagramm for Solis-(80-125) K-5G-PRO

Declaration of VDE-AR-N 4110

Page 3 of 27



1. Company Information

License Holder: Ginlong technologies Co., Ltd.

Address: No.57 Jintong Road, Binhai, (seafront) industrial Park, Xiangshan, Ningbo, Zhejiang
315712, P.R. China

Product Type: S6-GC80K, S6-GC100K, S6-GC110K, S6-GC125K, S6-GC125K-HV

2. **Product Datasheet:** See following page.

Declaration of VDE-AR-N 4110

Page 4 of 27



























Product Model:	S6-GC80K	S6-GC100K	S6-GC110K	S6-GC125K	S6-GC125K-HV
d.c.Max.Input Voltage:	1100 Vd.c				
d.c.Input Voltage Range:	160-1000 Vd.c				
d.c.Max.Input Current:	4*42A 4*36A	5*42A 5*36A	5*42A 5*36A	5*42A 5*36A	5*42A 5*36A
d.c.Shorted Input Current:	8*50 A	10*50 A	10*50 A	10*50 A	10*50 A
a.c.Rated Output Voltage:	3/N/PE, 220/380V, 230/400V	3/N/PE, 220/380V, 230/400V	3/N/PE, 220/380V, 230/400V	3/N/PE, 220/380V, 230/400V	3/PE, 480 V
a.c.Rated Output Frequency:	50Hz / 60Hz				
a.c.Max.Output Current:	133.7 A	167.1 A	183.8 A	189.9A	165.4 A
a.c.Rated Output Power:	80 kW	100 kW	110 kW	125 kW	125 kW
Max.Apparent Power:	88 kVA	110 kVA	121 kVA	125 kVA	137.5 kVA
Adjustable Power Factor Range:	0.8(lagging)~0.8(leading)				
Enclosure:	IP66				
Temperature Range:	-30°C ~ +60°C				
Voltage measure accuracy	±1% Un				
Frequency measure accuracy	±0.05Hz				
Firmware:	A1				
Hardware:	V2				
Protective Class:	I				

Declaration of VDE-AR-N 4110

Page 5 of 27

















3. Rating Label

					
Model:	S6-GC80K	Model:	S6-GC100K	Model:	S6-GC110K
Max.input voltage d.c.	1100V	Max.input voltage d.c.	1100V	Max.input voltage d.c.	1100V
Mppt voltage range d.c.	160-1000V	Mppt voltage range d.c.	160-1000V	Mppt voltage range d.c.	160-1000V
Max.input current d.c.	42A*4+36A*4	Max.input current d.c.	42A*5+36A*5	Max.input current d.c.	42A*5+36A*5
Isc PV(absolute maximum) d.c.	50A*8	Isc PV(absolute maximum) d.c.	50A*10	Isc PV(absolute maximum) d.c.	50A*10
Rated grid voltage a.c.	3/N/PE,220/380V 3/N/PE,230/400V	Rated grid voltage a.c.	3/N/PE,220/380V 3/N/PE,230/400V	Rated grid voltage a.c.	3/N/PE,220/380V 3/N/PE,230/400V
Rated grid frequency	50/60Hz	Rated grid frequency	50/60Hz	Rated grid frequency	50/60Hz
Rated output power	80000W	Rated output power	100000W	Rated output power	110000W
Max.AC output active power	88000W	Max.AC output active power	110000W	Max.AC output active power	121000W
Max.AC output apparent power	88000VA	Max.AC output apparent power	110000VA	Max.AC output apparent power	121000VA
Max.continuous output current a.c.	133.7A	Max.continuous output current a.c.	167.1A	Max.continuous output current a.c.	183.8A
Adjustable cos(φ)	-0.8...1...+0.8	Adjustable cos(φ)	-0.8...1...+0.8	Adjustable cos(φ)	-0.8...1...+0.8
Operating temperature range	-30...+60°C	Operating temperature range	-30...+60°C	Operating temperature range	-30...+60°C
Ingress protection	IP66	Ingress protection	IP66	Ingress protection	IP66
Protective class	I	Protective class	I	Protective class	I
Overvoltage category	II(PV) III(MAINS)	Overvoltage category	II(PV) III(MAINS)	Overvoltage category	II(PV) III(MAINS)
Inverter topology	Non-isolated	Inverter topology	Non-isolated	Inverter topology	Non-isolated
 S/N: 120030199180004		 S/N: 120030199180005		 S/N: 120030199180006	
     	Name: Ginlong Technologies Co.,Ltd. Address:No.57 Jintong Road,Binhai Industrial Park, Xiangshan,Zhejiang,China,315712 www.solisinverters.com Made in China	     	Name: Ginlong Technologies Co.,Ltd. Address:No.57 Jintong Road,Binhai Industrial Park, Xiangshan,Zhejiang,China,315712 www.solisinverters.com Made in China	     	Name: Ginlong Technologies Co.,Ltd. Address:No.57 Jintong Road,Binhai Industrial Park, Xiangshan,Zhejiang,China,315712 www.solisinverters.com Made in China



Declaration of VDE-AR-N 4110

Page 6 of 27

			
Model: S6-GC125K		Model: S6-GC125K-HV	
Max. input voltage d.c.	1100V	Max. input voltage d.c.	1100V
Mppt voltage range d.c.	160-1000V	Mppt voltage range d.c.	160-1000V
Max. input current d.c.	42A*5+36A*5	Max. input current d.c.	42A*5+36A*5
Isc PV(absolute maximum) d.c.	50A*10	Isc PV(absolute maximum) d.c.	50A*10
Rated grid voltage a.c.	3/N/PE, 220/380V 3/N/PE, 230/400V	Rated grid voltage a.c.	3/PE, 480 V
Rated grid frequency	50/60Hz	Rated grid frequency	50/60Hz
Rated output power	125000W	Rated output power	125000W
Max.AC output active power	125000W	Max.AC output active power	137500W
Max.AC output apparent power	125000VA	Max.AC output apparent power	137500VA
Max.continuous output current a.c.	189.9A	Max.continuous output current a.c.	165.4A
Adjustable cos(φ)	-0.8...1...+0.8	Adjustable cos(φ)	-0.8...1...+0.8
Operating temperature range	-30...+60°C	Operating temperature range	-30...+60°C
Ingress protection	IP66	Ingress protection	IP66
Protective class	I	Protective class	I
Overvoltage category	II(PV) III(MAINS)	Overvoltage category	II(PV) III(MAINS)
Inverter topology	Non-isolated	Inverter topology	Non-isolated
 S/N: 120030199180010		 S/N: 120030199180012	
    		    	
Name: Ginlong Technologies Co.,Ltd. Address:No.57 Jintong Road,Binhai Industrial Park, Xiangshan,Zhejiang,China,315712 www.solisinverters.com Made in China		Name: Ginlong Technologies Co.,Ltd. Address:No.57 Jintong Road,Binhai Industrial Park, Xiangshan,Zhejiang,China,315712 www.solisinverters.com Made in China	

Declaration of VDE-AR-N 4110

Page 7 of 27



4. Product description:

The PCE under test (EUT) is Grid-connected PV Inverter which utilizes the advanced power electronics conversion components IGBT to convert the variable DC power generated from the photovoltaic (PV) arrays to the stable utility AC power which can be fed into the commercial electrical grid.

The PCE series under test is three-phase grid-connected PV inverter for solar power generation with the rating of 80kW-125kW. All models are identical in hardware and software except for MPPT numbers, electrical ratings and model name.

The block diagrams of products areas below, amount of input terminals may have difference:

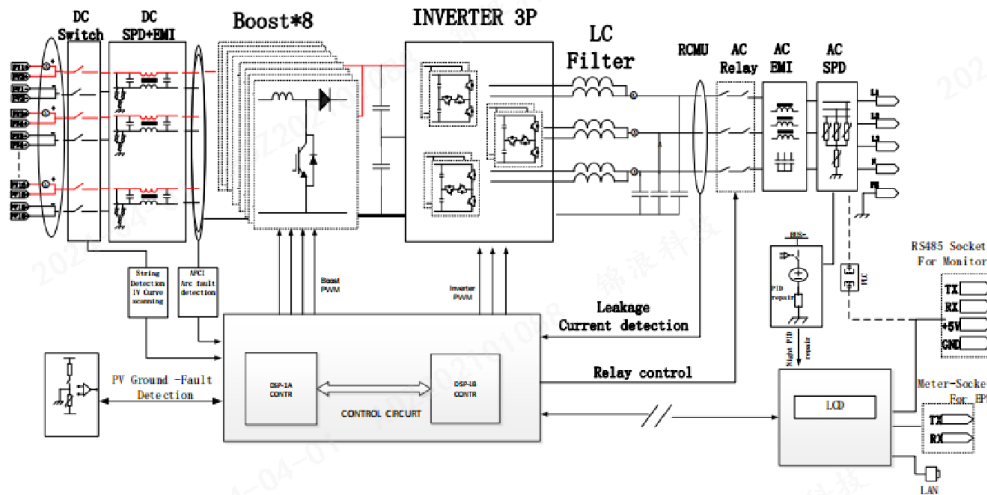

For model S6-GC80K

Declaration of VDE-AR-N 4110

Page 8 of 27

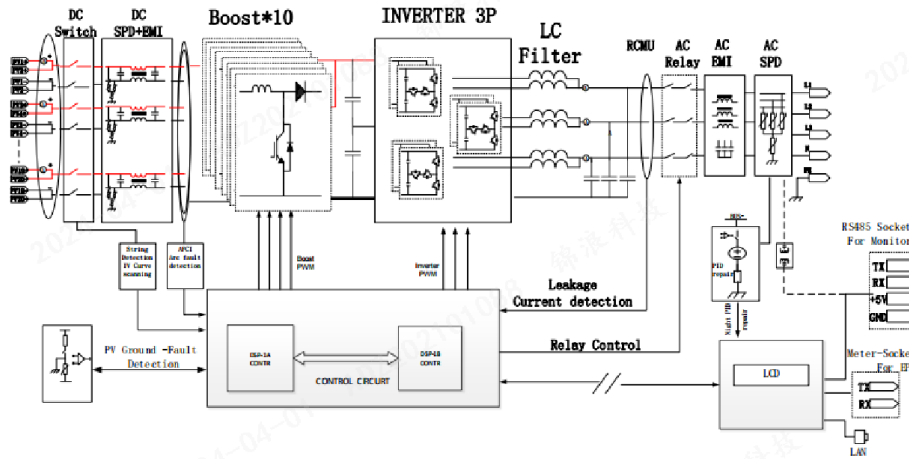

For models S6-GC100K, S6-GC110K, S6-GC125K, S6-GC125K-HV

Declaration of VDE-AR-N 4110

Page 9 of 27

5. PQ diagram:



S6-GC80K								
P [p.u.]	Direction	Qmax [p.u.]						
		85 % UN	90 % UN	95 % UN	100 % UN	105 % UN	110 % UN	115 % UN
0	Underexcited	-0.6	-0.6	-0.6	-0.6	-0.6	-0.6	-0.6
	Overexcited	0.6	0.6	0.6	0.6	0.6	0.6	0.6
0.1	Underexcited	-0.6	-0.6	-0.6	-0.6	-0.6	-0.6	-0.6
	Overexcited	0.6	0.6	0.6	0.6	0.6	0.6	0.6
0.2	Underexcited	-0.6	-0.6	-0.6	-0.6	-0.6	-0.6	-0.6
	Overexcited	0.6	0.6	0.6	0.6	0.6	0.6	0.6
0.3	Underexcited	-0.6	-0.6	-0.6	-0.6	-0.6	-0.6	-0.6
	Overexcited	0.6	0.6	0.6	0.6	0.6	0.6	0.6
0.4	Underexcited	-0.6	-0.6	-0.6	-0.6	-0.6	-0.6	-0.6
	Overexcited	0.6	0.6	0.6	0.6	0.6	0.6	0.6
0.5	Underexcited	-0.6	-0.6	-0.6	-0.6	-0.6	-0.6	-0.6
	Overexcited	0.6	0.6	0.6	0.6	0.6	0.6	0.6
0.6	Underexcited	-0.6	-0.6	-0.6	-0.6	-0.6	-0.6	-0.6
	Overexcited	0.6	0.6	0.6	0.6	0.6	0.6	0.6
0.7	Underexcited	-0.6	-0.6	-0.6	-0.6	-0.6	-0.6	-0.6
	Overexcited	0.6	0.6	0.6	0.6	0.6	0.6	0.6
0.8	Underexcited	-0.56	-0.6	-0.6	-0.6	-0.6	-0.6	-0.6
	Overexcited	0.56	0.6	0.6	0.6	0.6	0.6	0.6
0.9	Underexcited	-0.38	-0.51	-0.6	-0.6	-0.6	-0.6	-0.6
	Overexcited	0.38	0.51	0.6	0.6	0.6	0.6	0.6
1.0	Underexcited	0	-0.27	-0.45	-0.46	-0.46	-0.46	-0.46
	Overexcited	0	0.27	0.45	0.46	0.46	0.46	0.46
1.1	Underexcited	0	0	0	0	0	0	0
	Overexcited	0	0	0	0	0	0	0

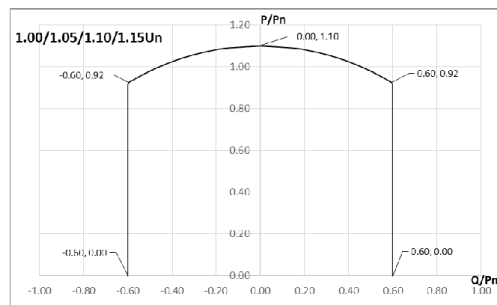
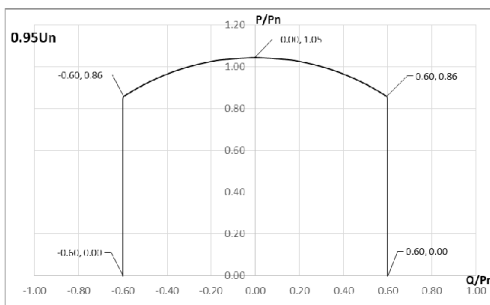
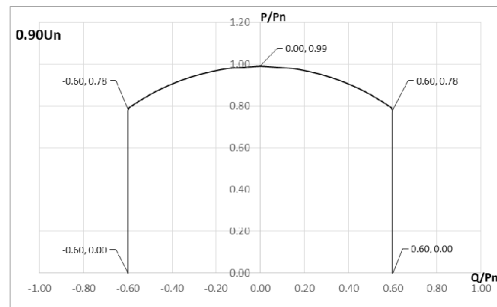
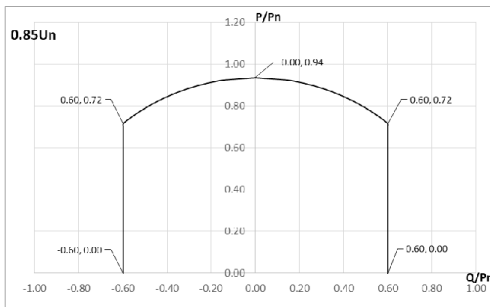

Declaration of VDE-AR-N 4110

Page 10 of 27



S6-GC-100K								
P [p.u.]	Direction	Qmax [p.u.]						
		85 % U _N	90 % U _N	95 % U _N	100 % U _N	105 % U _N	110 % U _N	115 % U _N
0	Underexcited	-0.6	-0.6	-0.6	-0.6	-0.6	-0.6	-0.6
	Overexcited	0.6	0.6	0.6	0.6	0.6	0.6	0.6
0.1	Underexcited	-0.6	-0.6	-0.6	-0.6	-0.6	-0.6	-0.6
	Overexcited	0.6	0.6	0.6	0.6	0.6	0.6	0.6
0.2	Underexcited	-0.6	-0.6	-0.6	-0.6	-0.6	-0.6	-0.6
	Overexcited	0.6	0.6	0.6	0.6	0.6	0.6	0.6
0.3	Underexcited	-0.6	-0.6	-0.6	-0.6	-0.6	-0.6	-0.6
	Overexcited	0.6	0.6	0.6	0.6	0.6	0.6	0.6
0.4	Underexcited	-0.6	-0.6	-0.6	-0.6	-0.6	-0.6	-0.6
	Overexcited	0.6	0.6	0.6	0.6	0.6	0.6	0.6
0.5	Underexcited	-0.6	-0.6	-0.6	-0.6	-0.6	-0.6	-0.6
	Overexcited	0.6	0.6	0.6	0.6	0.6	0.6	0.6
0.6	Underexcited	-0.6	-0.6	-0.6	-0.6	-0.6	-0.6	-0.6
	Overexcited	0.6	0.6	0.6	0.6	0.6	0.6	0.6
0.7	Underexcited	-0.6	-0.6	-0.6	-0.6	-0.6	-0.6	-0.6
	Overexcited	0.6	0.6	0.6	0.6	0.6	0.6	0.6
0.8	Underexcited	-0.56	-0.6	-0.6	-0.6	-0.6	-0.6	-0.6
	Overexcited	0.56	0.6	0.6	0.6	0.6	0.6	0.6
0.9	Underexcited	-0.38	-0.51	-0.6	-0.6	-0.6	-0.6	-0.6
	Overexcited	0.38	0.51	0.6	0.6	0.6	0.6	0.6
1.0	Underexcited	0	-0.27	-0.44	-0.46	-0.46	-0.46	-0.46
	Overexcited	0	0.27	0.44	0.46	0.46	0.46	0.46
1.1	Underexcited	0	0	0	0	0	0	0
	Overexcited	0	0	0	0	0	0	0

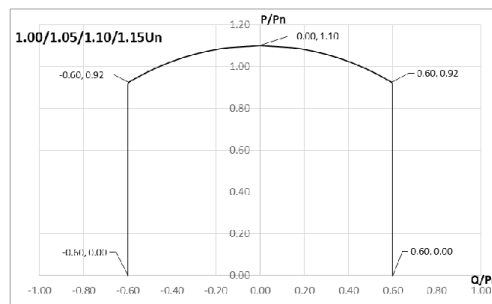
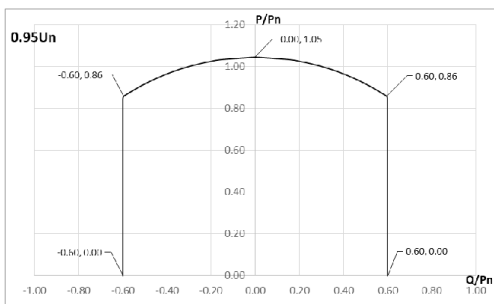
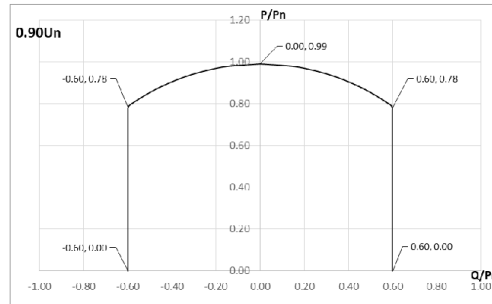
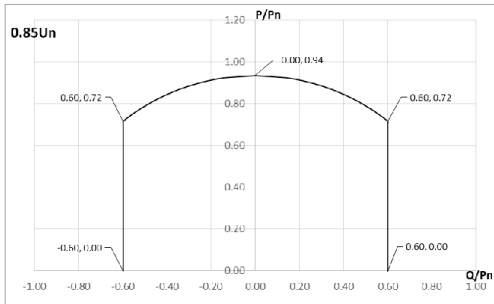

Declaration of VDE-AR-N 4110



Page 11 of 27

S6-GC- 110K								
P [p.u.]	Direction	Qmax [p.u.]						
		85 % U _N	90 % U _N	95 % U _N	100 % U _N	105 % U _N	110 % U _N	115 % U _N
0	Underexcited	-0.6	-0.6	-0.6	-0.6	-0.6	-0.6	-0.6
	Overexcited	0.6	0.6	0.6	0.6	0.6	0.6	0.6
0.1	Underexcited	-0.6	-0.6	-0.6	-0.6	-0.6	-0.6	-0.6
	Overexcited	0.6	0.6	0.6	0.6	0.6	0.6	0.6
0.2	Underexcited	-0.6	-0.6	-0.6	-0.6	-0.6	-0.6	-0.6
	Overexcited	0.6	0.6	0.6	0.6	0.6	0.6	0.6
0.3	Underexcited	-0.6	-0.6	-0.6	-0.6	-0.6	-0.6	-0.6
	Overexcited	0.6	0.6	0.6	0.6	0.6	0.6	0.6
0.4	Underexcited	-0.6	-0.6	-0.6	-0.6	-0.6	-0.6	-0.6
	Overexcited	0.6	0.6	0.6	0.6	0.6	0.6	0.6
0.5	Underexcited	-0.6	-0.6	-0.6	-0.6	-0.6	-0.6	-0.6
	Overexcited	0.6	0.6	0.6	0.6	0.6	0.6	0.6
0.6	Underexcited	-0.6	-0.6	-0.6	-0.6	-0.6	-0.6	-0.6
	Overexcited	0.6	0.6	0.6	0.6	0.6	0.6	0.6
0.7	Underexcited	-0.6	-0.6	-0.6	-0.6	-0.6	-0.6	-0.6
	Overexcited	0.6	0.6	0.6	0.6	0.6	0.6	0.6
0.8	Underexcited	-0.56	-0.6	-0.6	-0.6	-0.6	-0.6	-0.6
	Overexcited	0.56	0.6	0.6	0.6	0.6	0.6	0.6
0.9	Underexcited	-0.38	-0.51	-0.6	-0.6	-0.6	-0.6	-0.6
	Overexcited	0.38	0.51	0.6	0.6	0.6	0.6	0.6
1.0	Underexcited	0	-0.27	-0.44	-0.46	-0.46	-0.46	-0.46
	Overexcited	0	0.27	0.44	0.46	0.46	0.46	0.46
1.1	Underexcited	0	0	0	0	0	0	0
	Overexcited	0	0	0	0	0	0	0

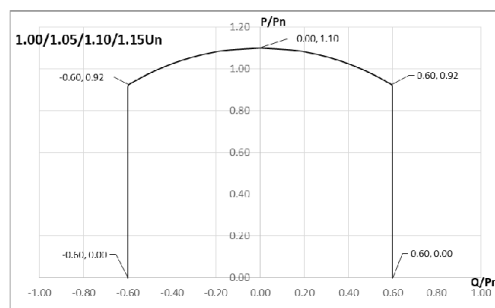
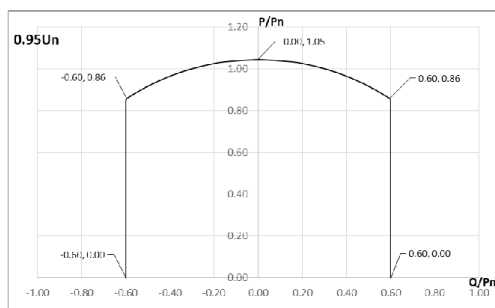
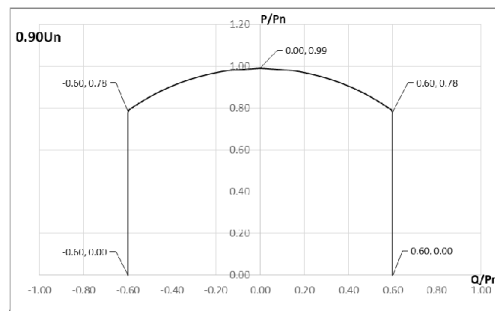
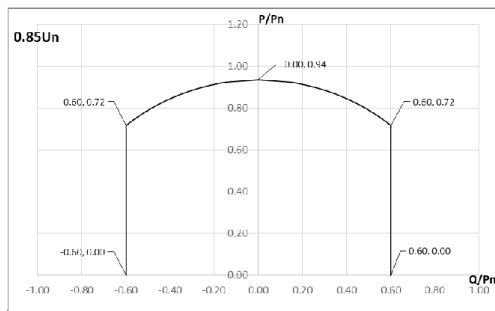

Declaration of VDE-AR-N 4110

Page 12 of 27



S6- GC125K								
P [p.u.]	Direction	Q _{max} [p.u.]						
		85 % U _N	90 % U _N	95 % U _N	100 % U _N	105 % U _N	110 % U _N	115 % U _N
0	Underexcited	-0.6	-0.6	-0.6	-0.6	-0.6	-0.6	-0.6
	Overexcited	0.6	0.6	0.6	0.6	0.6	0.6	0.6
0.1	Underexcited	-0.6	-0.6	-0.6	-0.6	-0.6	-0.6	-0.6
	Overexcited	0.6	0.6	0.6	0.6	0.6	0.6	0.6
0.2	Underexcited	-0.6	-0.6	-0.6	-0.6	-0.6	-0.6	-0.6
	Overexcited	0.6	0.6	0.6	0.6	0.6	0.6	0.6
0.3	Underexcited	-0.6	-0.6	-0.6	-0.6	-0.6	-0.6	-0.6
	Overexcited	0.6	0.6	0.6	0.6	0.6	0.6	0.6
0.4	Underexcited	-0.6	-0.6	-0.6	-0.6	-0.6	-0.6	-0.6
	Overexcited	0.6	0.6	0.6	0.6	0.6	0.6	0.6
0.5	Underexcited	-0.6	-0.6	-0.6	-0.6	-0.6	-0.6	-0.6
	Overexcited	0.6	0.6	0.6	0.6	0.6	0.6	0.6
0.6	Underexcited	-0.6	-0.6	-0.6	-0.6	-0.6	-0.6	-0.6
	Overexcited	0.6	0.6	0.6	0.6	0.6	0.6	0.6
0.7	Underexcited	-0.6	-0.6	-0.6	-0.6	-0.6	-0.6	-0.6
	Overexcited	0.6	0.6	0.6	0.6	0.6	0.6	0.6
0.8	Underexcited	-0.48	-0.58	-0.6	-0.6	-0.6	-0.6	-0.6
	Overexcited	0.48	0.58	0.6	0.6	0.6	0.6	0.6
0.9	Underexcited	-0.24	-0.41	-0.53	-0.6	-0.6	-0.6	-0.6
	Overexcited	0.24	0.41	0.53	0.6	0.6	0.6	0.6
1.0	Underexcited	0	0	0.3	-0.45	-0.45	-0.45	-0.45
	Overexcited	0	0	0.3	0.45	0.45	0.45	0.45

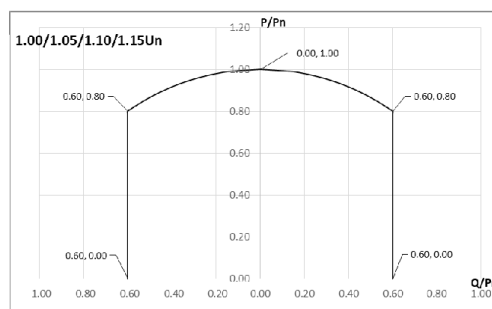
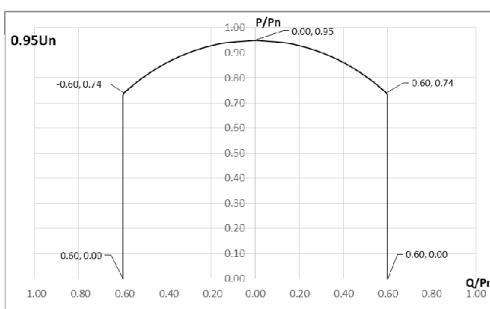
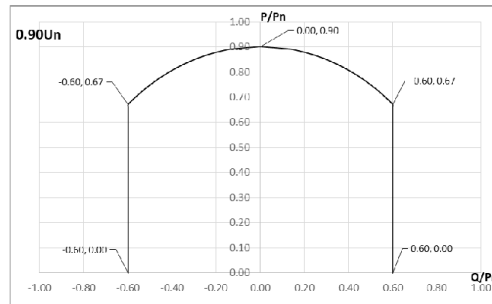
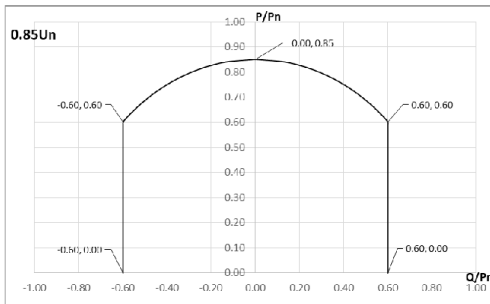

Declaration of VDE-AR-N 4110

Page 13 of 27



S6-GC 125K-HV								
P [p.u.]	Direction	Qmax [p.u.]						
		85 % U _N	90 % U _N	95 % U _N	100 % U _N	105 % U _N	110 % U _N	115 % U _N
0	Underexcited	-0.6	-0.6	-0.6	-0.6	-0.6	-0.6	-0.6
	Overexcited	0.6	0.6	0.6	0.6	0.6	0.6	0.6
0.1	Underexcited	-0.6	-0.6	-0.6	-0.6	-0.6	-0.6	-0.6
	Overexcited	0.6	0.6	0.6	0.6	0.6	0.6	0.6
0.2	Underexcited	-0.6	-0.6	-0.6	-0.6	-0.6	-0.6	-0.6
	Overexcited	0.6	0.6	0.6	0.6	0.6	0.6	0.6
0.3	Underexcited	-0.6	-0.6	-0.6	-0.6	-0.6	-0.6	-0.6
	Overexcited	0.6	0.6	0.6	0.6	0.6	0.6	0.6
0.4	Underexcited	-0.6	-0.6	-0.6	-0.6	-0.6	-0.6	-0.6
	Overexcited	0.6	0.6	0.6	0.6	0.6	0.6	0.6
0.5	Underexcited	-0.6	-0.6	-0.6	-0.6	-0.6	-0.6	-0.6
	Overexcited	0.6	0.6	0.6	0.6	0.6	0.6	0.6
0.6	Underexcited	-0.6	-0.6	-0.6	-0.6	-0.6	-0.6	-0.6
	Overexcited	0.6	0.6	0.6	0.6	0.6	0.6	0.6
0.7	Underexcited	-0.6	-0.6	-0.6	-0.6	-0.6	-0.6	-0.6
	Overexcited	0.6	0.6	0.6	0.6	0.6	0.6	0.6
0.8	Underexcited	-0.48	-0.58	-0.6	-0.6	-0.6	-0.6	-0.6
	Overexcited	0.48	0.58	0.6	0.6	0.6	0.6	0.6
0.9	Underexcited	-0.24	-0.41	-0.53	-0.6	-0.6	-0.6	-0.6
	Overexcited	0.24	0.41	0.53	0.6	0.6	0.6	0.6
1.0	Underexcited	0	0	-0.3	-0.46	-0.46	-0.46	-0.46
	Overexcited	0	0	0.3	0.46	0.46	0.46	0.46
1.1	Underexcited	0	0	0	0	0	0	0
	Overexcited	0	0	0	0	0	0	0

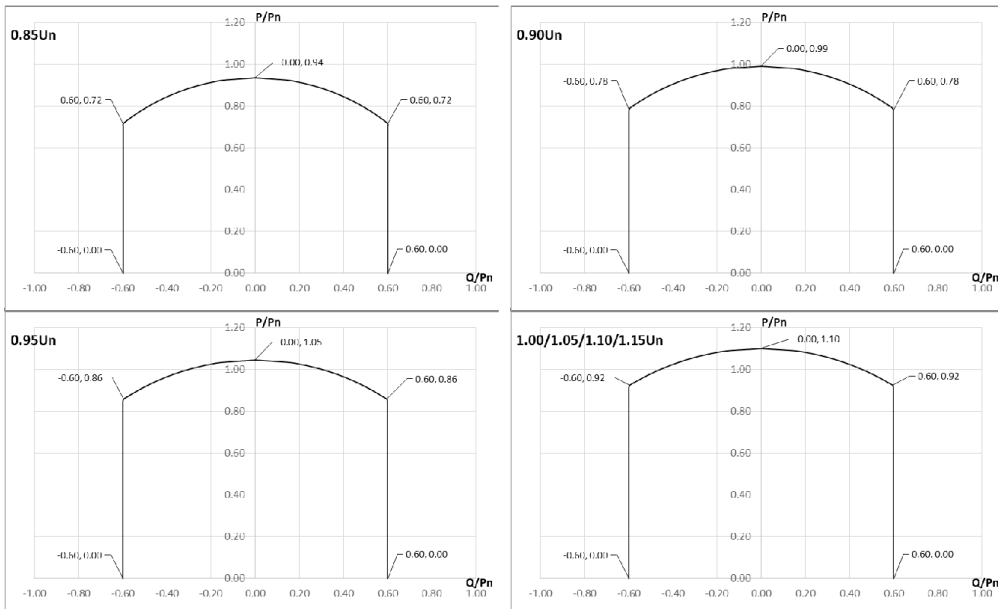



Declaration of VDE-AR-N 4110

Page 14 of 27

6. Methods for reactive power control

The reactive power is always prioritised over active power.

The P-Q relation in normal operation always follow the equation:

$$S = \min(U \cdot I, \min(S_{max}, U \cdot I_{max}))$$

$$P = \sqrt{S^2 - Q^2}$$

a. Reactive power-voltage character curve Q(U)

Reactive power-voltage character curve Q(U):			
Parameter	Setting range	Setting step	Default value
Reactive power node (Q1-Q4)	Q1: 0...0.6Pn Q2: -0.6Pn...0.6Pn Q3: -0.6Pn...0.6Pn Q4: -0.6Pn...0	0.01Pn	Q1: 0.44Pn Q2: 0 Q3: 0 Q4: -0.44Pn
Voltage node (Voltage1- Voltage4)	Voltage1: 0.93Un...1.00Un Voltage2: 0.95Un...1.00Un Voltage3: 1.00Un...1.05Un Voltage4: 1.00Un...1.07Un	0.01Un	Voltage1: 0.96Un Voltage2: 1.00Un Voltage3: 1.00Un Voltage4: 1.04Un
Settling time 3Tau	6s...60s	1s	10s

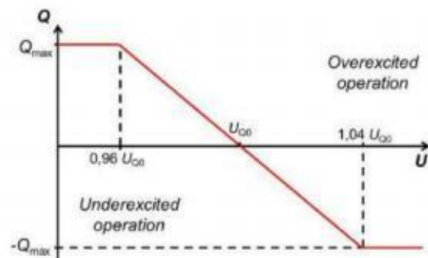

Fig. 4-166: Q(U) characteristic for use in the test

b. Character curve Q(P)

Character curve Q(P)			
Parameter	Setting range	Setting step	Default value
Reactive Power Node (Q1-Q5)	Q1: -0.6Pn...0.6Pn Q2: -0.6Pn...0.6Pn Q3: -0.6Pn...0.6Pn Q4: -0.6Pn...0.6Pn Q5: -0.6Pn...0.6Pn	0.01Pn	Q1: 0 Q2: 0 Q3: -0.05Pn Q4: -0.33Pn Q5: -0.33Pn
Active Power Node (P1-P5)	P1: 0...1.0Pn P2: 0...1.0Pn P3: 0...1.0Pn P4: 0...1.0Pn P5: 0...1.0Pn	0.1Pn	P1: 0 P2: 0.5Pn P3: 0.6Pn P4: 0.9Pn P5: 1.0Pn
Settling time 3Tau	6s...60s	1s	10s

Declaration of VDE-AR-N 4110

Page 15 of 27

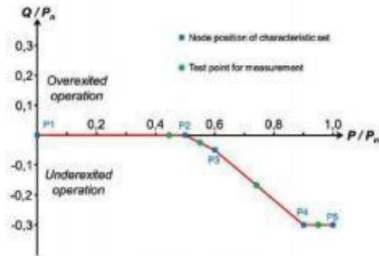

Fig. 4-177: Q(P) characteristic for test

c. Fixed Q

Fixed Q			
Parameter	Setting range	Setting step	Default value
Reactive power Q React. Power	-0.6Pn...0.6Pn	0.01Pn	Q=0
Reactive power Q in com loss condition	--	--	last set-point received
Settling time 3Tau	6s...60s	1s	10s

If communication with plant controller or network operator interrupted over 1min, the reactive power maintains the last set-point received.

d. Fixed cosφ

Fixed cosφ			
Parameter	Setting range	Setting step	Default value
Displacement factor Power Factor	0.80ue...0.80oe	0.005	1.00
Displacement factor in com loss condition	--	--	last set-point received
Settling time 3Tau	6s...60s	1s	10s

If communication with plant controller or network operator interrupted over 1min, the reactive power maintain the last set-point received.

Declaration of VDE-AR-N 4110

Page 16 of 27

7. Network security management



Network security management			
Parameter	Setting range	Setting step	Default value
Active power	0...1.0Pn	0.01Pn	1.0Pn
Power Gradient	0.33%Pn/s...0.66%Pn/s	0.01%Pn/s	0.5%Pn/s

The permanent active power reduction can be controlled through APP parameter settings, or through 485 communication Modbus RTU. The register address is 3052, input range is 0~11000, transmission coefficient is 0.01, and transmission unit is %Pn.

Interface: RS485

There is single interface for network security management integrated in each unit and only one command from network or third party can be responded a time.

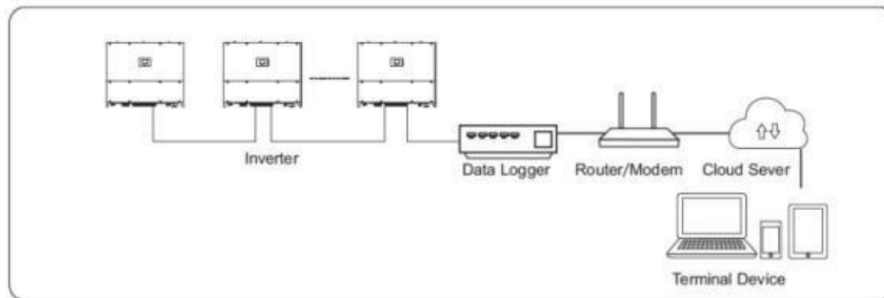

8. Active power output dependent on grid frequency

RoCoF complied with:

±2.0Hz/s for a moving average window 0.5s or

±1.5Hz/s for a moving average window 1s or

±1.25Hz/s for a moving average window 2s P(f) curve:

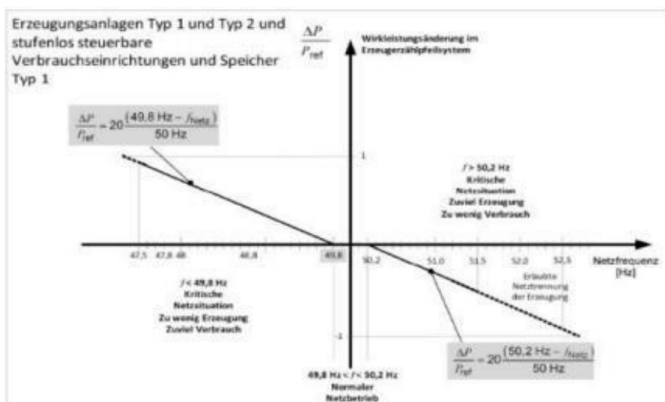

Over frequency curve start point: 50.2Hz - 50.5Hz adjustable Over frequency curve droop: 2% - 12% adjustable.

Declaration of VDE-AR-N 4110

Page 17 of 27

Under frequency curve start point: 49.5Hz - 49.8Hz adjustable Under frequency curve droop: 2% - 12% adjustable.



While frequency step or shift exceeded the dead-band of P(f) curve, the unit output decrease or increase according to the droop of curve. There is no power change when frequency located within the dead-band (50±200mHz default). In the case of frequency above 51.5Hz the unit is able to remain connected to grid for another 5s without any power increase.

Even if the mains frequency has regained the tolerance band of 50,0 Hz ±200 mHz after the frequency deviation, a critical network condition shall still be assumed. The transition from "critical network condition" to "normal operation" is time-limited by a maximum change of the set-point active power, starting from P_{nom}. This set-point active power change (except for the supply of control energy) shall be limited to a maximum gradient of 10 % P_b inst/min. Only when the mains frequency has been within the tolerance band of 50,0 Hz ±200 mHz for an uninterrupted period of 10 min, the normal network operation is considered to be restored and this requirement is no longer valid.

The following requirements complied:

- 1) Initial time delay T_v < 2 s
- 2) Accuracy of frequency measurement < 10 mHz
- 3) Accuracy of fast frequency measurement < 50 mHz
- 4) Sample time < 200 ms



Declaration of VDE-AR-N 4110

Page 18 of 27

9. Quasi-steady-state operation:

During quasi-steady-state operation, the inverter could be able to operate linked to the distribution network in compliance with the minimum time requirements given in Figure 4 over the full frequency range of 47,5 Hz to 51,5 Hz and for voltages in the range of 85 % U_c to 115 % U_c (r.m.s. values of the phase-to-phase voltage) at the network connection point.

The inverter could be able to operate the full frequency range of 47,5 Hz to 51,5 Hz and for voltages in the range of 85 % U_c to 115 % U_c . (For model S6-GC125K-HV)

The inverter could be able to operate the full frequency range of 47,5 Hz to 51,5 Hz and for voltages in the range of 85 % U_n to 115 % U_n . (For models S6-GC80K, S6-GC100K, S6-GC110K, S6-GC125K)

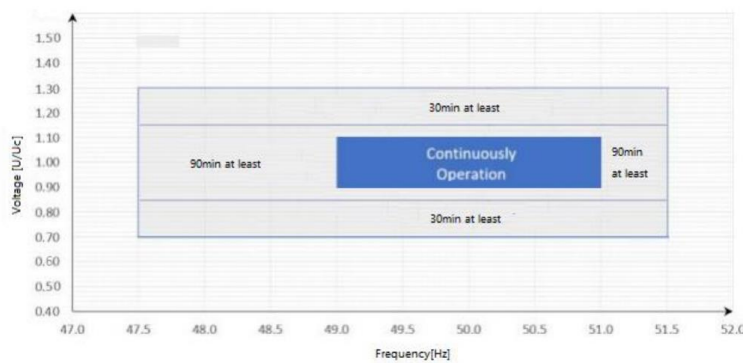

For model S6-GC125K-HV

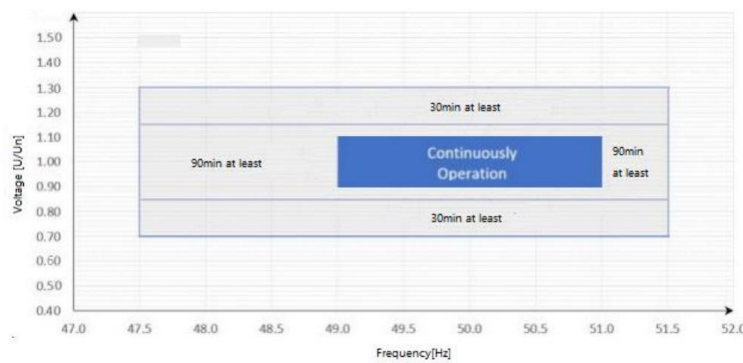

For models S6-GC80K, S6-GC100K, S6-GC110K, S6-GC125K

Declaration of VDE-AR-N 4110

Page 19 of 27



10. Active power dependent on ambient temperature

Following Power-temp curve applies on all series models:

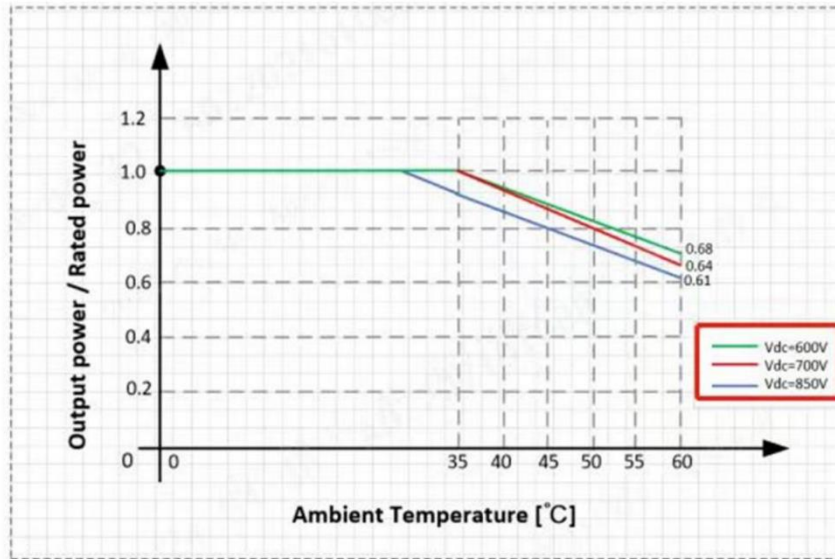

For S6-GC125K

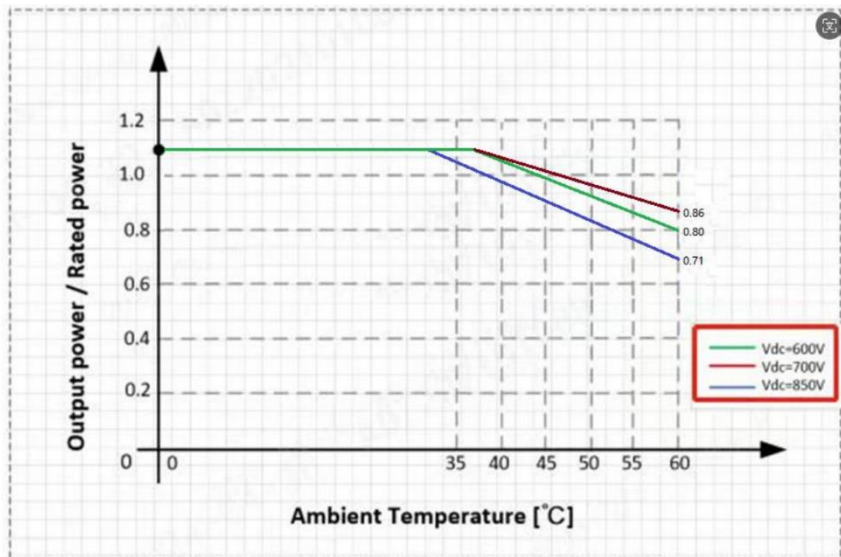

For S6-GC80K, S6-GC100K, S6-GC110K, S6-GC125K-HV

Declaration of VDE-AR-N 4110

Page 20 of 27



11. Interface protection function

Interface protection settings:			
Parameter	Setting range	Setting step	Default value
OV1 protection value OV-G-V1	1.00Un...1.30Un	0.001Un	1.10Un
OV1 protection time OVGV1-T	0.02s...180s	0.02s	100ms
OV2 protection value OV-G-V2	1.00Un...1.30Un	0.001Un	1.25Un
OV2 protection time OVGV2-T	20ms...100ms	0.02s	100ms
UV1 protection value UN-G-V1	0.10Un...1.00Un	0.001Un	0.80Un
UV1 protection time UNGV1-T	0.02s...2.4s	0.02s	1.0s
UV2 protection value UN-G-V2	0.10Un...1.00Un	0.001Un	0.45Un
UV2 protection time UNGV2-T	20ms...800ms	0.02s	300ms
OF1 protection value OV-G-F1	50.0Hz...55.0Hz	0.01Hz	51.5Hz
OF1 protection time OVGF1T	0.02s...5s	0.02s	100ms
OF2 protection value OV-G-F2	50.0Hz...55.0Hz	0.01Hz	52.5Hz
OF2 protection time OVGF2T	20ms...100ms	0.02s	100ms
UF1 protection value UN-G-F1	45.0Hz...50.0Hz	0.01Hz	47.5Hz
UF1 protection time UNGF1T	20ms...100ms	0.02s	100ms

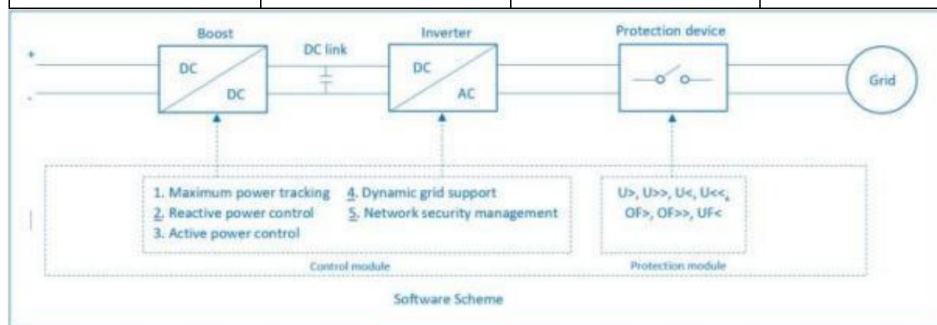

All the settings values are readable through PC or directly on display.

The self-check function of protection device is integrated in unit and could be started by PC without any wiring change. When self-check function started, the program would change the voltage sampling value to trip the protection settings. It's detected by unit if the protection relay works normally.

The integrated protection functions are implemented in separate software modules, and they operate independent from control functions as the software block diagram below:

The auxiliary power supply of protection device be supply from dc side, as a network independent auxiliary power can supply to the protection device over 5s. The protection device would be tripped immediately as long as the auxiliary power supply failed.

Declaration of VDE-AR-N 4110

Page 21 of 27



12. Connection and reconnection conditions

It shall be set out in the unit certificate that the requirements for connection and reconnection of the power generating unit given in 10.4 can be complied with. Based on a manufacturer declaration or on measurements carried out on the power generating unit or on the control unit relevant for analysis of the connection conditions, it shall be verified that connection is possible in the range from 90% Un and 110% Un and frequency in the range from 47.5 Hz and at 50.2 Hz (For models S6-GC80K, S6-GC100K, S6-GC110K, S6-GC125K), 90% Uc and 110% Uc and frequency in the range from 47.5 Hz and at 50.2 Hz (For model S6-GC125K-HV). This time period shall be adjustable from undelayed operation up to 10 min.

After a power generating unit was disconnected from the network by opening the coupler circuit-breaker(galvanic isolation) at the power generating unit due to the tripping of decoupling protection equipment(overfrequency, underfrequency, voltage reduction, voltage rise), automatic connection or reconnection of the power generating units is permitted only if the voltage at the network connection point is at least 95 % Uc and if the frequency is between 49,9 Hz and 50,1 Hz.

The gradient of power recovery could be set between 1%Pn/min – 100%Pn/min.

Automatic reconnection of the power generating units may only be made after the mains voltage and frequency have been stable within the aforementioned voltage and frequency limits for a settable period of time. This time period shall be adjustable from undelayed operation up to 10 min. Unless otherwise specified by the network operator, a default value of 5 min shall be set.

13. Interface Switch Information

Mfg.	Type	Parameter
Hongfa	HF167F-200	200A, -40~85°C
Zettler	AZSR1200	200A, -40~85°C

the interface switch complied with:

- Three-pole galvanic separation.
- The switch is designed as specified by the manufacturer. The switching capacity of the coupling switch may sustain the max. output current of inverter.
- The coupling switch is designed to be triggered without delay.
- The sum of time elements of the protection and switching equipment does not exceed 100 ms.

Declaration of VDE-AR-N 4110

Page 22 of 27



14. Dynamic Grid Support

The inverter is able to keep connecting on the grid in case grid voltage change within the limit curve below, even the step change of voltage exceeded 15%Un.

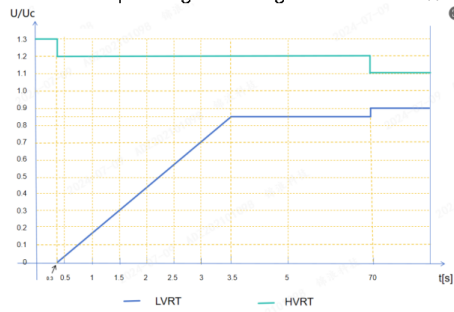

For model S6-GC125K-HV

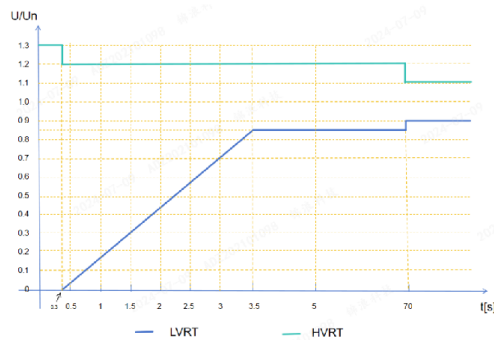

For models S6-GC80K, S6-GC100K, S6-GC110K, S6-GC125K

During the voltage fault, the inverter may:

- a) cease feeding any current to grid or
- b) feed the reactive current of both positive and negative sequence components according to the ΔU - ΔI relationship below:



Bild 15 - Prinzip der Spannungsstützung bei Netzfehlern

Response the reactive current fulfill:

- a) Anschlagzeit: $T_{an,90\%} \leq 30$ ms;
- b) Einschwingzeit: $T_{ein,\Delta x} \leq 60$ ms.

Declaration of VDE-AR-N 4110

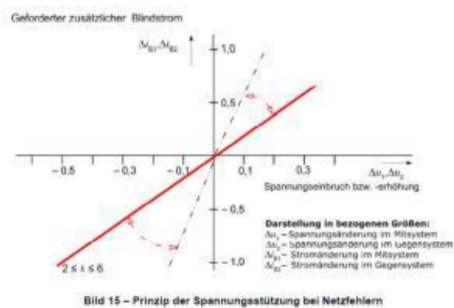
Page 23 of 27



Dynamic network support			
Parameter	Setting range	Setting step	Default value
Operation Mode	Full support / Zero current	--	Full support
K factor VRT_K1, VRT_K2 (*)	2 ...6	0.5	4
Entry threshold StaticVL, StaticVH	Upper bond: 0.8...1.0Un StaticVH Lower bond: 1.0...1.2Un StaticVL	0.01Un	Upper bond: 1.1Un StaticVH Lower bond: 0.9Un StaticVL

Note: (*) K1 is the K factor for positive sequence, K2 is the K factor for negative sequence.

Declaration of VDE-AR-N 4110

Page 24 of 27



15. Multiple faults

Per control strategy of inverter, the PV input power reduced meanwhile in case the power output is blocked during voltage dips. Thus, the primary available energy is able to completely dissipate during the fault.

For instance, in multiple faults test procedure below under P_{Emax} power condition, the dissipated energy can be estimated by $P_{Emax} \cdot (0.16s + 0.6s + 1.05s + 0.16s + 1.05s) = P_{Emax} \cdot 3.02s$

Netzereignis	Residualspannung bezogen auf U_{1min}	Dauer [ms]	Pausenzeit
Doppelfehler	$\leq 0,3$	140 ms – 160 ms	0,3 s – 2 s
	$\leq 0,3$	550 ms – 600 ms	20 s – 30 s
Standardfehler	$\leq 0,3$	950 ms – 1050 ms	20 s – 30 s
Doppelfehler	$\leq 0,3$	140 ms – 160 ms	0,3 s – 2 s
	$\leq 0,3$	950 ms – 1050 ms	

Declaration of VDE-AR-N 4110

Page 25 of 27

**16. Configuration**

Interface protection settings:			
Parameter	Setting range	Setting step	Default value
OV1 protection value OV-G-V1	1.00Un...1.30Un	0.001Un	1.10Un
OV1 protection time OVGV1-T	0.02s...180s	0.02s	100ms
OV2 protection value OV-G-V2	1.00Un...1.30Un	0.001Un	1.25Un
OV2 protection time OVGV2-T	20ms...100ms	0.02s	100ms
UV1 protection value UN-G-V1	0.10Un...1.00Un	0.001Un	0.80Un
UV1 protection time UNGV1-T	0.02s...2.4s	0.02s	1.0s
UV2 protection value UN-G-V2	0.10Un...1.00Un	0.001Un	0.45Un
UV2 protection time UNGV2-T	20ms...800ms	0.02s	300ms
OF1 protection value OV-G-F1	50.0Hz...55.0Hz	0.01Hz	51.5Hz
OF1 protection time OVGF1T	0.02s...5s	0.02s	100ms
OF2 protection value OV-G-F2	50.0Hz...55.0Hz	0.01Hz	52.5Hz
OF2 protection time OVGF2T	20ms...100ms	0.02s	100ms
UF1 protection value UN-G-F1	45.0Hz...50.0Hz	0.01Hz	47.5Hz
UF1 protection time UNGF1T	20ms...100ms	0.02s	100ms
Self-protection settings:			
Parameter	Setting range	Setting step	Default value
OV protection value	--	--	1.40Un
OV protection time	--	--	50ms
Connection condition settings:			
Parameter	Setting range	Setting step	Default value
Voltage range Start-VH, Start-VL	--	--	90%Un...110%Un
Frequency range Start-FH, Start-FL	--	--	47.5Hz...50.2Hz
Delay time Startup-T	--	--	60s
Power Gradient Ramp-up-EN	0.33%Pn/s...0.66%Pn/s	0.01%Pn/s	0.5%Pn/s
Reconnection condition settings:			
Parameter	Setting range	Setting step	Default value
Voltage range Restore-VH, Restore-VL	--	--	≥ 95%Un
Frequency range Restore-FH, Restore-FL	--	--	49.9Hz...50.1Hz
Delay time Restore-T	0...30 mins	1s	10 mins
Power Gradient Reconnect-EN	0.33%Pn/s...0.66%Pn/s	0.01%Pn/s	0.5%Pn/s

Declaration of VDE-AR-N 4110

Page 26 of 27



Reactive power-voltage character curve Q(U):			
Parameter	Setting range	Setting step	Default value
Reactive power node (Q1-Q4)	Q1: 0...0.6Pn Q2: -0.6Pn...0.6Pn Q3: -0.6Pn...0.6Pn Q4: -0.6Pn...0	0.01Pn	Q1: 0.44Pn Q2: 0 Q3: 0 Q4: -0.44Pn
Voltage node (Voltage1- Voltage4)	Voltage1: 0.93Un...1.00Un Voltage2: 0.95Un...1.00Un Voltage3: 1.00Un...1.05Un Voltage4: 1.00Un...1.07Un	0.01Un	Voltage1: 0.96Un Voltage2: 1.00Un Voltage3: 1.00Un Voltage4: 1.04Un
Settling time 3Tau	6s...60s	1s	10s
Character curve Q(P)			
Parameter	Setting range	Setting step	Default value
Reactive Power Node (Q1-Q5)	Q1: -0.6Pn...0.6Pn Q2: -0.6Pn...0.6Pn Q3: -0.6Pn...0.6Pn Q4: -0.6Pn...0.6Pn Q5: -0.6Pn...0.6Pn	0.01Pn	Q1: 0 Q2: 0 Q3: -0.05Pn Q4: -0.33Pn Q5: -0.33Pn
Active Power Node (P1-P5)	P1: 0...1.0Pn P2: 0...1.0Pn P3: 0...1.0Pn P4: 0...1.0Pn P5: 0...1.0Pn	0.1Pn	P1: 0 P2: 0.5Pn P3: 0.6Pn P4: 0.9Pn P5: 1.0Pn
Settling time 3Tau	6s...60s	1s	10s
Fixed Q			
Parameter	Setting range	Setting step	Default value
Reactive power Q React. Power	-0.6Pn...0.6Pn	0.01Pn	Q=0
Reactive power Q in com loss condition	--	--	last set-point received
Settling time 3Tau	6s...60s	1s	10s
Fixed cosφ			
Parameter	Setting range	Setting step	Default value
Displacement factor Power Factor	0.80ue...0.80oe	0.005	1.00
Displacement factor in com loss condition	--	--	last set-point received
Settling time 3Tau	6s...60s	1s	10s
Network security management			
Parameter	Setting range	Setting step	Default value
Active power	0...1.0Pn	0.01Pn	1.0Pn
Power Gradient	0.33%Pn/s...0.66%Pn/s	0.01%Pn/s	0.5%Pn/s
Modbus RTU address			
Parameter	Setting range	Setting step	Default value
3052	0...11000	1	11000
3157	1000...10000	1	3000
Active power output dependent on grid frequency			
Parameter	Setting range	Setting step	Default value
OF threshold OV-F-Start	50.2Hz...50.5Hz	0.01Hz	50.2Hz

Declaration of VDE-AR-N 4110

Page 27 of 27



OF droop Gradient	2%...12%	1%	5%
UF threshold FDStart	49.5Hz...49.8Hz	0.01Hz	49.8Hz
UF droop FDDroop	2%...12%	1%	5%
Dynamic network support			
Parameter	Setting range	Setting step	Default value
Operation Mode	Full support / Zero current	--	Full support
K factor VRT_K1, VRT_K2 (*)	2 ...6	0.5	4
Entry threshold StaticVL, StaticVH	Upper bond: 0.8...1.0Un StaticVH Lower bond: 1.0...1.2Un StaticVL	0.01Un	Upper bond: 1.1Un StaticVH Lower bond: 0.9Un StaticVL

Note: Q(U), Q(P) and Fixed Q working modes can be only set the internal percent parameter Q/Pn.
(*) K1 is the K factor for positive sequence, K2 is the K factor for negative sequence.

17. Short-circuited current of PGU

Type of power generating Unit	Information	Symbol	Value
PGU with full-scale converters	RMS value of the source current for three-phase fault	iskPF	1.00 In
	RMS value of the source current for two-phase fault	I(1)sk2PF	1.00 In
	RMS value of the source current for single-phase fault	I(1)sk1PF	1.00 In
	Negative-sequence short-circuit impedance for integer k-factors	Z(2)PF	0.50 Ohm

The PGU have been designed so that the requirements of VDE-AR-N 4110 for the power generating unit can be complied with.

The prototype is an essential technical advancement or innovation. This product has not been certified and has not been commissioned in Germany.

This product is different to already existing or certified products.

- End -