



# User Manual

Residential Split Phase  
Low Voltage Hybrid  
Energy Storage Inverter



## Applicable Models:

S6-EH2P10K03-SV-YD-L  
S6-EH2P12K03-SV-YD-L  
S6-EH2P14K03-SV-YD-L  
S6-EH2P16K03-SV-YD-L  
S6-EH2P18K03-SV-YD-L

# Important Notes

---

- Product specifications are subject to change without notice. Every attempt has been made to make this document complete, accurate and up-to-date. Individuals reviewing this document and installers or service personnel are cautioned, however, that Solis reserves the right to make changes without notice and shall not be responsible for any damages, including indirect, incidental or consequential damages caused by reliance on the material presented including, but not limited to, omissions, typographical errors, arithmetical errors or listing errors in the material provided in this document.
- Solis accepts no liability for customers' failure to comply with the instructions for correct installation and will not be held responsible for upstream or downstream systems Solis equipment has supplied.
- The customer is fully liable for any modifications made to the system; therefore, any hardware or software modification, manipulation, or alteration not expressly approved by the manufacturer shall result in the immediate cancellation of the warranty.
- Given the countless possible system configurations and installation environments, it is essential to verify adherence to the following:
  - There is sufficient space suitable for housing the equipment.
  - Airborne noise produced depending on the environment.
  - Potential flammability hazards.
- Solis will not be held liable for defects or malfunctions arising from:
  - Improper use of the equipment.
  - Deterioration resulting from transportation or particular environmental conditions.
  - Performing maintenance incorrectly or not at all.
  - Tampering or unsafe repairs.
  - Use or installation by unqualified persons.
- This product contains lethal voltages and should be installed by qualified electrical or service personnel having experience with lethal voltages.

# Table of Contents

**1 Introduction**

**2 Safety**

**3 Overview**

**4 Operating Modes**

**5 Installation**

**6 Commissioning**

**7 Troubleshooting**

**8 Specifications**

**9 Appendix**

# Table of Contents

---

1. Introduction.....	06
1.1 Inverter Description.....	06
1.2 Included Components .....	09
1.3 Tools Required for Installation .....	09
1.4 Inverter Storage .....	10
2. Safety & Warning.....	11
2.1 Safety .....	11
2.2 General Safety Instructions .....	11
2.3 Notice for Use.....	13
2.4 Notice for Disposal .....	13
2.5 Protection Circuitry and Controls.....	13
3. Overview.....	14
3.1 LCD Display Screen & Indicator Lights.....	14
3.2 Inverter Wire Box and Connection Points.....	15
4. Operating Modes.....	16
4.1 PV-Only.....	16
4.2 Energy Storage.....	17
4.3 DC Coupling vs AC Coupling.....	20
4.4 Partial-Home vs Whole-Home Backup.....	22
4.5 Backup Power Inverter Paralleling.....	24
4.6 Generator Operation.....	27
4.7 Wiring Diagrams.....	28
5. Installation.....	31
5.1 Selecting a Location to Install the Inverter.....	31
5.2 Inverter Handling.....	32
5.3 Inverter Dimensions.....	34
5.4 Mounting the Inverter.....	35
5.5 Max. Conductor Sizes & Torque Specs.....	37
5.6 Equipment Grounding & Neutrals.....	38
5.7 PV Cable Installation.....	39
5.8 Battery Installation.....	40
5.9 AC Wiring.....	41
5.10 Generator, AC-Coupling, Load Control.....	46
5.11 Inverter Communication.....	47

# Table of Contents

---

6. Commissioning.....	54
6.1 Pre-Commissioning & Start-Up Procedure.....	54
6.2 Solis Loggers & Third-Party Gateways.....	54
6.3 SolisCloud.....	55
6.4 Configuring the Inverter Settings.....	56
6.5 SolisCloud Bluetooth Tool Settings Tree.....	64
6.6 LCD Screen Settings Tree.....	65
7. Troubleshooting.....	66
7.1 Inverter Shutdown Procedure.....	66
7.2 Inverter Maintenance.....	66
7.3 Inverter Alarm Codes.....	67
7.4 Inverter Firmware.....	72
8. Appendix.....	73
8.1 Default Settings for IEEE1547-2018 (UL-240V-18 Standard).....	73
8.2 Data Collection & Storage.....	75
8.3 Use-Case Scenario Diagrams.....	76

# 1. Introduction

## 1.1 Inverter Description

The Solis Low Voltage (LV) Hybrid series is designed for residential applications. The inverter is capable of pairing with low-voltage (48V) lithium-ion and lead-acid batteries to maximize self-consumption and provide backup power if the grid fails and there is not enough PV power to cover load demand. This inverter can operate in both on-grid and off-grid applications. The S6 hybrid series consists of the following inverter models: 10kw, 12kw, 14kw, 16kw and 18kw.

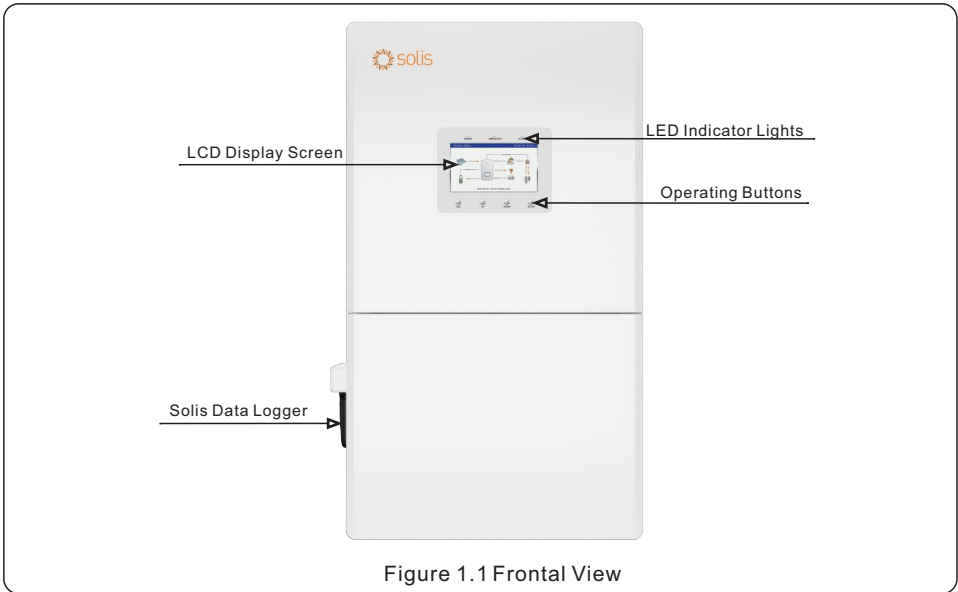

Figure 1.1 Frontal View

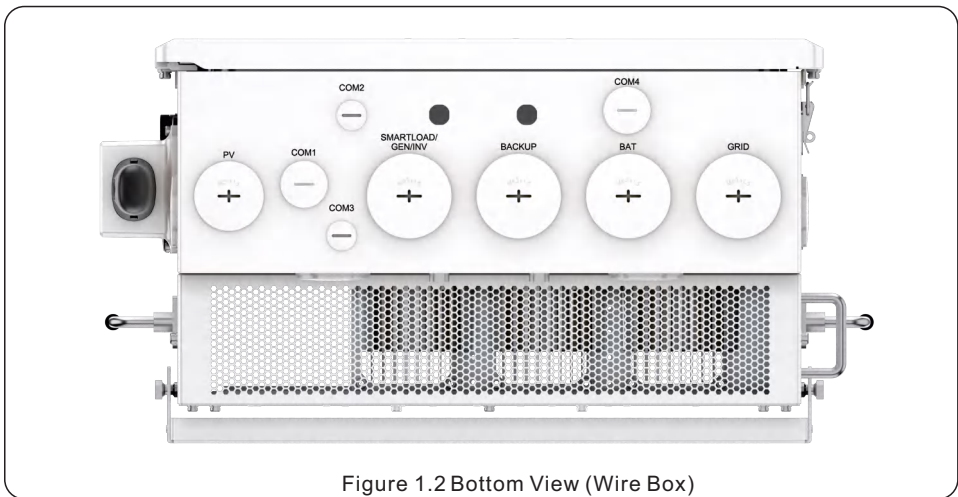

Figure 1.2 Bottom View (Wire Box)

# 1. Introduction

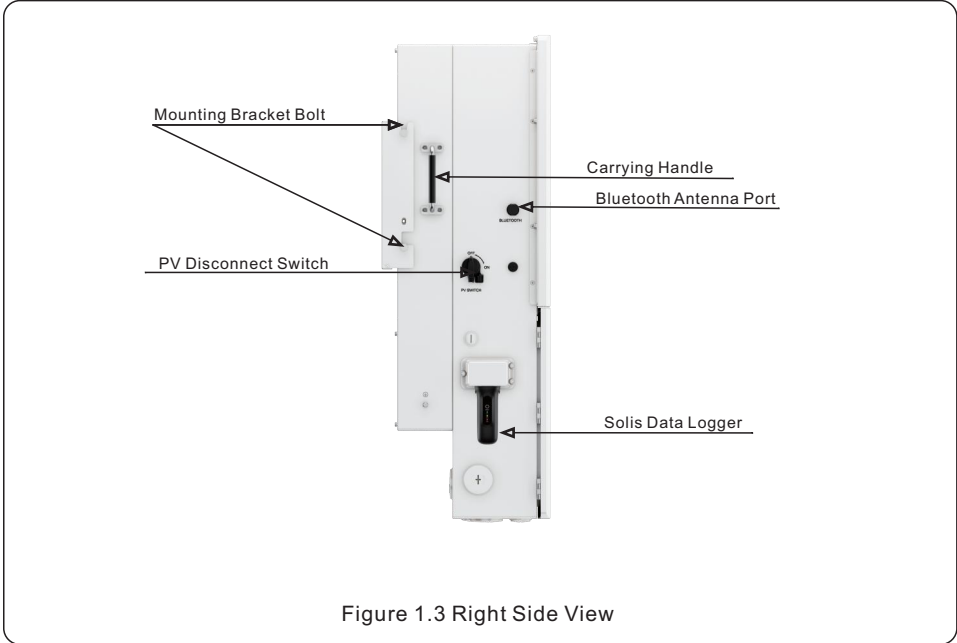

Figure 1.3 Right Side View

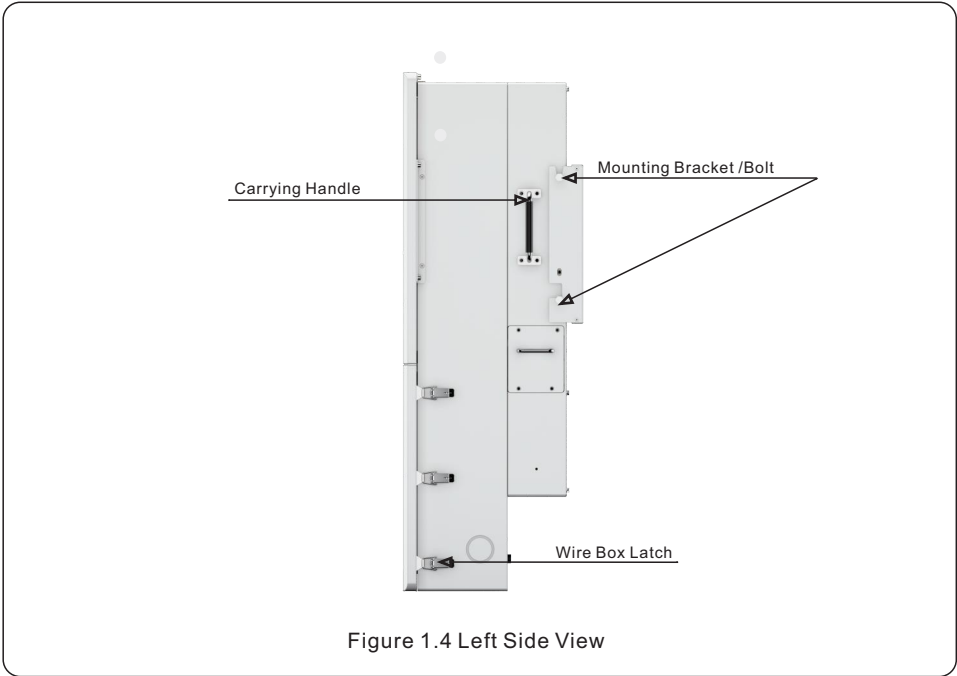

Figure 1.4 Left Side View

# 1. Introduction

---



Figure 1.5 Back View





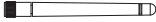

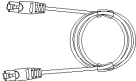

Figure 1.6 Top View













# 1. Introduction

## 1.2 Components Included with the Inverter

If any of these items are missing, please contact your local Solis distributor or the Solis service team.

 <p>Inverter x1</p>	 <p>Inverter Mounting Bracket x1</p>	 <p>M6 Stabilizing Set Bolts x2</p>	 <p>Concrete Anchor Bolts x4</p>	 <p>Data Logger</p>
 <p>Bluetooth Antenna</p>	 <p>Current Transformers x2</p>	 <p>RJ45 Connector x2</p>	 <p>Parallel Communication Cable x1</p>	

## 1.3 Tools Required for Inverter Installation

 <p>Technician Screwdriver</p>	 <p>Torque Wrench Screwdriver</p>	 <p>Wire Strippers 12AWG to 6AWG</p>	 <p>Wire Strippers 20AWG to 10AWG</p>	 <p>Channel Locks</p>
 <p>Multimeter (AC/DC amps)</p>	 <p>Drill and Impact Driver</p>	 <p>Ratcheting Crimper</p>	 <p>Bubble Level</p>	 <p>Smartphone (for commissioning)</p>
 <p>5mm/8mm Hex Tip</p>	 <p>Radial Cable Stripper</p>			

# 1. Introduction

---

## 1.4 Inverter Storage

- If the inverter is not installed immediately, please abide by the storage instructions and environmental conditions listed below.
- Use the original box to repackage the inverter, seal with adhesive tape with the desiccant inside the box.
- Store the inverter in a clean and dry place, free of dust and dirt. The storage temperature must be between -40~158°F and humidity should range from 0 to 100% (non-condensing).
- Do not stack more than two (2) inverters high on a single pallet. Do not stack more than 2 pallets high.
- Keep the box(es) away from corrosive materials to avoid damage to the inverter enclosure.
- Inspect the packaging regularly. If packaging is damaged (wet, pest damages, etc.), repackage the inverter immediately.
- Store inverters on a flat, hard surface -- not inclined or upside down.
- Do not remove the desiccant packet that is included with the inverter. It is included to ensure that any residual moisture is absorbed quickly.
- Restarting after a long period of non-use requires the equipment be inspected and, in some cases, the removal of oxidation and dust that has settled inside the equipment will be required.
- Perform an annual visual inspection of the inverter box for signs of damage
- If the inverter has been removed from the box and then replaced, put desiccant packets in the inverter wire box to ensure the internal components stay dry
- Do not store the inverter outside or in a place that does not have environmental controls.



**DO NOT STACK  
MORE THAN 2 HIGH**

## 2. Safety & Warning

### 2.1 Safety

The following types of safety instructions and general information appear in this document as described below:



#### **DANGER**

“Danger” indicates a hazardous situation which if not avoided, will result in death or serious injury.



#### **WARNING**

“Warning” indicates a hazardous situation which, if not avoided, could result in death or serious injury.



#### **CAUTION**

“Caution” indicates a hazardous situation which if not avoided, could result in minor or moderate injury.



#### **NOTE**

“Note” provides tips that are valuable for the optimal operation of your product.



#### **WARNING: Risk of fire**

Despite careful construction, electrical devices can cause fires.

- Do not install the inverter in an area containing flammable materials or gases.
- Do not install the inverter in a potentially explosive atmosphere.

### 2.2 General Safety Instructions



#### **WARNING**

Only devices in compliance with SELV (EN 60950) may be connected to the RS485 and USB interfaces.



#### **WARNING**

Do not connect PV array positive (+) or negative (-) to ground, doing so could cause serious damage to the inverter.



#### **WARNING**

Electrical installations must be done in accordance with local and national electrical safety standards.



#### **WARNING**

Do not touch any internal parts until 5 minutes after disconnection from the utility grid, PV array, and battery.

## 2. Safety & Warning



### **WARNING**

To reduce the risk of fire, over-current protective devices (OCPD) are required for all circuits connected to the inverter.

The DC OCPD shall be installed per local requirements. All photovoltaic source and output circuit conductors shall have isolators that comply with the NEC Article 690, Part II.

All Solis single phase inverters feature an integrated DC disconnect switch.



### **CAUTION**

Risk of electric shock, do not remove the cover. There are no serviceable parts inside, refer servicing to qualified and accredited service technicians.



### **CAUTION**

The PV conductors are energized with high voltage DC when the PV modules are exposed to sunlight.



### **CAUTION**

The surface temperature of the inverter can reach up to 75°C (167°F). To avoid risk of burns, do not touch the surface of the inverter while it is operating. The inverter must be installed out of direct sunlight exposure.



### **NOTE**

PV modules used with inverter must have an IEC 61730 Class A rating.



### **WARNING**

Operations must be accomplished by a licensed electrician or a person authorized by Solis.



### **WARNING**

Installer must wear personal protective equipment during the entire installation process in case of electrical hazards.



### **WARNING**

The AC Backup Port of the inverter cannot be connected to the grid. Only the AC Grid Port may be connected to the grid.



### **WARNING**

Please refer to the product manual of the battery before installation and configuration to the inverter.



**Systems using this product shall be designed and built in accordance with the NEC & local electrical codes & standards.**

## 2. Safety & Warning

---

### 2.3 Notice for Use

The inverter has been constructed according to the applicable safety and technical guidelines. Use the inverter in installations that meet the following specifications only:

1. Permanent installation is required.
2. The electrical installation must be compliant with all local and national regulations & standards.
3. The inverter must be installed according to the instructions stated in this manual.
4. The inverter must be installed according to the inverter technical specifications.

### 2.4 Notice for Disposal

This product shall not be disposed of with household waste. It must be segregated and brought to an appropriate disposal facility to ensure proper recycling.

This is to be done in order to avoid negative impacts on the environment and human health. The inverter contains materials that should not end up in a landfill.

Local waste management rules shall be observed and respected.

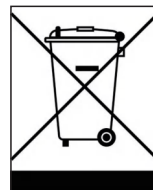

### 2.5 Protection Circuitry and Controls

To meet relevant codes and standards, the Solis U.S. single phase inverter line is equipped with protective circuitry and controls. These include Arc Fault Circuit Interrupter (AFCI) & Anti-Islanding Protection.

#### **Arc Fault Circuit Interrupter AFCI:**

Edition 2011 of the National Electrical Code®, Section 690.11, requires that all PV plants attached to a building are fitted with a means of detecting and interrupting serial electric arcs in the PV wiring and array. An electric arc with a power of 300W or greater must be interrupted by the AFCI in the time specified by UL 1699B. After five arc fault detections in 24 hours, an AFCI-induced shutdown will be triggered. If this event occurs, the inverter must be manually reset. After clearing the source of the fault, the inverter can be powered back on and allowed to resume normal operation.

#### **Anti-Islanding Protection:**

Anti-Islanding is a condition where the inverter ceases to produce power when the grid is not present. Circuitry, along with firmware, has been designed to determine if the grid is present by adjusting the output frequency of the inverter. In the case of a 60Hz resonant system where the inverter is partially isolated from the grid, the inverter programming can detect if there is a resonant condition or if the grid is actually present. It can also differentiate between inverters operating in parallel and the grid.



#### **NOTE:**

All Solis inverters come with AFCI and Anti-Islanding protections integrated and enabled by default. The settings cannot be disabled or modified.

# 3. Overview

## 3.1 LCD Display Screen and Indicator Lights

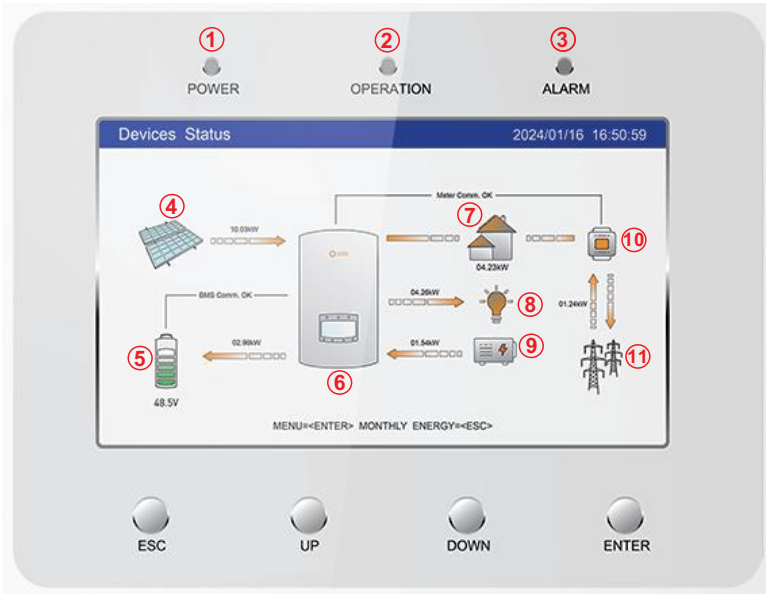

#	Name	Description
1	Power LED	This LED is always red when the inverter has adequate AC or DC voltage. This LED does not indicate any problems.
2	Operation LED	This LED is always green when the inverter is operating normally and producing AC power.
3	Alarm LED	This LED will light up yellow or red any time the inverter has an alarm code.
4	PV Icon	Represents PV power being generated in DC kW.
5	Battery Icon	Represents the battery connected to the inverter charging and discharging in DC kW and state-of-charge (SOC)
6	Inverter Icon	Represents the Solis hybrid inverter in the system.
7	Home Icon	Represents the cumulative grid-side home load consumption & power being exported to or imported from the grid in AC kW.
8	Backup Icon	Represents home load consumption on the backup-side of the system in AC kW.
9	Generator Icon	Represents generator power being produced in AC kW. Only appears when the generator is on and grid is off.
10	Meter/CT Icon	Represents the energy meter/CT monitoring the consumption power & import/export power to/from the grid in AC kW.
11	Grid Icon	Represents the grid and power being imported from/exported to the utility (grid) in AC kW.

# 3. Overview

## 3.2 Inverter Wire Box and Connection Points

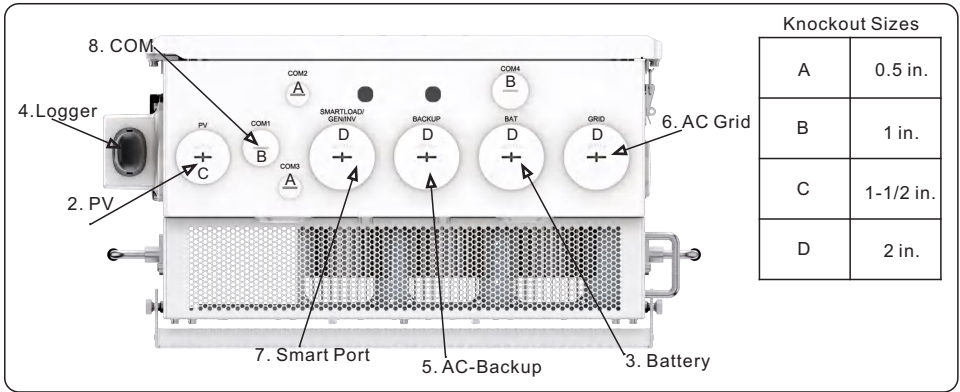

Name	Description
1. PV	Conduit and PV conductors should be connected here
2. Battery	Conduit for battery conductors should be connected here
3. Solis Logger Port	Port (USB) for connecting Solis data loggers only
4. AC-Backup	Conduit for AC conductors to backup loads panel should be connected here
5. AC-Grid	Conduit for AC conductors to the main service panel should be connected here
6. Smart Port	Conduit for AC conductors to a generator, AC-coupled PV system, or sheddable load
7. Communication (COM)	RS485 & CAN communication cables should use these knockouts/terminals
8. Battery Breaker	Breaker for the battery, only included with the inverter if ordered that way
9. Neutral Bus Bar	Common bus bar for all neutral conductors to terminate (not grounded)
10. Ground Bus Bar	Common bus bar for all ground conductors to terminate - For AC

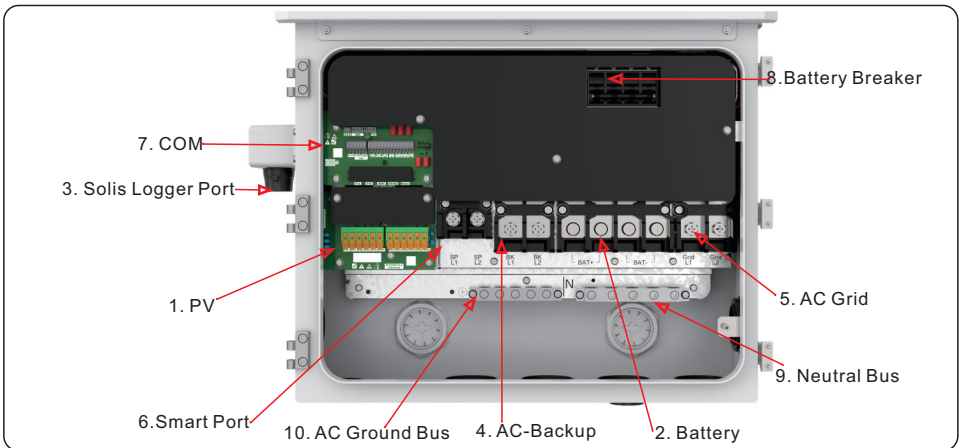

# 4. Operating Modes

## 4.1 PV-Only

### 4.1.1 Grid-Tie PV String Inverter

This inverter can be used as a PV-only grid-tied string inverter. Only the PV and grid ports would be utilized. Whenever the grid fails the inverter will shut down. The inverter does have a feature allowing it to provide backup power with only PV. However, an overload condition will occur if load consumption exceeds the available power from the PV. This feature is great for short-duration (1-2) hour outages during the day with load consumption kept low. Batteries can always be added in the future, keeping the initial installation cost low. Only single-inverter applications can support this feature. Overload faults occurrences and recover times are as follows: First - 30 seconds, Second - 3 minutes, Third, Fourth, and Fifth - 10 minutes, Sixth - hard reset is required, no automatic recovery.

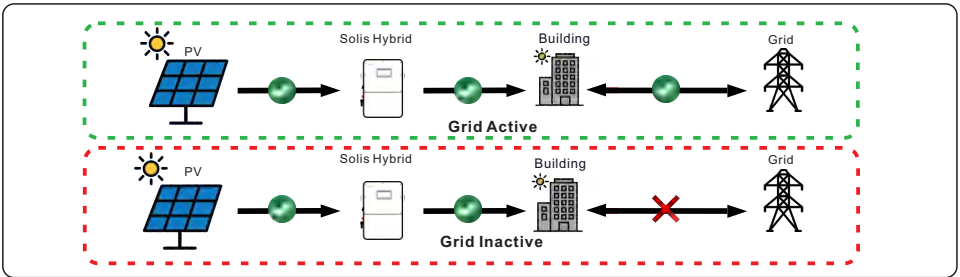

### 4.1.2 Export Power Control

The inverter offers the ability to manage export power. During the system commissioning process, export power control can be enabled. An export power limitation can then be set to the desired kW value. The inverter will then regulate how much power gets sold back to the utility company.

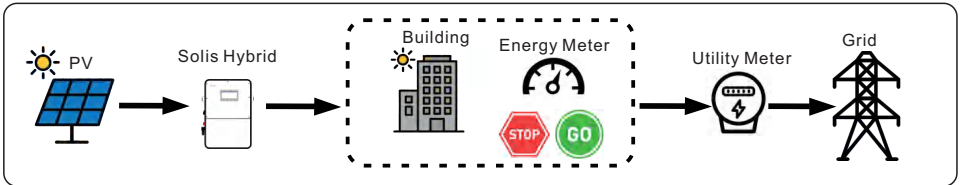

Each Solis hybrid comes with a pair of split-core CTs, which gets installed externally to the inverter at the point of utility power connection to the home. The CTs measure the power being consumed, imported, and exported by the home. The hybrid uses the data from these CTs to determine whether or not it needs to curtail the PV power to meet the set export power limitation. Export power control can be enabled with or without a battery being installed.

### Limited Export Power and Changes in Consumption

There is an export power limit in kW that can be configured. When there are changes in home energy consumption, there is a reaction time of a few seconds where the inverter may need to either curtail PV or discharge power to maintain the export limit.

#### NOTE:



Solis export power control function is based on the measurements taken by the provided CTs or an external energy meter. Due to the sampling interval limitation, when there are sudden changes in load consumption small amounts of power will be exported. For stricter export control applications, it is recommended to set the export power limit to a negative value, such as -300 watts.

# 4. Operating Modes

## 4.2 Energy Storage

### 4.2.1 Overview of Energy Storage Modes

The S6 hybrid is capable of providing AC power to home loads using PV and battery power in the event of a grid failure. This is known as **backup power**. The amount of backup power that each S6 hybrid model can provide is equal to the amount of on-grid power that it can provide. For example, the 16K model can provide up to 16kW of continuous backup power even when the grid is absent.

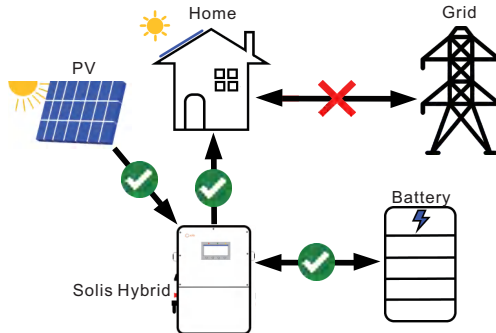

Figure 4.3 Backup power with Solis S6 hybrid

If the primary purpose of the energy storage system is to store as much of the PV power as possible so that it can be used later to offset the consumption of grid power, this is known as energy arbitrage. *Time-of-use*, *self-consumption*, and *peak-shaving* are all examples of **energy arbitrage**. Typically, the battery will cycle daily as it charges with PV during the day and then discharges in the evening to cover home load demand and minimize the amount of grid power imported from the utility company.

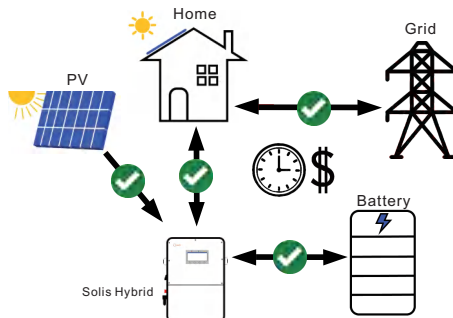

Figure 4.4 Energy arbitrage with Solis S6 hybrid

This Solis hybrid can also operate in an entirely remote system where there is no grid present at all. This is called **off-grid** mode. It is very similar to backup in that the inverter will supply AC power to loads with PV and battery power only. However, backup mode is only for grid-connected systems.



**NOTE:**

The inverter is able to provide off-grid/backup power with only PV and no battery. However, the load consumption must remain less than the available PV power or else an overload fault will occur and the system will shut down for five minutes.

# 4. Operating Modes

## 4.2.2 Energy Arbitrage

The S6 hybrid inverter has multiple operating modes that can be programmed so that the performance of the system is tailored to the specific needs of each individual system owner. The backup power function of the inverter can be enabled or disabled independently of the energy arbitrage modes: (1) Self-Use (2) Selling first (3) Off grid (4) Peak-Shaving (Professional Setting)

### Self-Use Mode (Self-Consumption)

Self-Use is the default energy storage mode. PV power will always supply the home loads first. Any excess PV power gets stored in the battery. If the battery is fully charged, the remaining power can be exported if the system is configured to allow it. If not, the PV power will be curtailed.

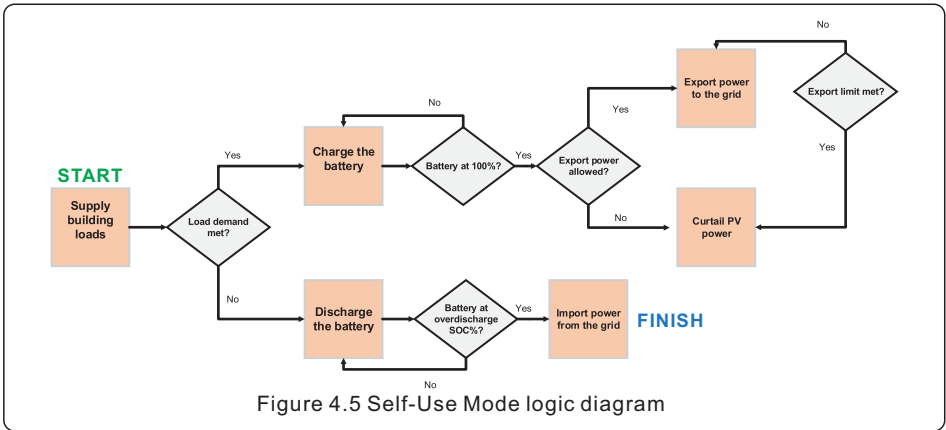

### Selling First Mode (Export Priority)

This mode can be thought of as export priority mode. The system will first supply the home loads with PV power and then it will seek to export the excess PV power, up to the set limit. Once the limit is reached, the remaining power will be stored in the battery. If the battery is fully charged, the PV will at that point be curtailed. This mode is for those who receive an equal rate for power exported or who have a much higher ratio of PV power generated to power consumed and are using the battery primarily for backup instead of energy arbitrage daily cycling.

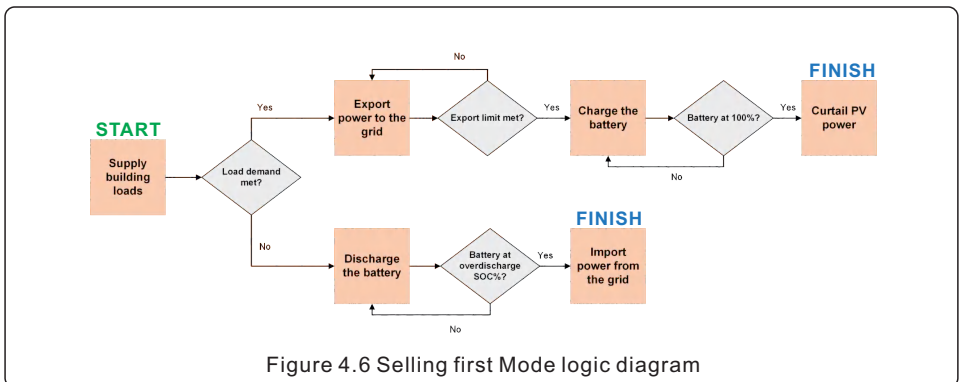

# 4. Operating Modes

## Off-Grid Mode

There is a dedicated mode specifically for off-grid remote systems that are not electrically connected to the grid at all, such as a cabin in the woods. This mode is not to be confused with backup, which occurs only for grid-tied systems. The logic for Off-Grid mode is the same as Self-Use mode. However, there is no export power control and a generator is often used in place of the grid to supplement the PV & batteries. The inverter will use generator power to supply the loads and recharge the battery. For single inverter systems, it is recommended to have a battery connected to the inverter. For parallel system ( $\geq 2$  inverters), the inverters must have batteries connected in order to provide power in an off-grid system. The inverter cannot operate in an off-grid system with PV only for parallel systems. The logic diagram below assumed a generator is connected. However, if there is no generator, then once the battery discharges to the Overdischarge SOC%, the home loads will lose power. The inverter will start back up once there is PV the next day.

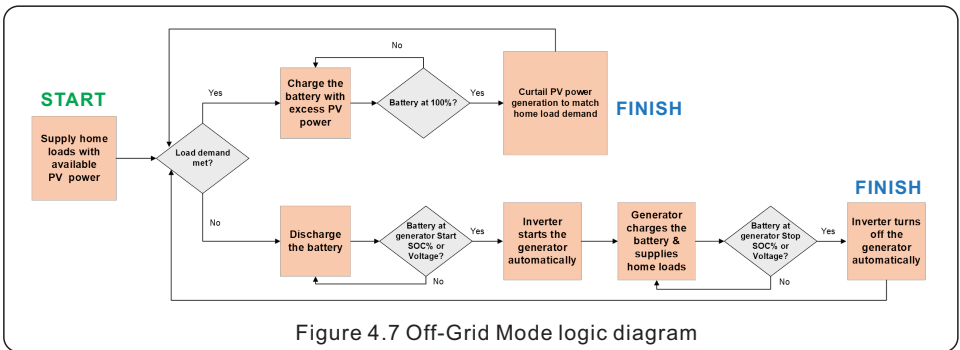

Figure 4.7 Off-Grid Mode logic diagram



### NOTE:

To utilize off-grid mode, the inverter must not be connected to the grid at all. Only conductors from the generator can be connected to the grid port when off-grid mode is used.

## Peak-Shaving Mode

Peak-shaving mode is ideal for those who pay a variable rate for energy based on the amount of consumed power (kW). This mode limits the power imported from the grid. The inverter will only discharge the battery when the power imported from the grid exceeds a specified amount (kW).

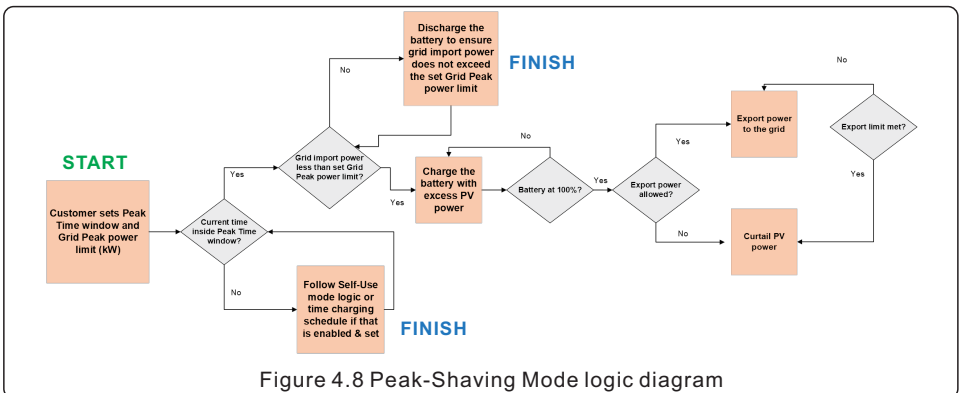

Figure 4.8 Peak-Shaving Mode logic diagram

# 4. Operating Modes

## 4.3 DC Coupling vs AC Coupling

### 4.3.1 DC-Coupling

DC-coupling is the recommended configuration for this inverter. This is because DC-coupling allows the full potential of this inverter to be utilized, maximizing the efficiency of the PV-to-battery charging. In a DC-coupled system, the PV also gets connected to the inverter in addition to the battery. The inverter will charge the battery directly with DC power from the PV. Typically, DC-coupling is done when additional PV is being added or when the system is new and being installed with energy storage.

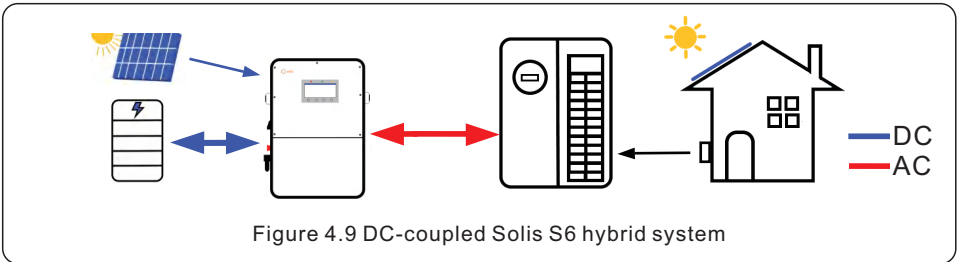

Figure 4.9 DC-coupled Solis S6 hybrid system

The next section explains how the S6 hybrid can be AC-coupled. The next several sections following it will all focus on DC-coupling methods.

### 4.3.2 AC-Coupling on the Grid Side

The Solis S6 hybrid can be DC-coupled or AC-coupled to a home to add energy storage. In an AC-coupled the energy storage is connected to the AC-side of the system. Typically, the battery and Solis hybrid pairing get connected in parallel with an existing PV system. The Solis hybrid will charge the battery with power from the existing PV system. However, doing so requires an AC to DC conversion since the PV power goes to the Solis hybrid as AC power. When AC-coupling with the Solis hybrid, additional PV can be added and connected to the Solis hybrid, but it is not required. The Solis hybrid would just need to be installed with a compatible low voltage battery and then be connected to the home load center in parallel with the existing PV system.

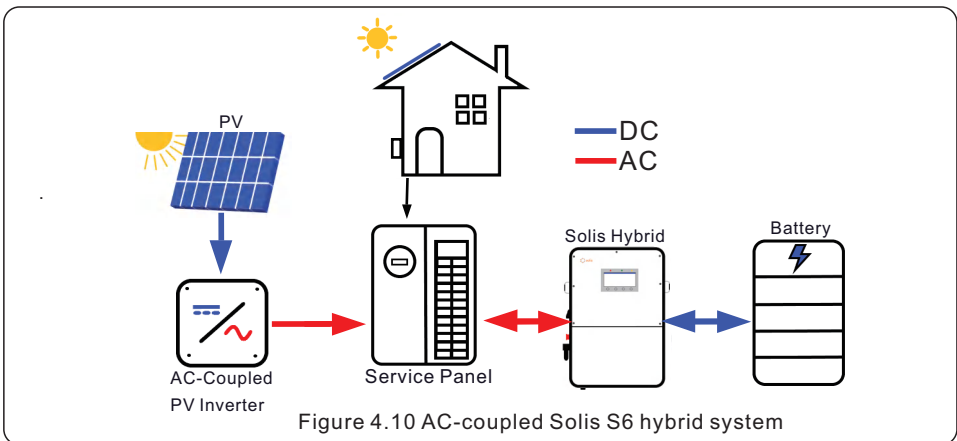

Figure 4.10 AC-coupled Solis S6 hybrid system

The ability to be AC-coupled makes the Solis hybrid ideal for system retrofits. The hybrid can be installed in place of the old PV inverter but with energy storage added to it.

# 4. Operating Modes

## 4.3.3 AC-Coupled Using the Solis Smart Port

To utilize the existing PV system when the grid fails, the existing PV system can be connected to the inverter Smart Port. It should be noted that the AC coupled PV inverter power must be less than or equal to the rated power of the Solis hybrid inverter. The acronym “ACPV” will be used to generically describe any existing PV system that will be AC-coupled with the energy storage and backup. This is to distinguish it from “PV”, which is connected to the DC-side of the Solis hybrid inverter directly. If the load consumption on the grid-side is higher than the inverter nameplate power rating while the grid is present, an overload alarm could occur. This is when the combined PV power going to the loads from both the Solis and the ACPV system exceeds the Solis nameplate power rating. For example, if a 10kW ACPV system is connected to the smart port of a 10kW Solis hybrid inverter, and there is an additional 10kW of PV connected to the PV input of the Solis hybrid inverter, the inverter could trip if more than 10kW of power goes from the inverter to the grid-side loads or is exported to the utility.

The ACPV system connected to the smart port of the system must be smaller than or the same size as the Solis hybrid inverter. Export power must be set so that the maximum export power is equal to the Solis inverter nameplate power rating.

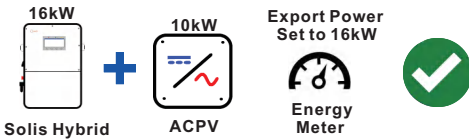

Do not connect an ACPV system to the smart port of the system that is larger than the nameplate power rating of the Solis inverters. If there are multiple Solis inverters, then the combined total power.

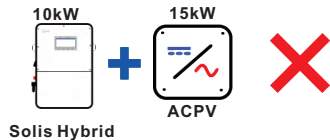

### ON grid

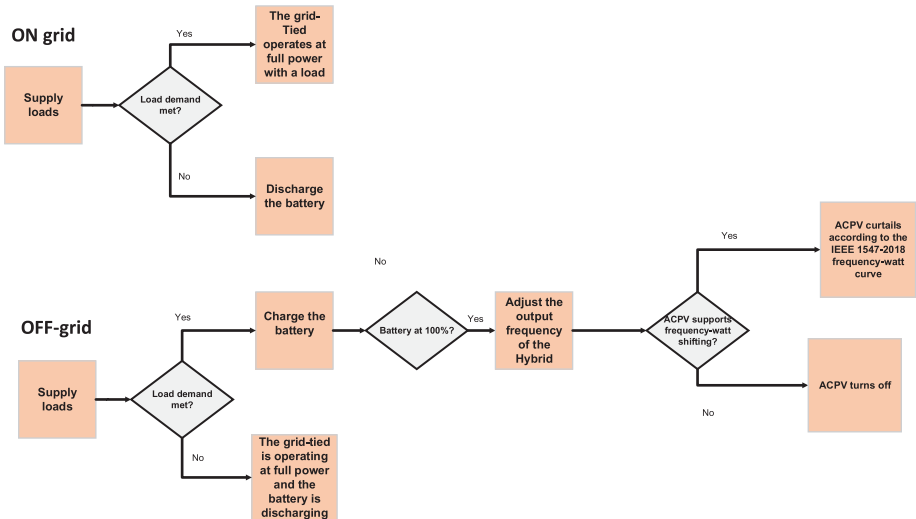

Figure 4.11 AC-Coupling (ACPV) with Backup Operating Logic

# 4. Operating Modes

## 4.4 Partial-Home vs Whole-Home Backup

This inverter is capable of providing AC power to home loads using PV and battery power in the event of a grid failure. When the inverter senses that the grid power has been lost, it automatically opens the relay between itself and the grid. It keeps the relay closed to the backup, allowing it to supply AC power to the home loads as long as power is available. The loads that are to be backed up will need to be located in a load center that is electrically isolated from the utility point-of-connection to ensure that the anti-islanding requirement remains unviolated. The inverter will automatically reconnect to the grid once it senses that power is restored.

The backup output of the inverter has the ability to handle unbalanced loads, with a load power range of 0-50% of the rated output power for each phase. It is recommended to evenly distribute the backup loads between the two phases during system installation. If a single phase load exceeds 50% of the inverter rated power, an overload alarm will trigger, and the inverter will temporarily shut down.

**Note: The backup switch time is < 10 milliseconds.**



**Partial-home backup** systems should only have **light loads** backed up. This ensures that the battery does not deplete too quickly, allowing the PV power generated to balance the load demand. Light loads include lights, TVs, computers, routers, and most things that can plug into an outlet.

**Whole-home backup** systems can have all home loads backed up, including the **heavy loads**. However, enough PV, battery, and (or) generator power must be available to meet the high current demand of the heavy loads. It is recommended to oversize the system for the needs of the owner.

### 4.4.1 Partial-Home Backup

The homeowner will need to be consulted to understand why they are installing a battery. Determine what the maximum amount of continuous power (kW) should be to support their loads. Also, calculate how much energy storage capacity (kWh) they will need to carry them through a power outage. Lastly, you will have to *figure out which loads they want to have backed up and which breakers support those loads*. If they are willing to live with just a few key things such as the fridge, lights, and outlets, this is **partial-home backup**, also known as dedicated loads backup. For this system, the breakers supporting the loads that are to be backed up must be relocated into a load center that will be connected to the backup side of the inverter. These loads will be supported if the grid fails, all of the other loads will not.

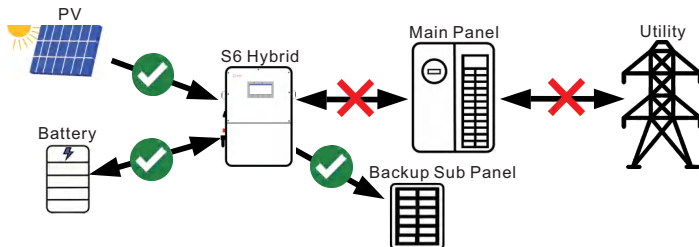

Figure 4.12 Partial-home backup with one S6 hybrid

# 4. Operating Modes

When grid power is lost, the inverter disconnects itself from the grid. It keeps the backup side energized using PV and battery power. When the grid is restored, it reconnects to the grid after a five minute synchronization period. While on-grid, the inverter is capable of passing grid power to the loads whenever there is not enough PV and/or battery power available to support the demand. Multiple units in parallel can increase the amount of available continuous and surge power (kW) to handle loads with more inductance such as air conditioners, heaters, EV chargers, and pumps.

In a partial home backup system, the loads that are to be backed up must be relocated from the main service panel to a new backup sub panel that is connected to the backup side of the inverter. The loads left in the main panel are not backed up when the grid fails.

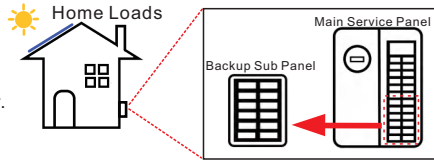

Figure 4.13 Dedicated loads for partial-home backup

### Surge Capacity and Passthrough Power

There will be times when the loads on the backup side require more power than the inverter is able to provide with PV and battery power. Each model of the S6 hybrid inverter is able to pass through **180A** of power from the grid to the loads. The surge capacity depends on which inverter model and how much battery power is installed. Installing multiple inverters in parallel increases the surge capacity.

This chart shows the maximum surge power that each model can support. The surge capacity is 200% of the continuous for 10s.

Ex:  $16\text{kW} \times 200\% = 32\text{kW}$  for 10 seconds

Inverter Model	Maximum Surge PowerBackup (10 seconds)
S6-EH2P10K03-SV-YD-L	20 kW (83.4A)
S6-EH2P12K03-SV-YD-L	24 kW (100A)
S6-EH2P14K03-SV-YD-L	28 kW (116.6A)
S6-EH2P16K03-SV-YD-L	32 kW (133.4A)
S6-EH2P18K03-SV-YD-L	36 kW (150A)

Figure 4.14 Passthrough Power and Surge Capacity

### Frequency Shifting for Controlling AC-Coupled PV in Backup Mode

There is no direct communication between the Solis hybrid inverter and the AC-coupled PV system. The Solis inverter uses frequency-shifting to modulate the output of the ACPV system while in backup mode. The inverter uses the frequency-watt curve outlined in the IEEE 1547-2018 standard. When in backup mode, the Solis hybrid will begin to shift the AC frequency when it detects that the power supplied by all of the PV, including the ACPV, is greater than the power demanded (consumed) and the battery is fully charged. This shift in frequency will be detected by the ACPV system. If the ACPV system also supports the IEEE 1547-2018 frequency-watt curve, then its output power will be reduced according to that curve. If the ACPV system does not support frequency-watt shifting then it will shut off as the frequency shifts. The ACPV will turn back on once the Solis hybrid brings the frequency back to normal.

# 4. Operating Modes

## 4.5 Backup Power Inverter Paralleling

Up to *six* hybrid inverters can be installed together in parallel on the backup side of the system. The backup ports of each inverter would terminate in separate overcurrent protection devices within the backup load center. There is no limit from Solis on the number of inverters that can be paralleled together if they are only being paralleled on the grid-side with no backup capability whatsoever.

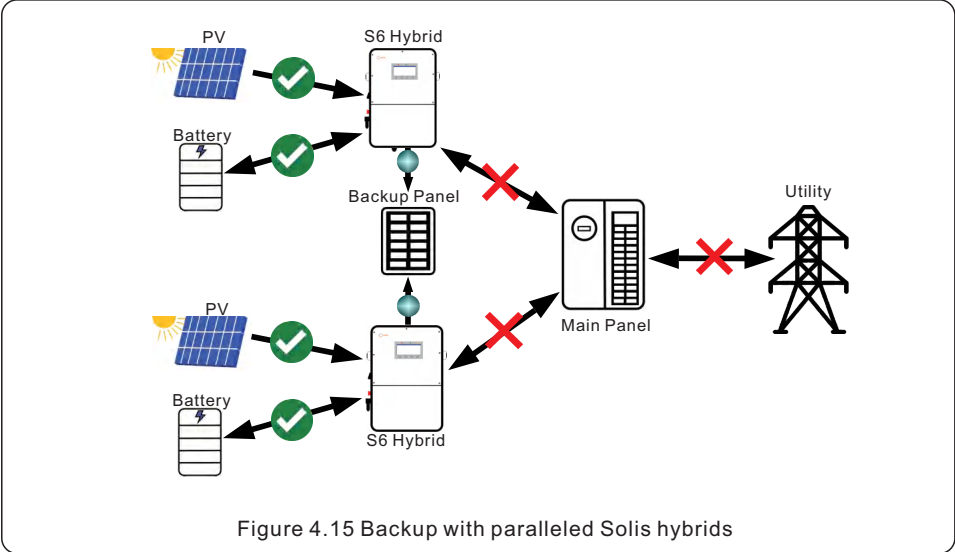

Figure 4.15 Backup with paralleled Solis hybrids

# 4. Operating Modes

---

It should first be determined what the maximum continuous current needs to be in order to meet the energy demand of the home. Up to six Solis hybrid inverters can be installed in parallel with PV and batteries to provide continuous backup power. For example, three 16 kW hybrids in parallel can provide up to 200A (66.7A x 3) of continuous power to the home loads in backup or off-grid modes. For a whole-home backup system, the average daily power consumed should be less than or equal to the average daily PV power produced over the span of a year. Otherwise, some loads should not be backed up during a grid failure. The chart below shows how much continuous backup power can be produced depending on how many inverters are installed in parallel and what size they are.

Solis Model	Total Maximum Continuous Backup Current					
	1 unit	2 units	3 units	4 units	5 units	6 units
S6-EH2P10K03 -SV-YD-L	41.7A	83.4A	125.1A	166.8A	208.5A	250.2A
S6-EH2P1 2K03-SV-YD-L	50A	100A	150A	200A	250A	300A
S6-EH2P1 4K03-SV-YD-L	58.3 A	116.6 A	174.9A	233.2A	291.5 A	349.8A
S6-EH2P1 6K03-SV-YD-L	66.7A	133.4 A	200.1A	266.8A	333.5 A	400.2A
S6-EH2P1 8K03-SV-YD-L	75A	150A	225 A	300A	375A	450A

### Backup Combiner Load Center

In the diagrams of this manual a Backup Combiner Load Center is often shown additional to the Backup Home Load Center. The Combiner is not required, but it does provide additional breaker slots to host multiple inverter breakers if one is installed. A single backup load center can be installed if there is adequate space to host all of the home load breakers in addition to the inverter breakers, provided that it is compliant with the NEC.

# 4. Operating Modes

## 4.5.1 Paralleling Requirements and Limitations

There are a few requirements to installing multiple inverters in parallel for backup power. Please note that these caveats do not apply if you are only paralleling on the grid-side. The restrictions outlined below only apply whenever you are paralleling the backup sides together. All inverters in the same system must be on the same firmware version. Please be sure to install one Solis logger per inverter.

1. Paralleled inverters must all have the same nameplate rating, or same model number.

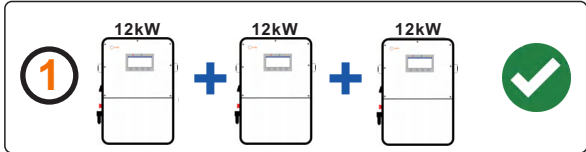

2. Do not parallel inverters that have different nameplate rating. The inverter is unable to properly balance power when they are different sizes.

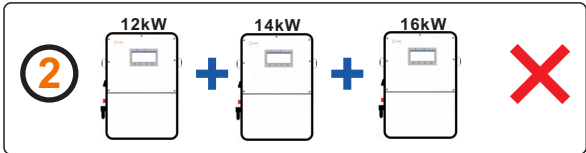

3. Batteries connected to paralleled inverters must all be of the same brand and model number. Do not install batteries of different brands or models in the same system.

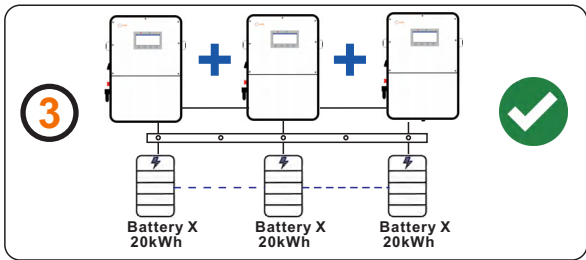

4. Do not install some inverters with batteries and some without batteries. Every inverter must either have a battery or not have a battery.

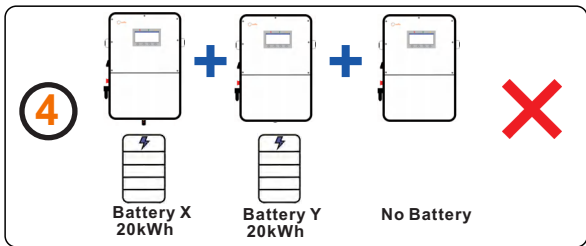

5. Do not install different sizes (kWh) of batteries on each inverter. Each inverter needs to have the exact same amount of battery capacity connected.

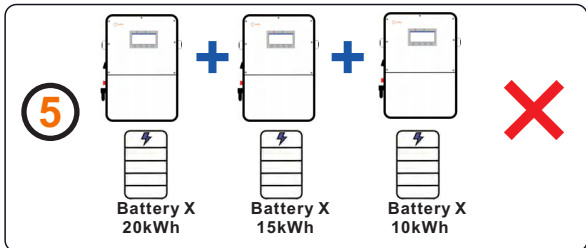

### NOTE:

These requirements must be followed to maintain the warranty status of the inverter and the batteries.

# 4. Operating Modes

## 4.6 Generator Operation

The generator must either connect to the Smart Port or the grid side of the inverter. For purely off-grid systems, a generator can be used as a grid replacement. The generator must support 2-wire dry contact for start/stop control of the generator based on battery state-of-charge %. When the inverter turns on the generator it uses the generator power to recharge the batteries and feed the home loads until either the grid returns or the battery reaches the off SOC%. There is also a generator support function that works by setting a minimum generator amount. **The generator cannot be connected to the backup side.**

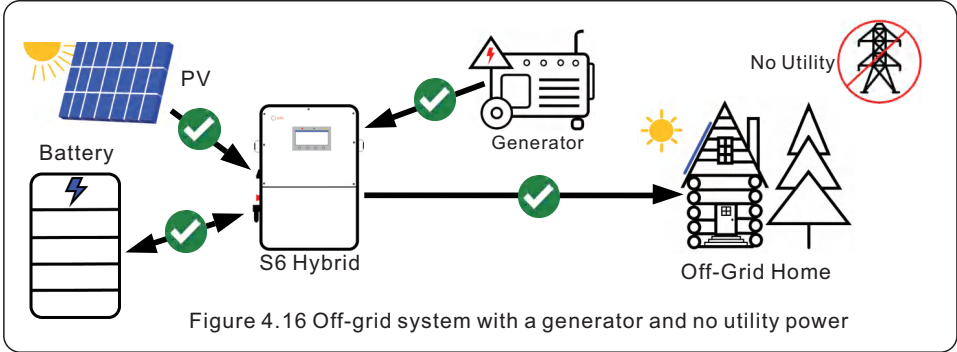

If a generator is connected to the Smart Port, it is not possible to simultaneously connect an AC-coupled PV system (ACPV) to the Smart Port. You must select either one or the other. Conversely, if ACPV is going to be connected to the Smart Port, you are not able to connect a generator to the grid side or the backup side. The inverter cannot support that type of application.

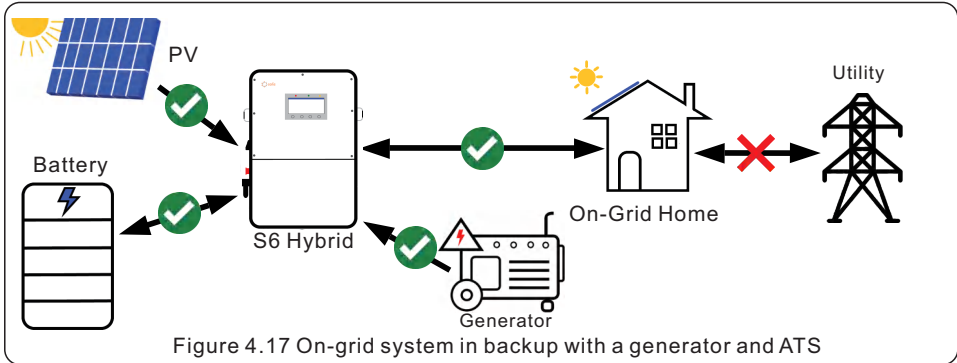

**WARNING:**

The generator must be connected to either the Smart Port or the grid-side of the inverter. Do not connect the generator to the Backup Port.



**NOTE:**

The generator must be connected in 240V split phase configuration, otherwise it may result in phase loss in the inverter and the system will be unable to operate.

# 4. Operating Modes

## 4.7 Wiring Diagrams

**Note:** The ground conductors from PV and battery to the inverter are not being shown in these diagrams but should be installed for every system.

### 4.7.1 Partial-Home Backup with One Solis Hybrid

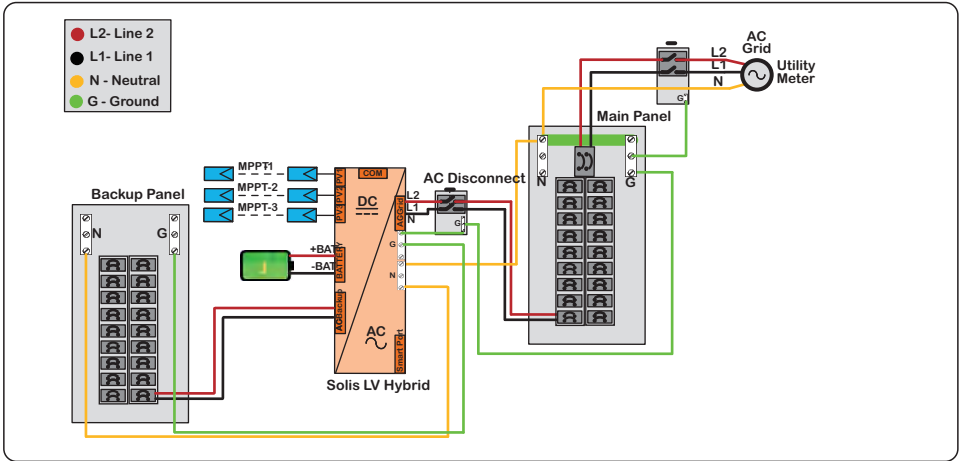

### 4.7.2 Partial-Home Backup with One Solis Hybrid and an AC-Coupled PV System

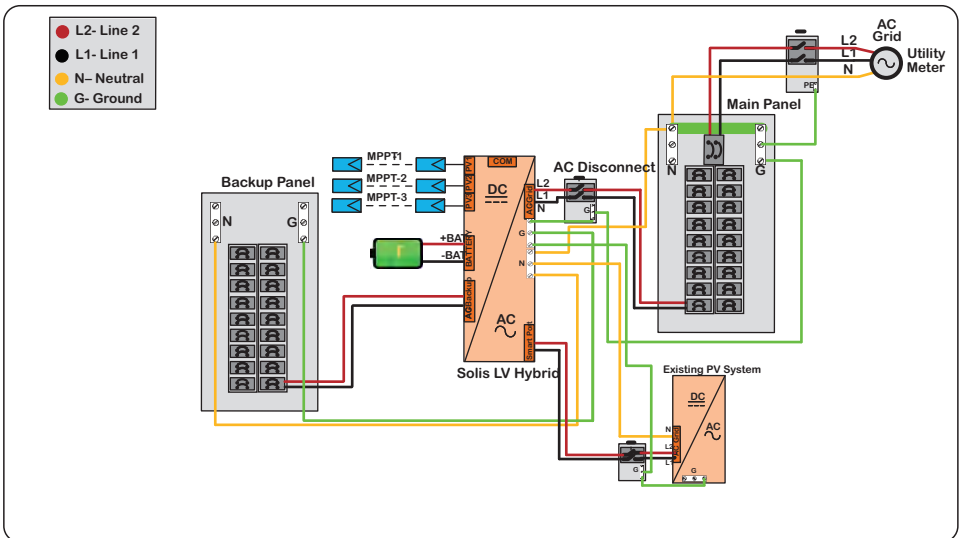

# 4. Operating Modes

## 4.7.3 Whole-Home Backup with One S6 Hybrid Inverter

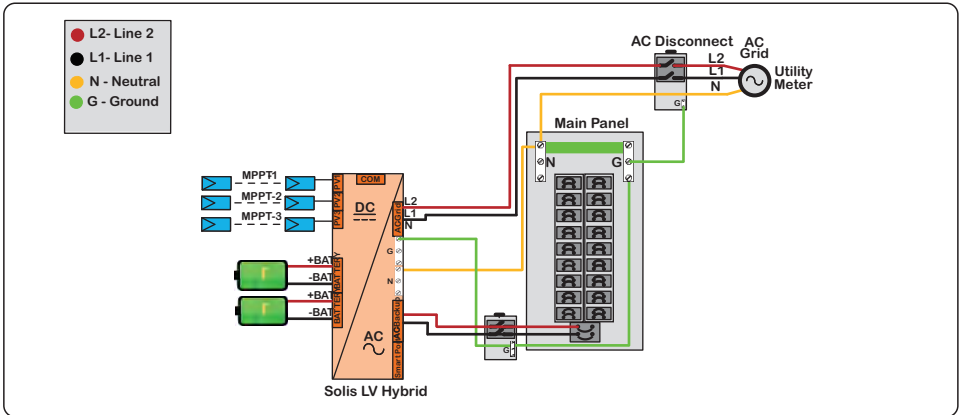

## 4.7.4 Whole-Home Backup with Multiple S6 Hybrid Inverters

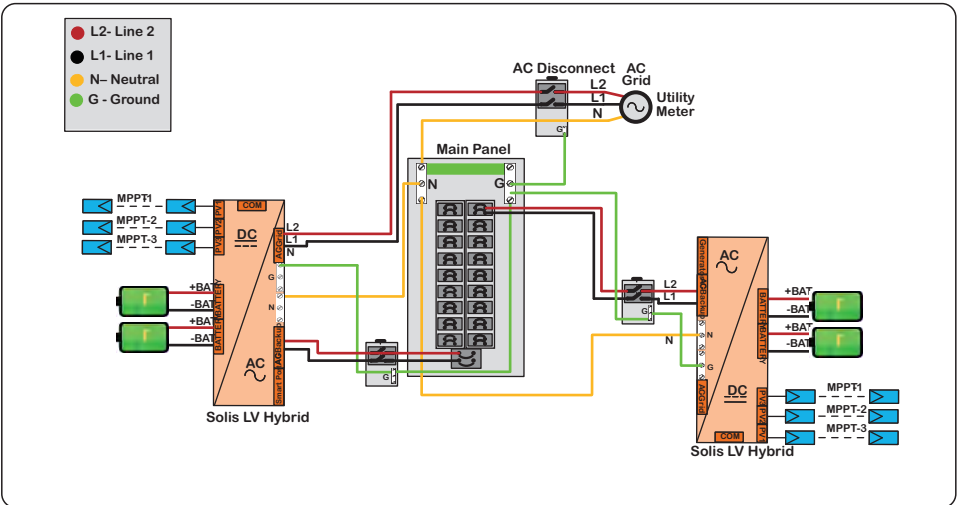

# 4. Operating Modes

## 4.7.5 Off-Grid System with a Generator and One Solis LV Hybrid Inverter

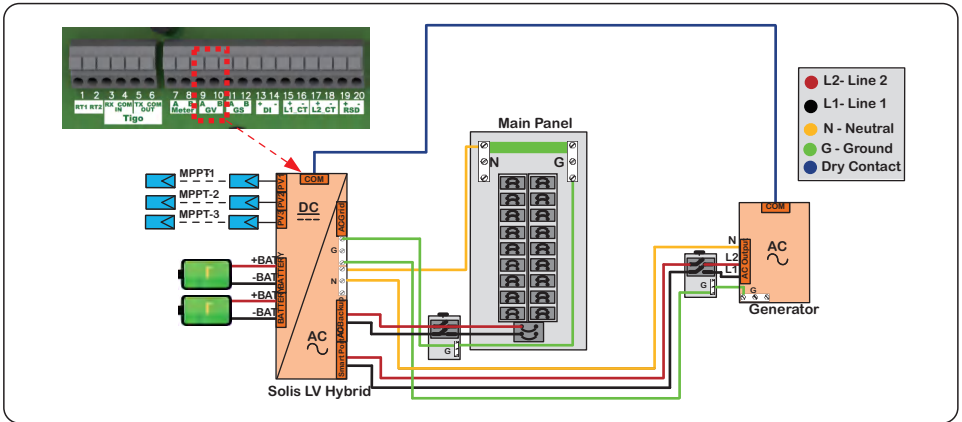

**Note:** Pins 9 (GV-A) and 10 (GV-B) should be used for the dry contact connection to the generator.

## 4.7.6 On-Grid System with a Generator and External Autotransfer Switch (ATS)

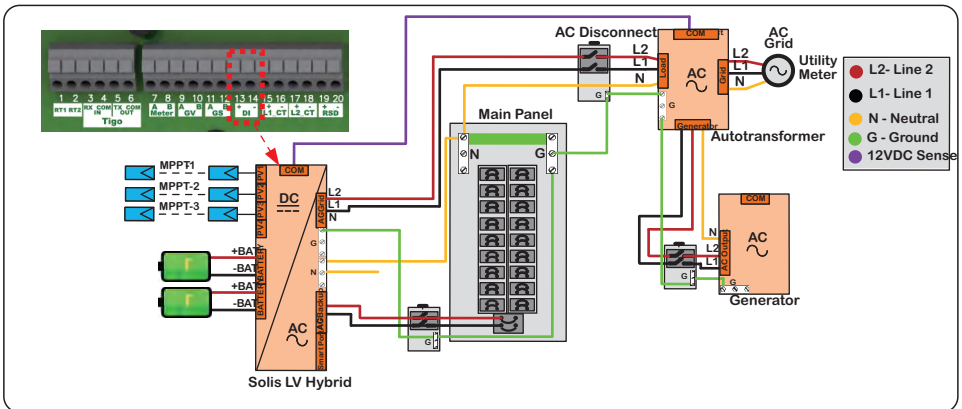

**Note:** Pins 13 (DI +) and 14 (DI -) should be used for the grid sense connection to the external ATS.



**NOTE:**

Systems with an external ATS and generator that want the inverter to control the generator turning on and off but use the ATS to switch to generator from grid during a power outage should use all four pins: GV-A, GV-B, DI+, and DI-

# 5. Installation

## 5.1 Select a Location to Install the Inverter

When selecting a location for the inverter, the following criteria should be considered:

- Exposure to direct sunlight may cause output power derating due to overheating  
It is recommended to avoid installing the inverter in direct sunlight. The ideal location is one where the ambient temperature does not exceed 40°C (104°F)
- It is also recommended to install the inverter somewhere the rain and snow will not land directly on it. The ideal installation location is on a north-facing wall under an eave.

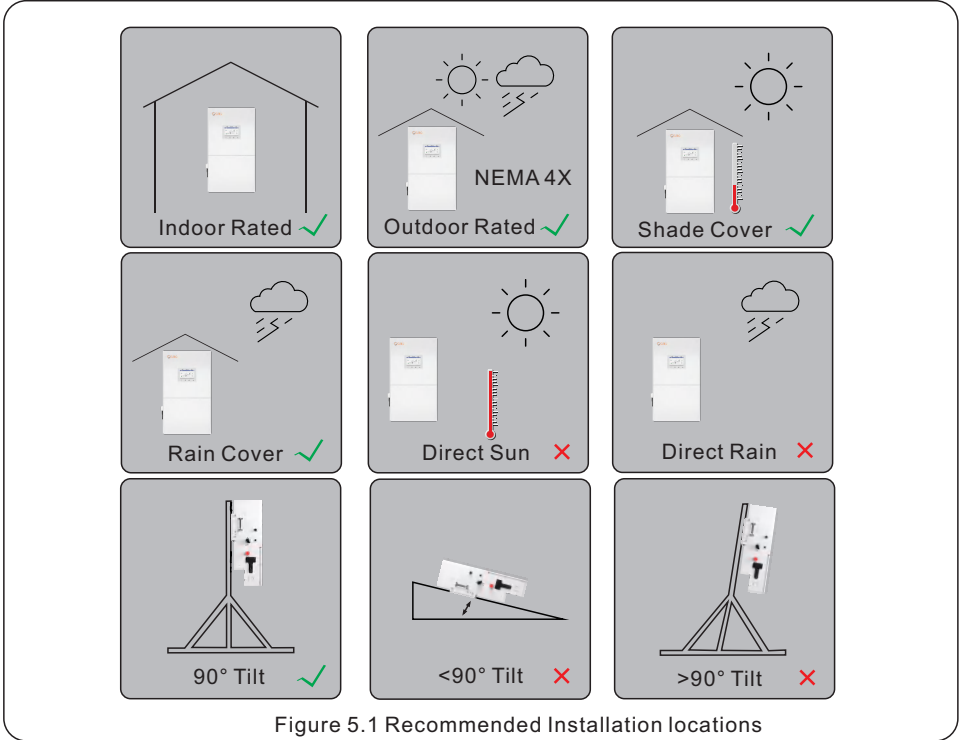

### WARNING: Risk of Fire

Despite careful installation, electrical equipment can cause fires.

- Do not install the inverter in an area that contains flammable materials, liquids, or gases.
- Do not install the inverter in a potentially explosive environment.
- The structure on which the inverter is being mounted must be fireproof.



### NOTE:

If the inverter is installed in areas with high wind and sand, it is recommended to install a wind and sand-proof barrier around the inverter.

# 5. Installation

## 5.1.4 Avoiding direct sunlight

Installation of the inverter in a location exposed to direct **sunlight** should be avoided.

Direct exposure to sunlight could cause:

- Power output limitation (with a resulting decreased energy production by the system).
- Premature wear of the electrical/electromechanical components.
- Premature wear of the mechanical components (gaskets) and user interface.

## 5.1.5 Air circulation

Do not install in small, closed rooms where air cannot freely circulate. To prevent overheating, always ensure that the air flow around the inverter is not blocked.

## 5.1.6 Flammable substances

Do not install near flammable substances. Maintain a minimum distance of ten feet (three meters) from such substances.

## 5.1.7 Living area

Do not install in a living area where the prolonged presence of people or animals is expected. Depending on where the inverter is installed (for example: the type of surface around the inverter, the general properties of the room, etc.) and the quality of the electricity supply, the sound level from the inverter can be quite high.

# 5.2 Inverter Handling

Please review the instruction below for handling the inverter:

1. The red circle below denotes the carrying handle cutout on the inverter box. Push in the cutouts on both ends of the box to form handles for moving the inverter.

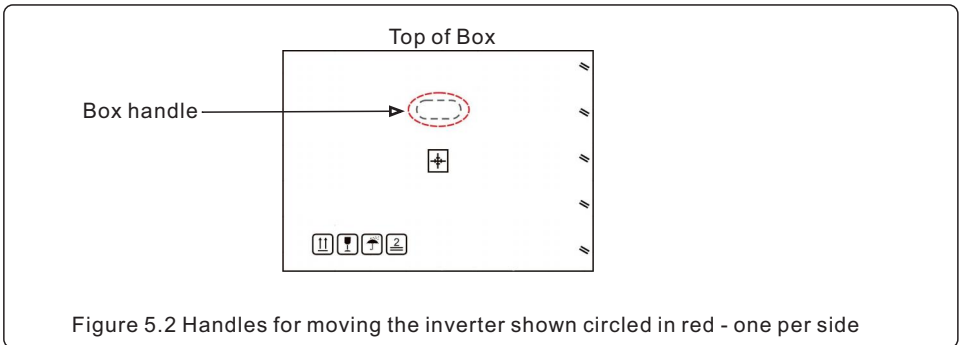



Figure 5.2 Handles for moving the inverter shown circled in red - one per side

2. Two people are required to carry and move the inverter while it is in the box.
3. When removing the inverter from the box, two people must use the handles integrated into the heat sink.
4. When setting the inverter down, do it slowly and gently. This ensures that the internal components and the outer chassis do not take any damage. Do not drop the inverter on any side from a height greater than 4 inches from the ground or it will cause damage.

# 5. Installation

When selecting a location for the inverter, consider the following:

**WARNING: Risk of Shock**



Despite careful installation, electrical devices present a shock hazard.

- Install the equipment out of reach of children if children may be present.
- Ensure that the equipment covers are always in place whenever the equipment is not being serviced.
- Never service live equipment. Always turn the equipment off first. Use a multimeter to verify that conductor voltages are zero.

**CAUTION: Hot Surface**



The temperature of the inverter heat sink can reach 167°F (75°C). Do not touch the heat sink while the inverter is operating. Do not store flammables near the inverter.

The ambient temperature and relative humidity of the installation environment must meet the following requirements:







<b>Maximum Temperature</b>  140°F 60°C	<b>Minimum Temperature</b>  -13°F -25°C	<b>Max. Relative Humidity</b>  100% Non-Condensing	<b>Maximum Altitude</b>  13,123 feet 4,000 meters
--	---	--	---

Figure 5.3 Installation environment conditions

**Load bearing structure requirements:**



Made of nonflammable materials



Max. load bearing capacity  $\geq 4$  times of inverter weight  
 $145.06 \text{ lbs} \times 4 = \mathbf{580.24 \text{ lbs}}$



Figure 5.4 Load bearing structure

## 5.2.1 Clearances

- If multiple inverters are installed on site, a minimum clearance of 12 inches should be kept between each inverter and all other mounted equipment. The bottom of the inverter should be at least 20 inches above the ground or floor (see Figure 5.7 on page 35).
- The LED status indicator lights located on the inverter's front panel should not be blocked
- Adequate ventilation must be present if the inverter is to be installed in a confined space.

## 5.2.2 Consult technical data

- Consult the technical specifications sections at the end of this manual for additional environmental condition requirements (temperature range, altitude, etc.)

## 5.2.3 Angle of installation

- This model of Solis inverter must be mounted vertically (90° not greater or less than 90° straight up).

# 5. Installation

## 5.3 Inverter Dimensions

### 5.3.1 Dimensions

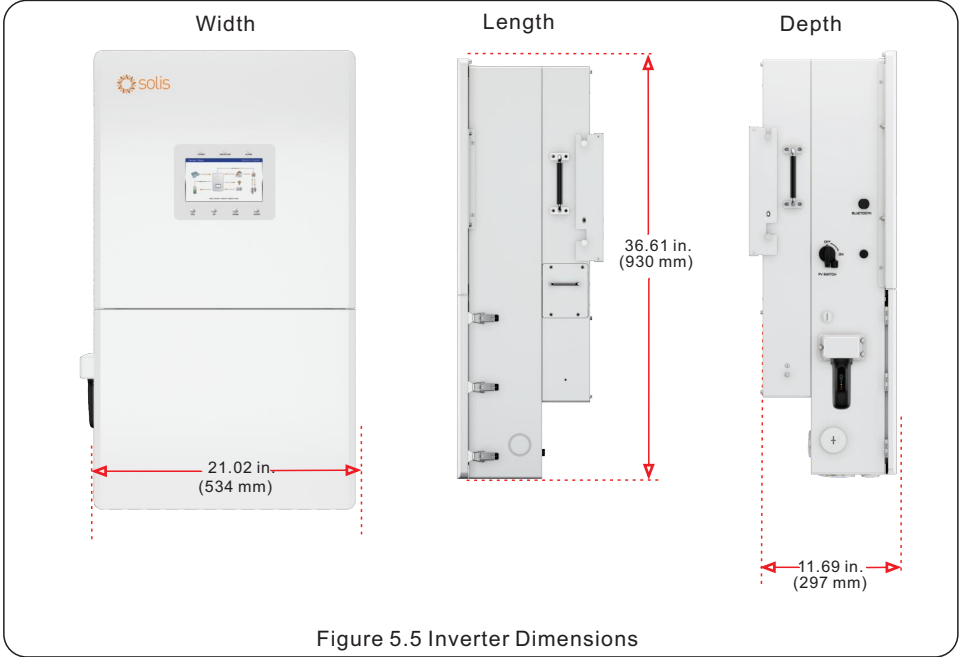

Figure 5.5 Inverter Dimensions

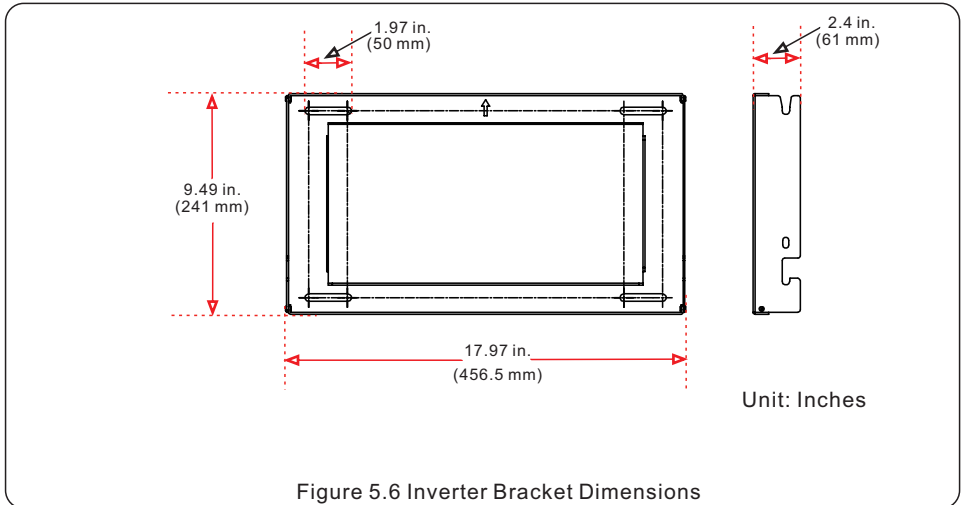
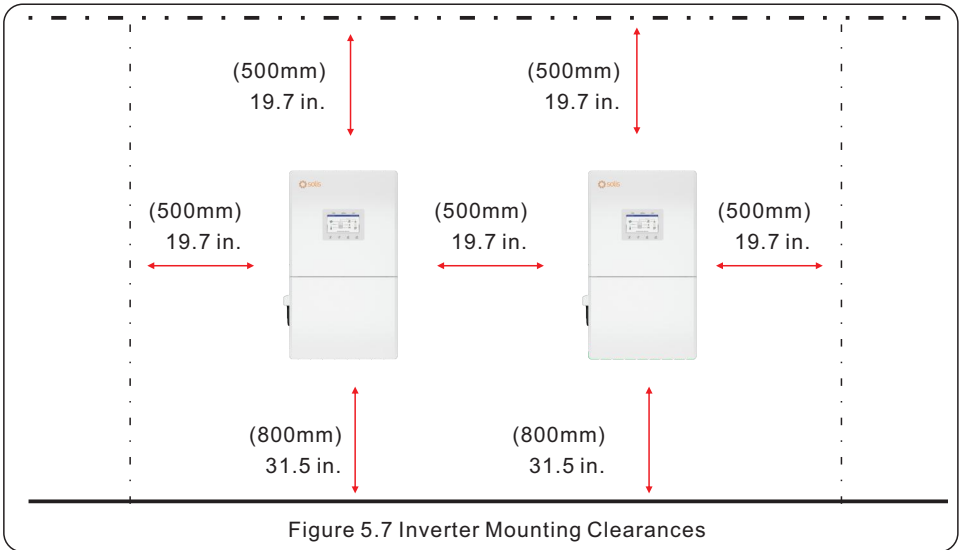

Figure 5.6 Inverter Bracket Dimensions

# 5. Installation

## 5.4 Mounting the Inverter

- Mount the inverter on a structure that is capable of bearing the weight, which is **145.06 lbs** (65.8 kg)
- The inverter must be mounted upright on a vertical structure with a tilt of 90°. A tilt greater or less than 90° may cause the inverter output power to derate.
- To prevent overheating, be sure that the inverter has adequate air flow around it. A minimum clearance of 19.7 inches (500mm) should be kept between inverter & other equipment. 31.5 inches (800mm) of clearance should be kept between the bottom of the inverter and the ground.



- Visibility of the LCD screen should be considered. Ideally, the screen should be at eye-level.
- Adequate ventilation around the inverter must be provided. Do not store anything on top of, next to, or underneath the inverter. Be sure the room the inverter is installed in stays well-ventilated.



**NOTE:**

Nothing should be stored directly on top, underneath, or against the inverter.

- When the inverter is mounted on the wall, it sticks out approximately one foot.
- Keep this in mind when selecting the installation location for the inverter. The exact dimensions of the inverter and the mounting bracket are on the previous page.

Once a suitable location has been found according to Figures 5.3 and 5.4, use figures 5.6 and 5.7 to mount the bracket to the wall. You may drill additional holes in the bracket if necessary. The steps for mounting the inverter are listed below:

1. Place the bracket on the wall and use a bubble level to make sure it is level. The arrow in the middle of the bracket points up. With a pencil or marker, mark the mounting holes. Use a drill to prepare the holes for fasteners. Fasten the bracket to the wall, using the provided concrete anchor bolts. If the wall is wood or stucco, be sure the lag bolts you use go into wall studs.

# 5. Installation



**NOTE:**

The inverter must be mounted vertically at a 90° angle.  
Four fasteners must be used to ensure the bracket does not come off the wall. At least two must embed in a wall stud to bear the inverter weight.

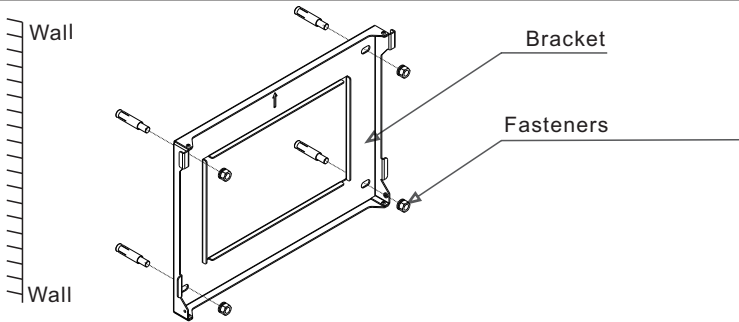

Figure 5.8 Fix the bracket to the wall

2. Lift up the inverter and align the two bolts on the inverter with the two hooks on the mounting bracket. Slowly lower the inverter down, guiding the bolts into the grooves. Then install the two set screws that are included with the inverter for stabilization.

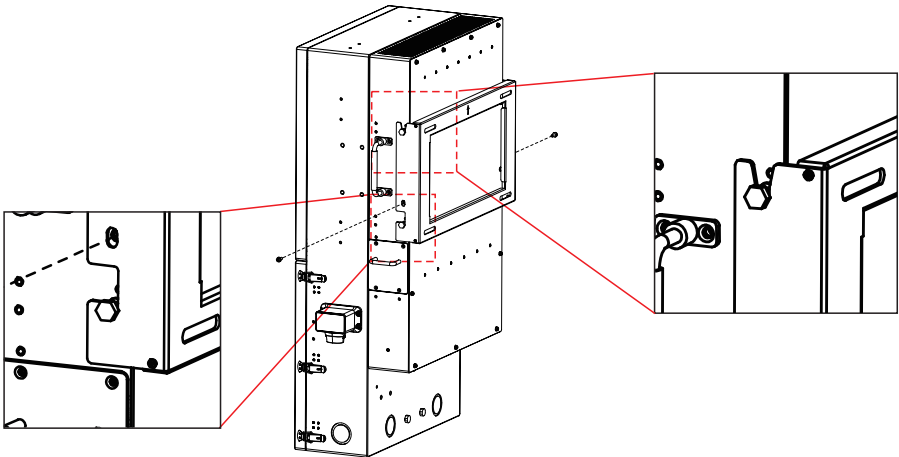

Figure 5.9 Inverter on mounting bracket and set screws



**WARNING:**

The inverter is very heavy. Please use proper lifting techniques to avoid potential injury. It is recommended that two people lift the inverter together.

# 5. Installation

## 5.5 Maximum Conductor Sizes & Torque Specs

### 5.5.1 Max. Conductor Sizes and Torque Specifications

Terminal	Max. Conductor Size	Torque Specifications
PV	8 AWG	N/A
Battery	4/0 AWG	9.6-11 ft-lbs 13-15 N-m.
AC Grid	4/0 AWG	
AC Backup	4/0 AWG	
Ground	2/0 AWG	
Neutral	4/0 AWG	
Smart Port	4/0 AWG	

Figure 5.10 Max. Conductor Size and Torque Spec Chart

#### Inverter Terminal Operation

AC and battery terminals are all 8mm Hex.

Neutral bus bar terminals use 5mm Hex.

Ground bus bar terminals use 5mm Hex

The PV terminals can be operated with fingers only, no tools.

The communication terminals require a small flat screwdriver.

Torque all terminals to 9.6-11 ft-lbs (13-15 N-m) with a torque wrench screwdriver. Do not overtighten the terminals.



# 5. Installation

## 5.6 Equipment Grounding and Neutrals

Within the inverter wire box there is a ground bar for the equipment grounding conductors to terminate. All equipment grounding conductors (EGCs) must be terminated in this bar. If there is not enough terminal space for all of the EGCs, please use a multi-port connector to provide additional terminals.

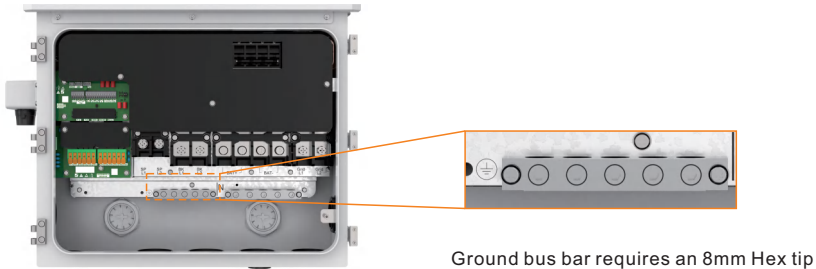

Figure 5.11 Internal Grounding Conductor Terminal Location

Steps for connecting grounding and neutral conductors to the ground and neutral bus bars:

1. Strip ½ inch of insulation off the end of the ground conductor.
2. Use an 8mm Hex torque wrench screwdriver to loosen the terminal screw in the ground bar
3. Insert the stripped end of the grounding conductor into the now open terminal.
4. Tighten the screw until it is between 9 and 11 ft-lbs. Be careful not to over tighten and strip the screw.
5. Give the conductor a gentle tug test.

There is also an external terminal on the chassis of inverter for a grounding conductor to connect

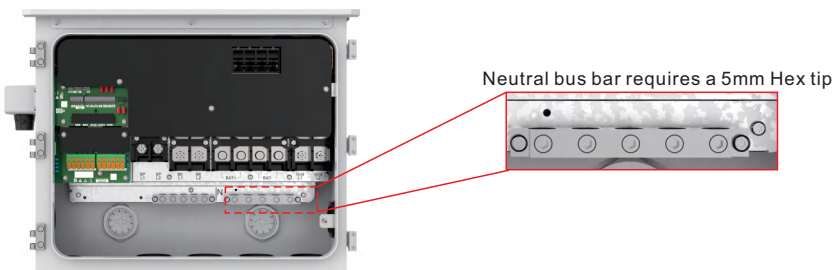

Figure 5.12 Internal Neutral Conductor Terminal Location



**IMPORTANT:**

For multiple inverters in parallel, all units must be connected to the same ground point to eliminate the possibility of a voltage potential existing between inverter grounds.

# 5. Installation

## 5.7 PV Cable Installation



**DANGER:**

Before installing the PV cables, be sure that the PV array is disconnected. Use a multimeter to verify that the PV string voltages are 0V before proceeding. If rapid shutdown is being used, then under 30Vdc per string is safe.

**Please verify the following before connecting the PV strings to the inverter:**

- Ensure the DC voltage of the PV strings will not exceed the maximum DC input voltage (550Vdc). Violating this condition will void the inverter warranty.
- Ensure the polarities of the PV strings are correct (ex: positive is positive).
- Ensure the DC-switch, battery, AC-Backup, and AC-Grid disconnects are all off.
- Ensure the PV resistance to ground is higher than 20K ohms.
- Ensure that the Isc of the strings will not exceed the maximum DC input current.

**Note:** Each PV string input/set of + and - ports is a separate MPPT

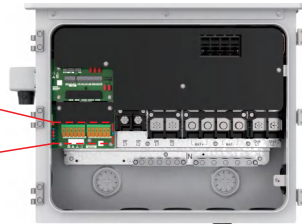
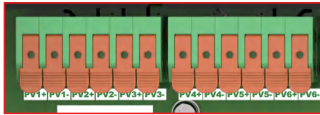

1. Strip ½ inch of sheath off the ends of each PV cable.
2. Pull up on the orange tab above the PV terminal, this opens the terminal gate.
3. Insert the end of the PV cable into the now open terminal.
4. Pull down on the orange tab and the terminal gate will clamp down on the PV cable.
5. Give the PV cable a gentle tug test to ensure that the connection is tight.
6. If the connection feels loose, repeat steps 1-5 again but push the cable deeper into the terminal before releasing the lever.

Figure 5.13 PV Cable Connection

**CAUTION:**

If the DC conductors are accidentally connected in reverse or if the inverter is not working properly, do NOT turn off the DC switch. Otherwise, it may cause a DC arc and damage to the inverter or a fire.

The steps for corrective actions are as follows:

- \*Use a DC amp clamp multimeter to measure the DC string current.
- \*If the current is above 0.5A, please wait for the irradiance on the PV array to diminish until the current drops below 0.5A.
- \*Once the current is below 0.5A, you are allowed to open the DC switch and then disconnect the PV strings from the inverter.
- \* In order to completely eliminate the potential for failure, leave the PV strings disconnected until the cause of the reverse polarity is corrected.



# 5. Installation

## 5.8 Battery Installation



**DANGER:**

Before installing the battery cables, be sure that the battery is turned off. Use a multimeter to verify that the battery voltage is 0Vdc before proceeding.

***Do not reverse the polarity of the battery conductors, this is crucial.***

1. The battery (+) and (-) cables shall only be connected to the inverter BAT terminals.
2. Run the cables into the wire box. Strip ½ inch off the ends of each cable.
3. Loosen the battery terminals using a 14mm Hex torque wrench
4. Insert the ends of the battery cables into the terminals one at a time
5. Tighten the terminals to between 9.6 and 11.06 lbf-ft (13-15 N.m) using the torque wrench
6. Give the cables a gentle tug test to ensure that they are secure

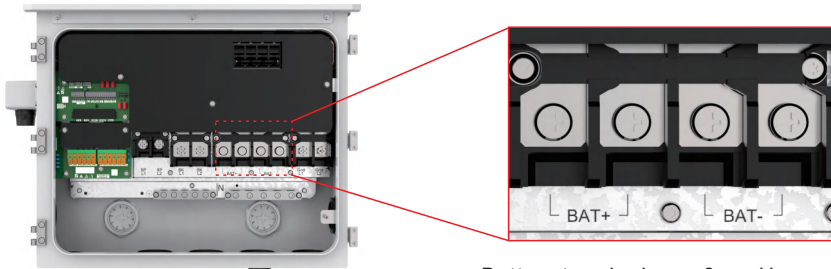

Battery terminals are 8mm Hex

Figure 5.14 Battery Cable Connection

### Battery Compatibility

This inverter only works with specific battery models. Please consult the Battery Compatibility Sheet on the Solis US website for which battery models this inverter will support. **Installing a battery that is not on the list will void the inverter warranty.** The inverter has two battery inputs and so can connect to two battery stacks at the most, unless the battery allows for paralleling multiple stacks together.

### Black Start

In a situation where there is no grid and no PV, the inverter is able to use the battery to black start. However, not all compatible batteries support this function. Be sure to consult the battery manual to determine if it is able to support black start. The battery must continue to provide voltage to the inverter such that the inverter can remain on all night until the sun comes up the next day. The inverter will not allow the loads to stay energized, only itself, until PV is available to charge the battery.



**NOTE:**

Before connecting the battery, please carefully read the product manual of the battery and perform the installation exactly as the battery manufacturer specifies in the manual



**NOTE:**

The largest cable size that will fit in the battery terminals is 2/0 AWG copper cable. Aluminum can only be used if No-Ox gel is used.

# 5. Installation

## 5.9 AC Wiring

### 5.9.1 AC Terminals

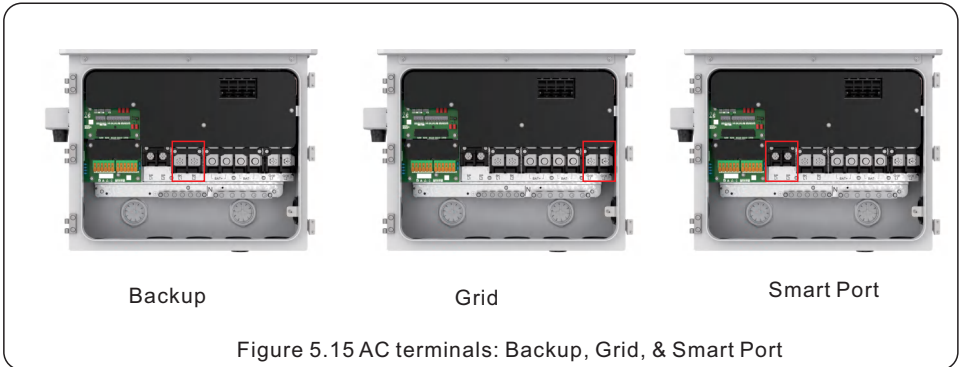

Figure 5.15 AC terminals: Backup, Grid, & Smart Port

**Backup:** This port remains energized with PV/ battery whenever the grid fails. Loads connected to the backup get power directly from the grid whenever there is not enough power available from PV/battery.

**Grid:** The inverter connects to the utility through this port. Excess PV power can be exported to the grid and the inverter can import power from the grid to charge the battery and support home loads.

**Smart Port:** This port is for connecting either a generator, an AC-coupled PV system, or a large load that can be shed during a grid outage if there is not enough power to support it (such as an EV charger).

The inverter has two AC outputs: (1) to a backup distribution panel and (2) to the main service panel that is connected directly to the utility. When utility power is lost, the Grid-side of the inverter shuts off. The backup-side of the inverter stays energized as long as there is enough PV and battery power to support the loads.

The inverter can be connected to other S6 hybrids in parallel to provide additional support to the backup loads. For whole-home backup systems, the AC grid terminals of the inverter will connect directly to the utility through a disconnect switch. The AC backup terminals will connect to the main breaker within the main service panel. The inverter is rated for 200A maximum, which is the pass through capability from the grid to the loads when grid is available.

### 5.9.2 Passthrough Power (AC Bypass)

In the event of a soft equipment malfunction the inverter will automatically switch into bypass mode. When this happens, the inverter will pass power to loads on the backup side from the grid so that the loads never lose power. There is no physical switch on the inverter for this function, it is achieved through relays within the inverter.

Should the inverter have a hard failure, the loads connected to the backup side will lose power.

During normal grid-connected operation the maximum continuous grid to backup pass-through current is stable up to 180A. Between 180A and 200A the inverter will trip for overload. However, if the main breaker is 200A, then per NEC 160A is the max. continuous power that should be imported from the grid.



**NOTE:**

The bypass/pass-through feature does not need to be enabled in the settings to function normally. This feature is automatic and turned on by default.

# 5. Installation

## Parallel System Wiring Diagram

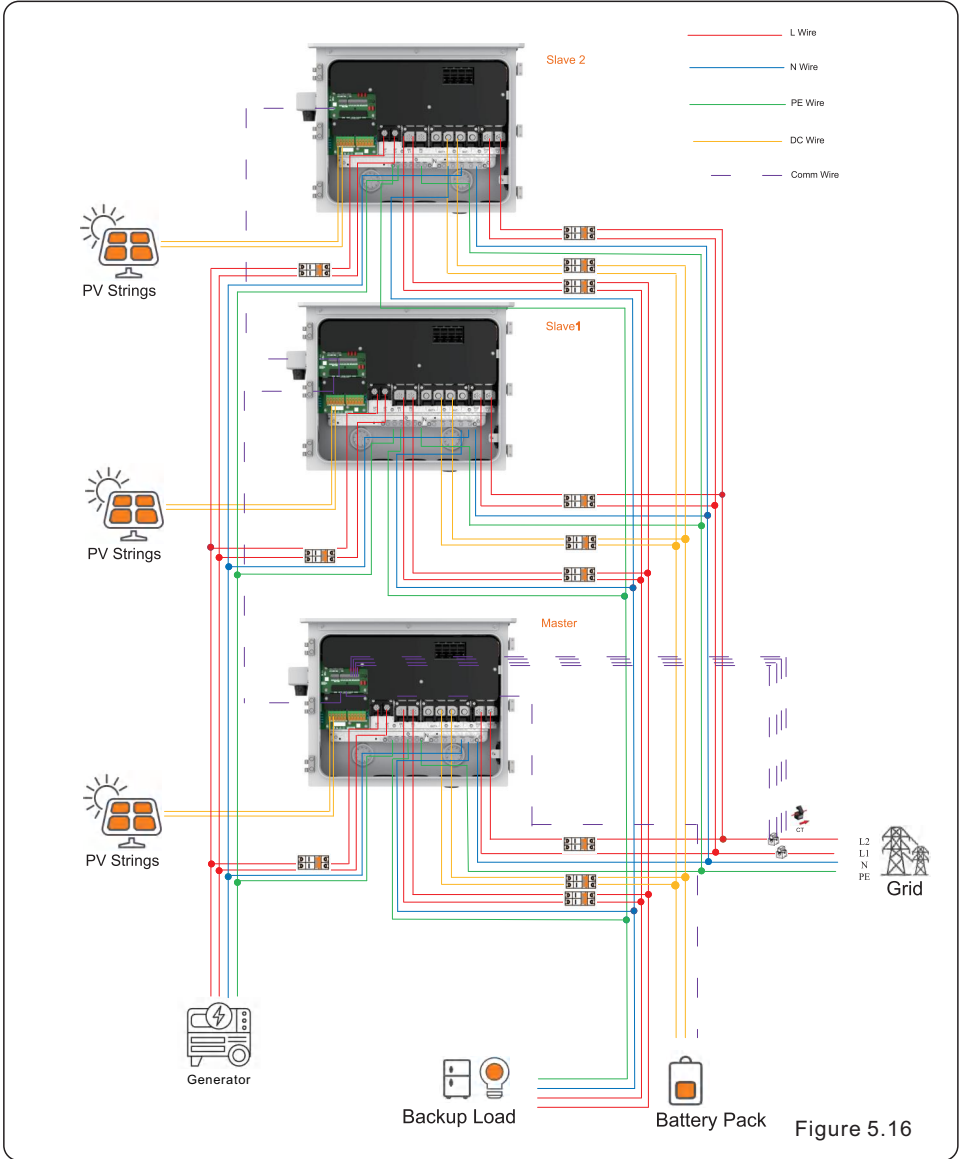

**NOTE:**

When three or more inverters are connected in parallel, please place an additional order for meter: DTSU666(CT)600A/40mA.

# 5. Installation

## Generator Connected to the Smart Port Wiring Diagram

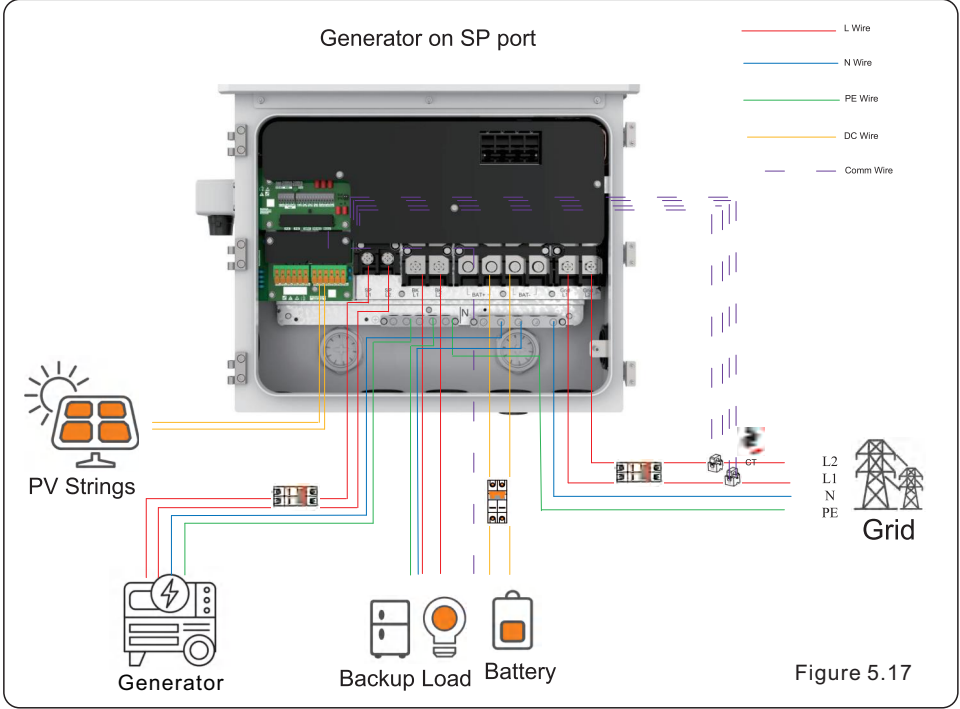

# 5. Installation

## AC Current Ratings for Sizing Over-Current Protection (OCPD)

To protect the inverter, we recommend installing a device for protection against over-current and leakage, based on the following current ratings noted in Figure 5.18

Inverter Size	Grid Max Output Current	Grid Max Pass Through Current	Backup Rated Output Current	Backup Max Output Current (10 sec)
10 kW	41.7A	200A	41.7A	83.4A
12 kW	50A	200A	50A	100A
14 kW	58.3A	200A	58.3A	116.6A
16 kW	66.7A	200A	66.7A	133.4A
18 kW	75A	200A	75A	150A

Figure 5.18 Current ratings for sizing the over current protection device (circuit breaker)



### NOTE:

The largest cable size that will fit in the battery terminals is 2/0 AWG. Copper or aluminum conductors can be connected to the terminals.

### 5.9.3 Installing the AC cables

This section explains how to install the AC conductors which will connect to both the grid and the backed up home loads. **Partial-home** backup means that a limited number of loads will be backed up whenever the grid fails. **Whole-home** backup means that every home loads will be backed up. It is crucial to design the system so that the backed up home load consumption does not exceed the available PV and battery power. The next section explains how to wire the system based on if you are installing a partial or whole-home backup system.

#### Partial-home backup

1. Bring the AC cables for the backup loads panel (backup) and the main service panel (grid) into the inverter wire box. The backup loads panel should not be directly connected to the main service panel.
2. Strip ½ inch of insulation from the ends of each cable
3. Loosen the BK-L1, BK-L2, Grid-L1, and Grid-L2 terminals using an 8mm Hex screwdriver
4. Insert the ends of the L1 and L2 conductors into the appropriate terminals one at a time
5. Use a torque wrench screwdriver to tighten the terminals to between 9.6 and 11.06 lbf-ft (13-15 N.m)
6. Give the conductors a gentle tug test to ensure that they are secure
7. If any of the conductors feel loose, repeat steps 3-6
8. Connect the other ends of the Grid L1 and Grid L2 conductors in the main service panel to a breaker and to the neutral bus bar.
9. Connect the other ends of the Backup L1 and Backup L2 conductors to the corresponding terminals within the backup service panel either to the panel lugs or to a breaker.

Note: The inverter can be ordered with a Backup breaker built into the inverter.

10. Keep all AC breakers turned OFF for now. Only turn them on when doing the commissioning.

# 5. Installation

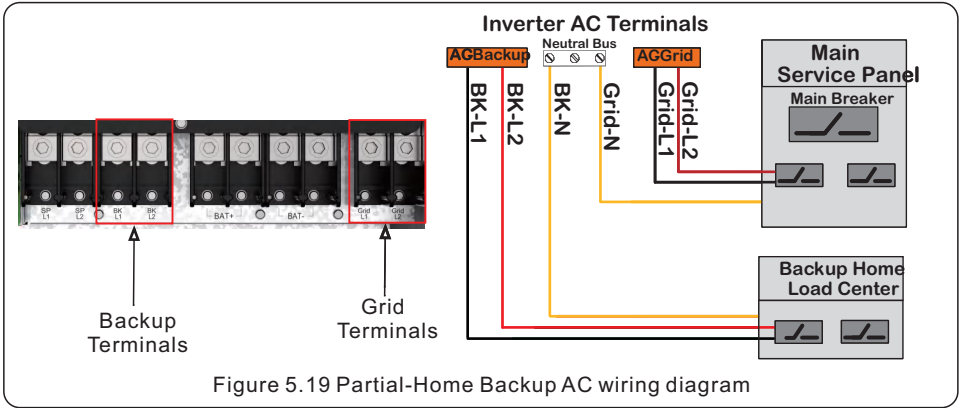

## 5.9.4 Steps for Installing the Backup Home Load Center for Partial Home Backup

1. Once you have determined which breakers supply power to the things that are to be backed up, mark the breakers so that you will be able to identify them once the panel cover is off.
2. Shut off power to the house so that it is safe to work inside of the main panel (or subpanel).
3. Remove the panel cover, use a multimeter to verify that the panel is deenergized.
4. Turn off the breakers that are to be relocated, remove the wires from them and then cap off the wires for now. Remove the breakers and then install them into the backup loads panel.
5. Run separate wires from the main panel (or subpanel) to the backup loads panel. You will need to run one wire for each breaker that you are relocating.
6. In the main panel, connect the cables that you ran to the backup loads panel to the circuit cables that you capped off earlier. This can be done with wire nuts or something similar.
7. In the backup panel, terminate the wires in the breakers that you moved from the main panel.
8. Be sure to label the breakers in the backup loads panel so that they can be identified.

### Whole-home backup

1. Conductors for the AC Grid terminals should connect directly to the AC disconnect switch just after the utility meter. Conductors for the AC Backup terminals should go to the main breaker within the main service panel. The inverter is rated for 200A, the maximum that the inverter can connect to.
2. Strip ½ inch of insulation from the ends of each cable
3. Loosen the BK-L1, BK-L2, Grid-L1, and Grid-L2 terminals using an 8mm Hex screwdriver
4. Insert the ends of the L1 and L2 conductors into the appropriate terminals one at a time
5. Use a torque wrench screwdriver to tighten the terminals to between 9.6 and 11.06 lbf-ft (13-15 N.m)
6. Give the conductors a gentle tug test to ensure they are secure
7. If the wire feels loose, repeat steps 3-6
8. The neutral conductors from the utility and the main service panel should both terminate in the neutral bus bar of the inverter.
8. Keep the AC disconnect switch and main breaker OFF for now, turn them on during commissioning.

# 5. Installation

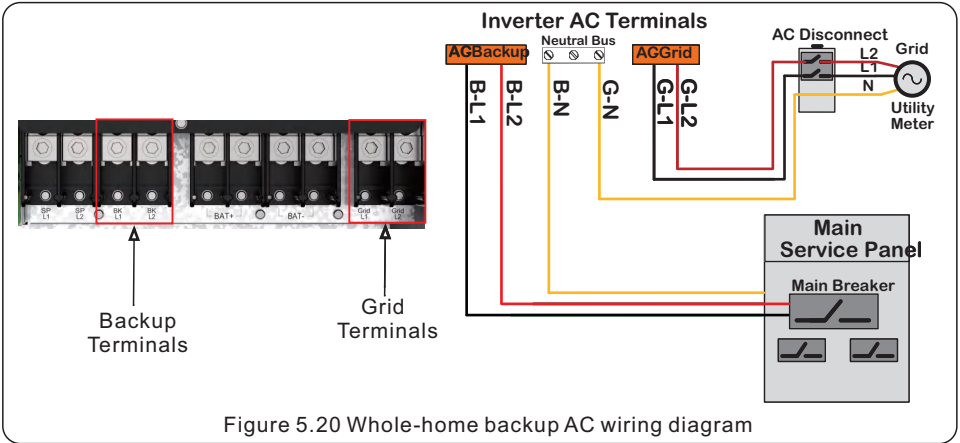

## 5.10 Generator, AC-Coupling, and Load Control

The inverter has a set of terminals called the “Smart Port”. Here you can connect either a generator, an AC-coupled PV system, or a large load such as an AC-EV charger. The input is rated for 100A max. This means that a 24kW generator is the largest that can be connected. Alternatively, a 100A load or 100AAC-coupled PV system could be connected instead. There are two pins DI + and DI - which can be connected to a 12V source from an external ATS or load which allows the inverter to control it.

### 5.10.1 Smart Port Location

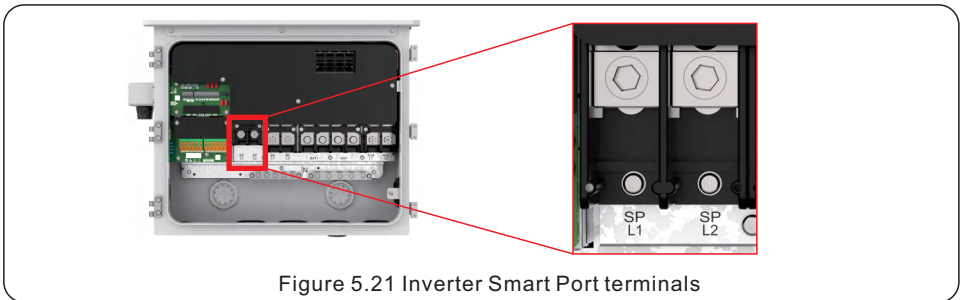

#### Smart Port Wiring

1. Bring the AC cables for the generator, load, or AC-coupled system into the inverter wire box.
2. Strip ½ inch of insulation from the ends of each conductor.
3. Loosen the SP-L1 and SP-L2 terminals using a 5mm Hex screwdriver
4. Insert the ends of the L1 and L2 conductors into the appropriate terminals one at a time
5. Use a torque wrench screwdriver to tighten the terminals to between 9.6 and 11.06 lbf-ft (13-15 N.m)
6. Give the conductors a gentle tug test. Repeat steps 3-5 if the conductors feel loose.
7. Connect a neutral conductor to the neutral bus bar and a ground conductor to the ground bus bar.

# 5. Installation

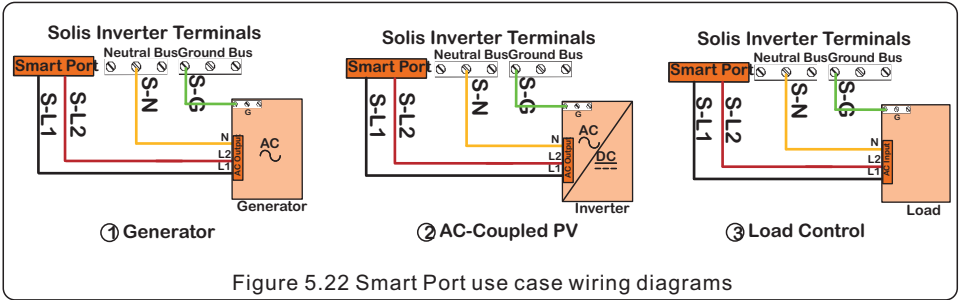

## 5.11 Inverter Communication

### 5.11.1 Communication Terminals Overview

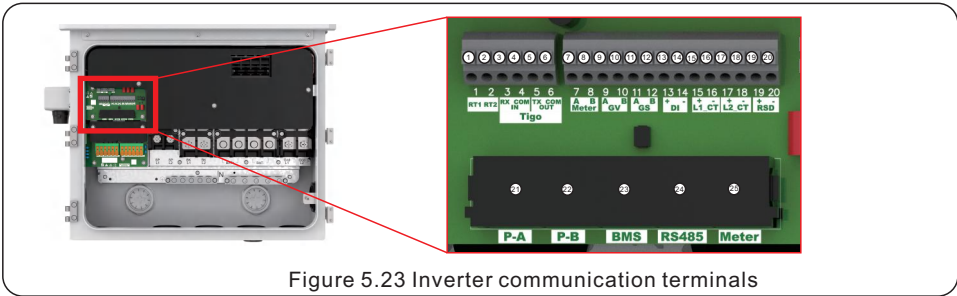

The inverter communication terminal block consists of x20 pins and x5 RJ45 ports. The table on the next page explains the purpose of each port. For RS485 connection to the inverter, use the RS485 ethernet port. Email the Solis service team for the Modbus map.

The COM port on the side of the inverter is where you can connect a Solis data logger for remote monitoring on SolisCloud.

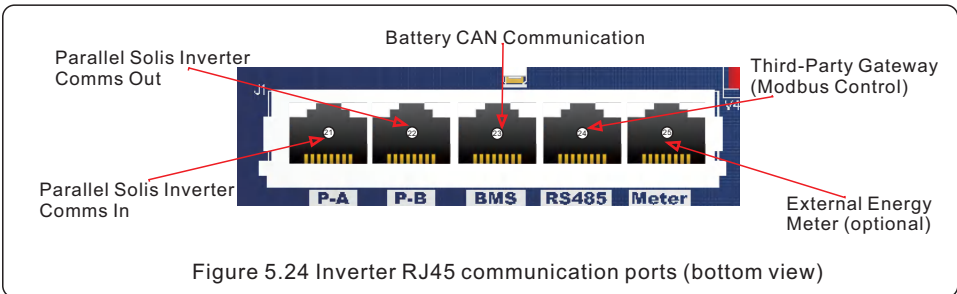

**IMPORTANT:**

Communication cables must either be shielded or run outside of conduit and raceways where high voltage conductors are being run.

# 5. Installation

NO.	Port	Function	Acceptable Wire Size Range
1	RT1	Lead-acid battery temperature sampling	22-16 AWG
2	RT2		
3	Tigo Rx IN +	Tigo transmitter RS485 in (for daisy chaining multiple transmitters together)	
4	Tigo RX IN -		
5	Tigo TX OUT +	Tigo transmitter RS485 out (for daisy chaining multiple transmitters together)	
6	Tigo TX OUT -		
7	Meter A	External energy meter RS485	
8	Meter B		
9	GV A	Generator two-wire dry contact	
10	GV B		
11	GS A	Reserved (not for use)	
12	GS A		
13	DI +	Grid sense 12VDC for distinguishing grid from generator power	
14	DI -		
15	L1 CT +	L1 CT wires for grid current sensing	
16	L1 CT -		
17	L2 CT +	L2 CT wires for grid current sensing	
18	L2 CT -		
19	RSD +	External rapid shutdown switch	
20	RSD -		
10	P-A	Parallel inverter communication in	RJ45
11	P-B	Parallel inverter communication out	
12	BMS	Battery BMS CAN communication	
13	RS485	RS485 input for third-party gateway	
14	Meter	External meter communication	

Figure 5.25 Inverter communication ports explained

### Installing the communication wires:

First, strip ¼ inch off the end of the com wire.

1. Use a technician screwdriver to push and hold the small square button above the terminal. Hold it to keep the port open.
2. Insert the stripped end of the com wire into the open terminal.
3. Remove the screwdriver and the terminal will clamp down on the wire.
4. Finally, give the cable a gentle tug to ensure that it is firmly secured. If it is not, repeat steps 2-5 but push the wire deeper into the terminal before releasing the screwdriver.

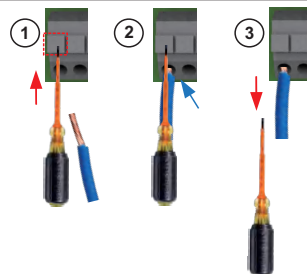

# 5. Installation

## 5.11.2 CT Direct to Inverter Wiring (No External Energy Meter)

The inverter comes with two CTs that must be installed for full functionality of the inverter. The CTs get installed on the L1 and L2 conductors from the grid to the inverter. The white CT lines are positive and the blue CT lines are negative.

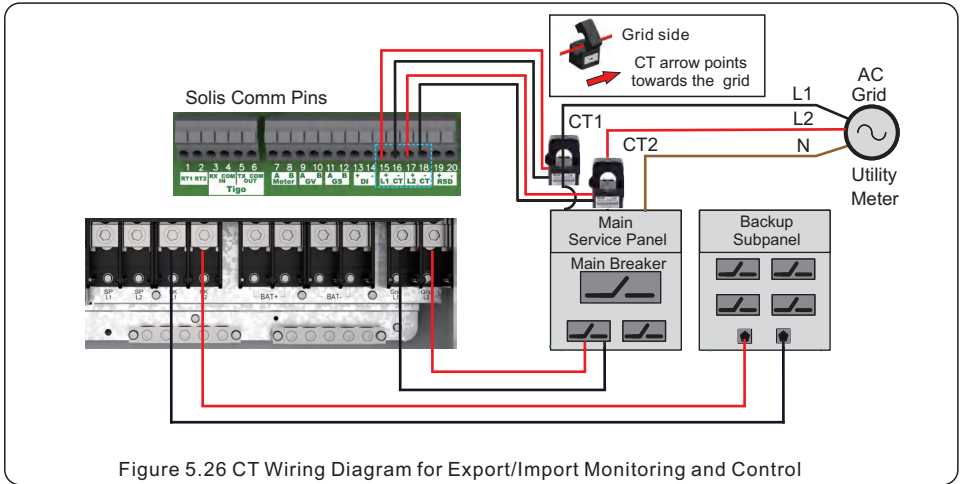

Figure 5.26 CT Wiring Diagram for Export/Import Monitoring and Control

The CTs must be installed in order to have a fully-functioning system. If the CTs are not installed, key functions such as export power control and default energy storage modes will not be available. It is possible for the system to function without the CTs, but the capabilities will be limited. After installing the meter, in order to ensure correct wiring, please use a multimeter to measure the voltage of grid L1 and meter L1. The voltage should be between 0-5V, and L2 should be the same. If it is not, please check switch L1 and L2 at the meter so that the phases are matched up.

## 5.11.3 Battery Communication

### CAN from Inverter to the Battery Management System (BMS)

Connect a standard ethernet cable from the BMS RJ45 port in the inverter to the battery CAN port. If the battery has pins for CAN instead of an RJ45 port, the diagram on the next page shows which two wires to use for CAN-H and CAN-L at the battery end.

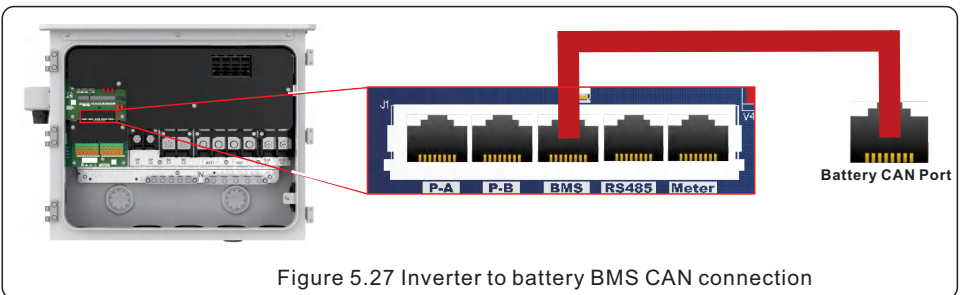

Figure 5.27 Inverter to battery BMS CAN connection

# 5. Installation

## 5.11.4 Battery Communication Wiring Table

Some batteries do not have an RJ45 port. If this is the case, use a standard ethernet cable to connect to the inverter BMS port. At the battery end, split the cable and use the blue wire for CAN-H and the blue-white striped wire for CAN-L.

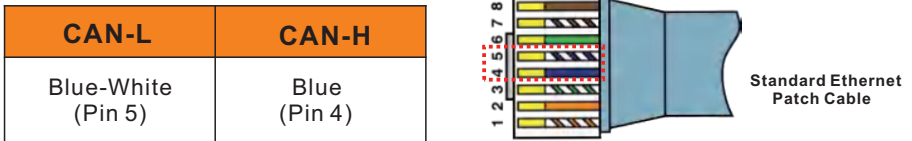

Figure 5.28 Battery Communication Wire Color Chart



**IMPORTANT:**

Solis cannot guarantee normal operation with any battery that is not on the battery compatibility list. It is possible to install a battery that is not on the list, but Solis cannot provide support or honor the inverter warranty.

### Battery Manual and Battery Firmware

Please be sure to read through the battery manual for proper installation steps. The battery manual should be provided with the battery or it can be downloaded from the battery manufacturers website directly. It is very important to update the firmware of the battery during the installation and commissioning of the system. Failing to update both the inverter and the battery firmware can lead to communication issues and alarm codes like CAN\_Comm\_Fail & No-Battery.



**NOTE:**

Some alarm codes are being relayed from the battery. These alarms are caused by an issue with the battery itself. The troubleshooting section of this manual explains how to diagnose and treat each alarm.

## 5.11.5 Parallel Inverter Communication

There are two RJ45 ports reserved for communication between Solis hybrid inverters only. Those ports are P-A and P-B. Connect a standard ethernet cable from the P-B port of the master inverter to the P-A port of the slave inverter. Do not connect the P-A port of one inverter to the P-A port of another inverter. Parallel settings will be configured during the commissioning process later in this manual..

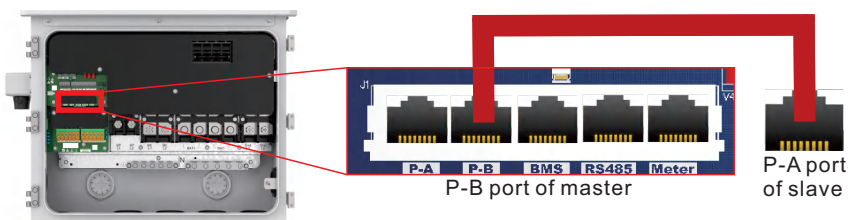

Figure 5.29 Multiple Inverter Parallel Communication

# 5. Installation

---



**NOTE:**

The master inverter will manage the output power of the slave inverter. If any of the inverters in the system have an alarm, the system will behave abnormally.

## 5.11.6 Paralleling Rules

In order to ensure normal operation and the safety of the equipment, the following rules must be followed when paralleling multiple inverters on the backup-side.

1. When connecting inverters in parallel, it is mandatory to match their sizes. For example, pair a 16kW inverter with another 16kW inverter. Do not parallel inverters of different sizes on the backup-side.
2. Before parallel connection, verify that both inverters are operating on the same firmware version. The inverters must never be on different versions of firmware.
3. Up to three hybrid inverters can be installed together in parallel, no more than that.
4. The energy meter and the data logger only need to be connected to the master. But to update the firmware, each inverter needs to have its own data logger connected to it.
5. All inverters in the system must be connected to the same ground point to eliminate the possibility of a voltage potential existing between inverter grounds.
6. Each inverter must have its own PV strings connected to it, as per the DC input PV specifications of the inverter. It is ok to have some inverters with only battery and no PV.
7. The parallel settings for each inverter must be configured prior to initiating operation.
8. Prior to initiating full system operation it is essential to verify that each inverter operates normally. Set each inverter one-by-one for single operation, ensure there are no alarms during operation, shut it down, and then go to the next inverter.

**Note:** These rules apply only to paralleling the backup ports of the inverters together. If the inverters are being paralleled on the grid-side only then these rules can be ignored.



**NOTE:**

A maximum of six (x6) inverters can be paralleled together on the backup side.

# 5. Installation

## 5.11.7 Inverter Bluetooth Network

The Solis inverter generates a localized Bluetooth network which allows technicians to interface directly with the inverter using a smart phone or tablet. The accessory kit includes a Bluetooth antenna. Remove the black protective cap from the "BLUETOOTH" port on the side of the inverter by twisting it counter-clockwise. Attach the Bluetooth antenna to the port by rotating it **counter-clockwise (not clockwise)** until it feels tight. Please note, the antenna only extends the range of the inverter Bluetooth network from 3 feet to about 10 feet. It is **not** required for the Bluetooth network to function normally. Please be sure to tighten the antenna until it feels snug. The angle of the antenna is not important does not matter. It can be bent to point up, down, or whichever direction best suits the installation.

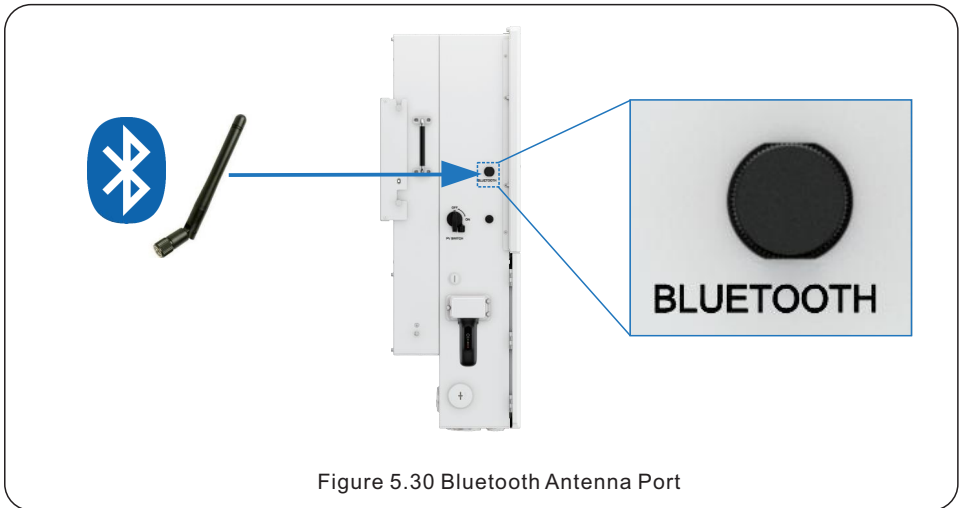

Figure 5.30 Bluetooth Antenna Port

# 5. Installation

## 5.11.8 Generator and External ATS Control

### Off-Grid Generator Using Dry Contact 2-Wire Start/Stop (GV pins 9 and 10)

For purely off-grid systems, a generator can be used as a grid replacement. The inverter uses dry contact two-wire start to turn the generator on when the battery SOC discharges to a specified limit. Generator power is used to charge the batteries and supply the home loads when the PV power is insufficient. The generator is turned off once the battery SOC reaches another specified limit.

Connect the generator dry contact to pins 9 (GV-A) and 10 (GV-B).

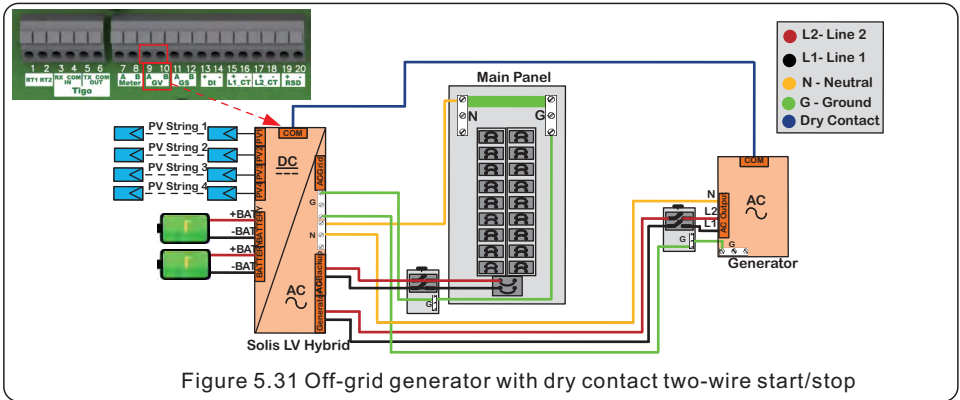

Figure 5.31 Off-grid generator with dry contact two-wire start/stop

### On-Grid Generator with External ATS Using 12V Sense (DI pins 13 and 14)

Some on-grid systems use an external ATS to isolate from the grid during a power outage and control the generator start/stop. The inverter has a 12VDC input from the external ATS to determine if the AC power coming into the Grid input is from the grid or from the generator. Connect a 12VDC two-wire supply from the external ATS to pins 13 (DI +) and 14 (DI -).

When the sense voltage is low or absent, the inverter will recognize that the generator is on and not grid. When the 12V sense voltage is high, inverter recognizes that grid is on and not generator. Alternatively, the smart port can be connected to a load or AC-coupled system. The 12V signal can be used to control power to a load or from an AC-coupled PV system instead of a generator.

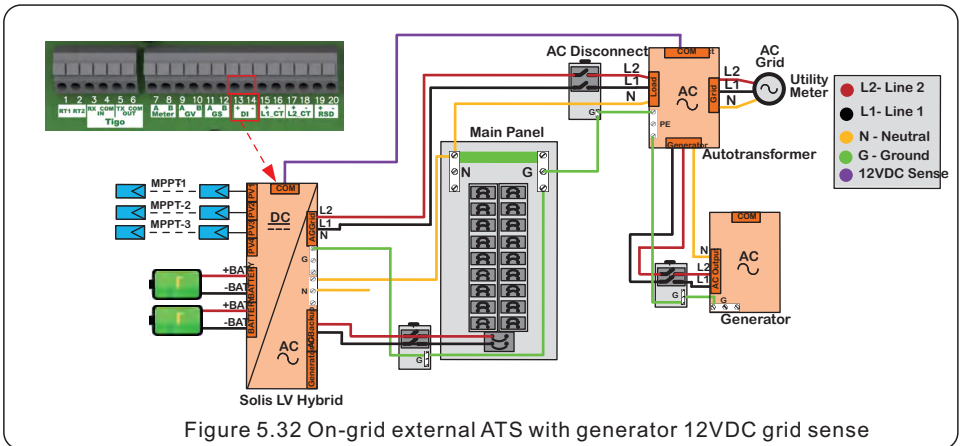

Figure 5.32 On-grid external ATS with generator 12VDC grid sense

# 6. Commissioning

## 6.1 Pre-Commissioning & Start-Up Procedure

1. Visually inspect each piece of equipment in the system closely.
  2. Check all conduit and cable connection points to ensure they are tight.
  3. Verify that all system components have adequate space for ventilation.
  4. Follow each conductor from end to end. Confirm that they are all terminated in the proper places.
  5. Ensure that all warning signs and labels are affixed on the system equipment.
  6. Check that the inverter is secured to the wall and is not loose or wobbly.
  7. Prepare a multimeter that can do both AC and DC amps.
  8. Use the multimeter to measure the PV string voltages in free air. With RSD the voltages will be low.
  9. Land the PV strings, turn on the grid-side breaker and the battery. Keep the inverter DC switch turned off. Measure the PV string voltages again. Verify that the polarities and voltages are correct.
- Note:** if the PV voltages are still low with the PV strings landed and the grid-side breaker turned on, check the rapid shutdown switch on the side of the inverter. Give it a clockwise twist to pop it out.
10. Check the AC voltages coming from the wall. Check the battery DC voltage and verify polarity.
  11. Leave the inverter DC switch turned off for now. Only turn it on once you are ready to put the system into normal operation. Leave the battery on and the AC breaker connected to the grid-side on as well.
  12. Download the battery app, register an account, and then be sure to update the battery firmware if there is a new version available. This step is very important and skipping it can lead to comms issues.

The next steps will be to install a Solis logger, download the SolisCloud application, register a new account on SolisCloud, and then configure the inverter settings using the SolisCloud app.

After that is all done, the logger will need to be connected to the Wi-Fi and configured using SolisCloud.

## 6.2 Solis Loggers & Third-Party Gateways

### 6.2.1 Solis Monitoring with Solis Data Loggers

For remote monitoring and control of the inverter using the Solis monitoring portal, a Solis data logger must be installed. The logger gets plugged into the port on the side of the inverter shown in the figure below. First, remove the black plastic protective cap from the port by squeezing in both tabs on either side simultaneously while pulling down on the cap. Insert the logger into the port by pressing up evenly on both sides, **do not twist the logger**. The logger port is USB-A and only supports USB versions of Solis data loggers, not the 4-pin versions. The Solis logger can only report to SolisCloud.

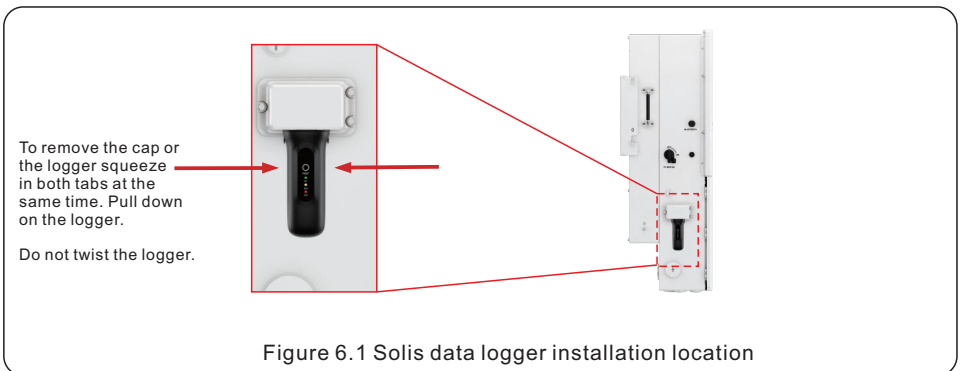

# 6. Commissioning

## 6.2.2 Compatible Solis Loggers

This inverter is compatible with only one type of Solis logger: S2-WL-ST, which has both a Wi-Fi and a local area network (LAN) option consisting of an RJ45 port for direct connection to a router.

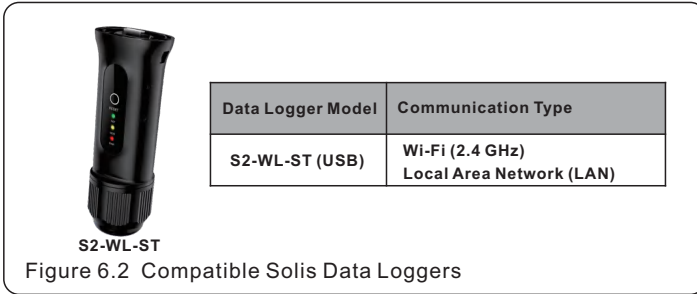

## 6.2.3 Third-Party Monitoring with RS485 Modbus

If third-party monitoring is to be installed, connect the third-party gateway to the RS485 port of the inverter. Use pin 1 (orange-white stripe) for RS485B and pin 2 (orange) for RS485A. Be sure to not connect a Solis logger at the same time or there will be communication issues due to Modbus address conflict. The Solis hybrid inverter Modbus map can be downloaded from the Solis website or requested from the Solis service and support team. The inverter supports SunSpec Modbus.

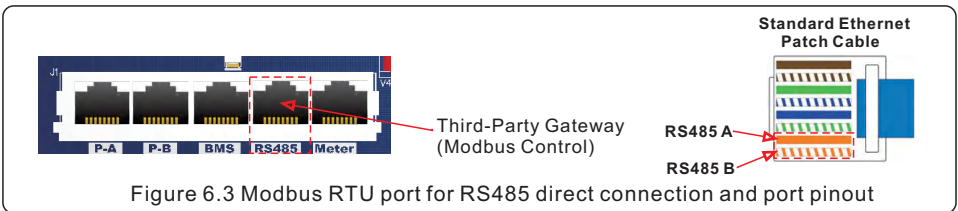

## 6.3 SolisCloud

SolisCloud is the monitoring platform where inverters can be monitored remotely. You will need to download the SolisCloud app and then register a new account. Please scan the QR code to pull up the app in the App Store or search “SolisCloud” and then look for the icon shown in the middle of the QR code. There are two account types available: Installer and Owner

**Installer:** for technicians and anyone that is not the asset owner such as the homeowner where the system is being installed. Installer accounts are for fleet management and are able to remotely control registered plants remotely through SolisCloud.

**Owner:** for homeowners who typically only have a small number of sites and are only looking to monitor their system(s) and not have any control.

Once the account registration has been completed, log into the SolisCloud app. You will use the app to configure the Wi-Fi settings of the Solis logger and the inverter settings while on-site.



# 6. Commissioning



**NOTE:**

SolisCloud data is stored at Amazon Web Services (AWS) server in Germany. All data is stored indefinitely and is not deleted periodically. Solis is the OEM for the inverters as well as the loggers.

## 6.4 Configuring the Inverter Settings

### Connect to the inverter with the SolisCloud application

Turn your phone Bluetooth on and then in the SolisCloud app tap *Service*, then tap *Local Debugging*, and then tap *Connect with Bluetooth*. The name of the inverter's Bluetooth network with display as "INV\_" and then the inverter serial number. Tap on the inverter to connect to it.

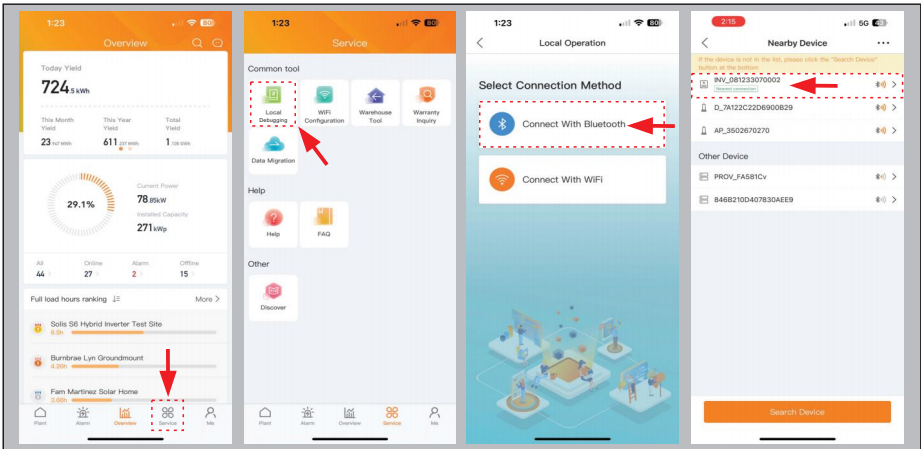

The next screen will prompt you to create a password. Once you set the password, write the password on something and then leave it inside of the inverter for anyone that returns to the site in the future.

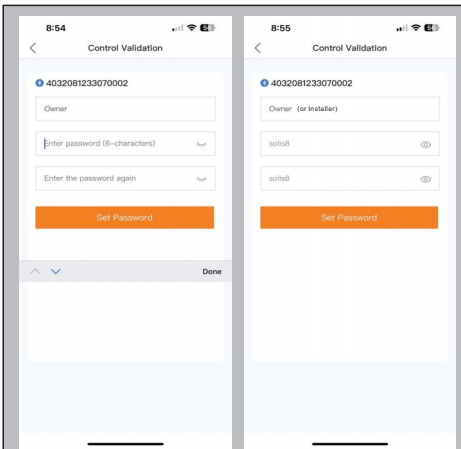

If the password is forgotten, contact the Solis service and support team and ask them to reset it for you.

You can access the same settings through the LCD screen that you can through this Bluetooth tool.

If the data logger plugged into the inverter is connected to the internet then all of the settings configuration and commissioning can be done remotely through SolisCloud.

Make sure that you have registered your account as the organization for the plant when you are making a new plant on SolisCloud. This will give you access to modifying the settings.

# 6. Commissioning

## Configure the Quick Settings

After setting a password, you will be prompted to configure the Quick Settings. First, tap the toggle switch for *Follow Phone Time* to match the inverter time to your phone date and time. Tap Next Step. Select the battery that is installed from the list. If no battery is installed, tap *No Battery*. Tap Next Step. If only CTs are installed, tap Meter Setting, then select CT. CT orientation can be electronically reversed by tapping CT Direction and then changing Forward to Backward. This is the same as physically flipping the CTs around on the L1 and L2 conductors. Tap Next Step when you are ready.

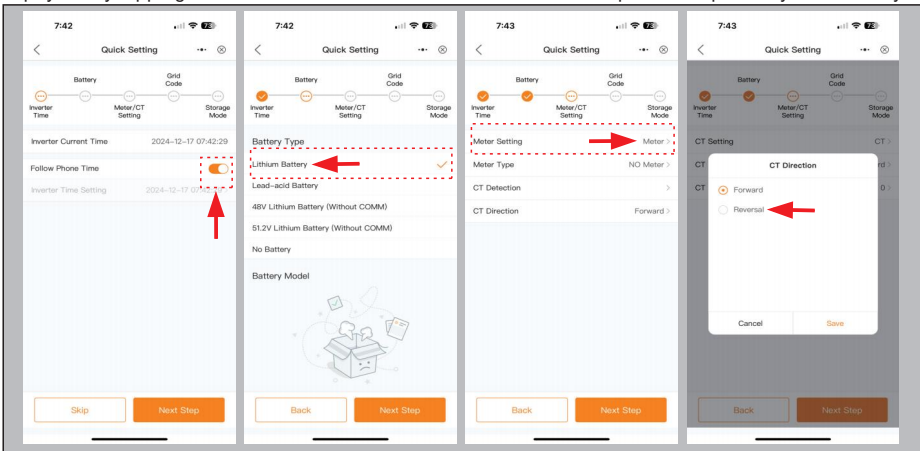

The inverter Grid Code is the grid interconnection profile by which the inverter will operate when it is connected to the grid. For systems installed in the United States, the base (default) profile is **UL-240V-18**. This grid profile is based on the IEEE 1547-2018 standard and is compliant with UL 1741 SB. Tap the standard at the top first to bring up the list of regions. The regions are organized alphabetically, then adjust according to the local power grid. You can then alter the trip point parameters by tapping the parameter, entering the desired value, and then tapping Save when finished. The Grid Neutral Connection setting should be set to Connected.

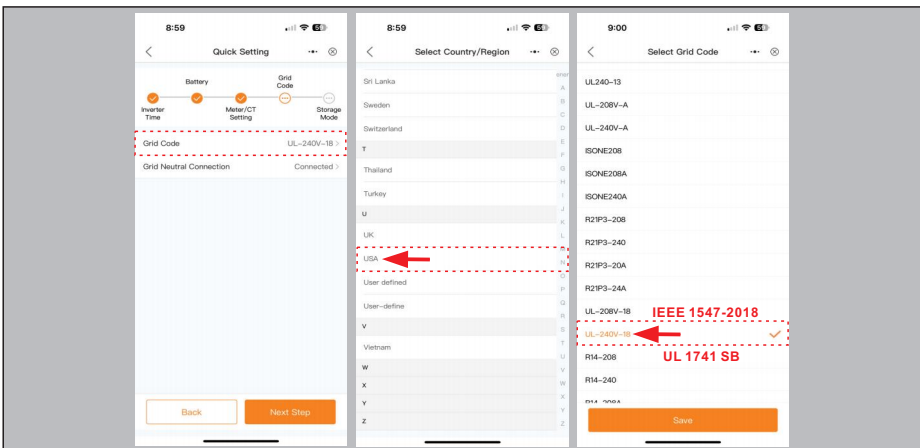

# 6. Commissioning

The *Storage Mode* is the energy storage operating mode of the inverter. Please see the logic tables on pages 17 through 19 for explanations on how the modes operate to determine which one you should select for each system. Self use mode prioritizes charging of the battery with excess PV power whereas Selling first mode prioritizes exporting excess PV power. Off grid mode should only be turned on for systems that are never connected to the grid, such as a cabin in the woods.

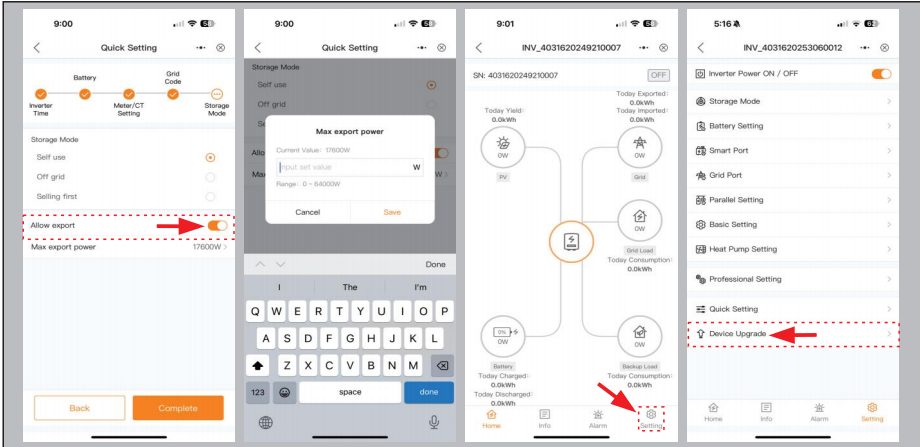

If you want to allow the inverter to export power to the grid, toggle on the Allow export setting and then set a maximum export value for the system. Tap Save and then tap Complete. You will now be at the main page. Tap Setting in the bottom right corner to go to the firmware updating menu.

## Upgrade the inverter firmware

Tap Device Upgrade at the bottom of the list. Then, tap **Check the update** for HMI. A message will either prompt you to download and upgrade the new firmware version or it will inform you that the firmware is on the most current version. Wait for the firmware to finish downloading and then initiate the upgrade. Leave the SolisCloud app open until the update is complete. It could take between 10 and 30 minutes to upgrade. Repeat the process for the DSP firmware. The total upgrade time can take up to 60 minutes. You will only need to upgrade once on-site. Firmware upgrades can be remotely pushed by the Solis service team if an upgrade is required in the future or if the local upgrades are unsuccessful.

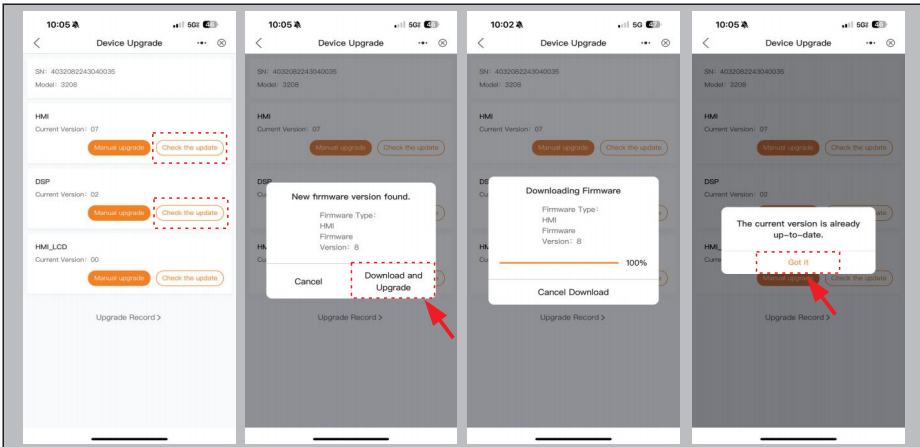

# 6. Commissioning

## Storage Mode Settings

Tap Storage Mode at the top of the list. **Self use** mode is the default. Enabling the **Batt Reserved** setting will ensure that the battery has power in case of a grid outage. While on-grid the battery will cycle from 100% to the Batt Reserved SOC% and will only go below that % if the system loses grid power. **Grid Peak shaving** allows for a set amount of grid power to be imported before the battery discharges to cover load demand. **Allow grid charge** allows the grid to be able to charge the battery if there is not enough PV. **Charge and discharge time slots** let you manually control when the battery charges and discharges.

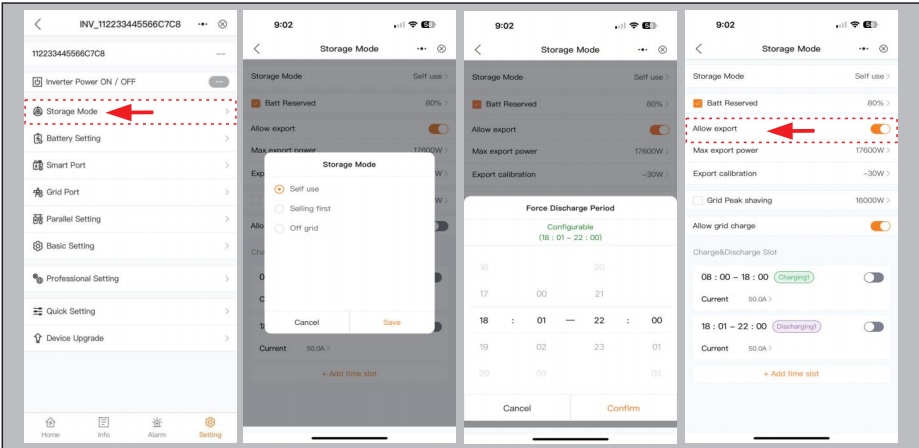

## Time of Use Settings (Time Charging/Discharging)

This function allows you to customize when the battery can charge/discharge power and at what power rate, established by a DC current (A) setting. If the slider switch is on, the inverter will only use this schedule to determine when to charge and discharge the battery. Set the **Charge Time Slot** and **Discharge Time Slot**, be sure there is no overlap between them. Tap + **Add Time** and then set the start and end times. During the time outside of the set windows and if the Time-of-Use toggle switch is off, the inverter will exercise the default logic for the mode, see pages 18 to 19. If **Allow Grid Charging** is turned on, the inverter will use grid power to charge the battery only under two circumstances: (1) the battery discharges to the **Force Charge SOC** set in the **Battery Settings** and (2) Time of Use is enabled and there is not enough available PV power during the charge window to meet the current rate that is established.



### NOTE:

**Allow grid charge** should be enabled for every system. The inverter will float charge the battery when there is not enough PV power available. This ensures the battery never drains past the point-of-no-return.

## Export Power Settings

The export power settings are found within the self-use mode settings. Toggling on the **Allow export** setting permits the inverter to export excess PV power to the grid. Set the **Max. export power** setting to the value you need. Set it to zero for no export. **Export calibration** compensates for measurement deviation. It is recommended to have it be -30W for zero export configuration.

# 6. Commissioning

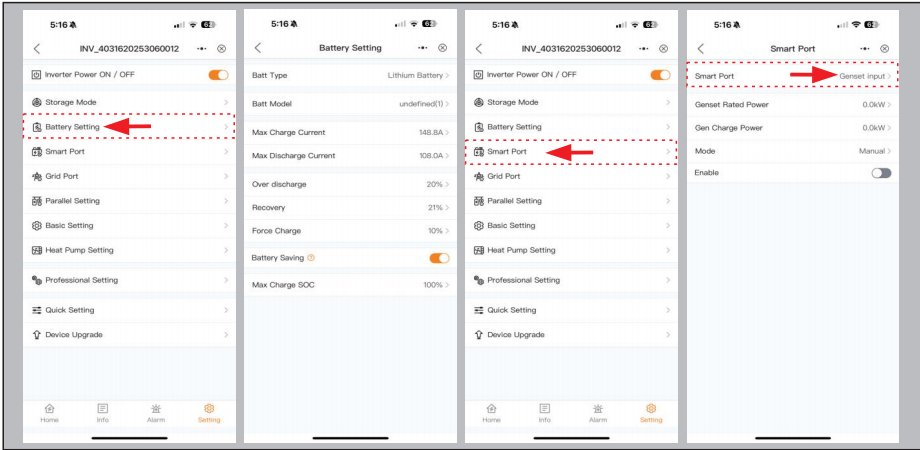

## Battery Settings

Go to the main settings menu. Tap Battery Setting. You can modify the battery type and model here.

**Max. charge and discharge** can be altered, but the BMS will always have final control over the battery so it may limit the inverter. The battery will discharge until it reaches the **Over Discharge SOC%**, then it will charge to the **Recovery SOC%**. If the battery is only allowed to charge with PV power, then it will trickle discharge from the Over discharge SOC% to the **Force Charge SOC%** before using some grid power to float charge the battery until there is enough PV power to charge. The inverter uses some power to operate. Turning on **Battery Saving** mode means the inverter will import power from the grid to cover its own needs instead of getting that power from the battery. **Max. Charge SOC%** is the upper limit that the battery can charge to. Force charge SOC% < Over discharge SOC% < Recovery SOC% or there could be abnormal operation.

## Smart Port Settings (Generator)

Tap Smart Port in the main Settings menu. If a generator is being connected to the inverter, first tap None and change and then change it to Genset Input. Set the Genset Rated Power, which is the size in kW of the generator. Then, set the Gen Charge Power or amount of generator power that the battery will be allowed to charge with. Finally, change the Mode to Automatic if you want the generator to start

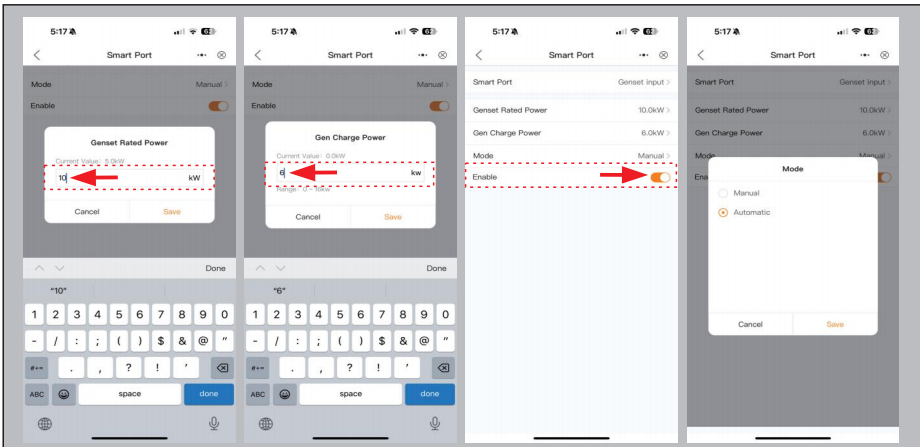

# 6. Commissioning

based on the battery SOC%. The **OFF** SOC% determines when the generator will be shut off by the inverter while in backup/off-grid mode. The **ON** SOC% determines when the generator will be turned on to charge the battery and supply the home loads. When this occurs, the PV power will become zero as to not back feed the generator. These SOC% values can be adjusted as needed.

## Smart Port Settings (AC-Coupling & Load Control)

If an AC-coupled PV system is being connected to the Smart Port of the inverter, set the Smart Port to **AC Coupled**. The **OFF** and **ON** SOC values dictate when the inverter will turn the AC Coupled system on and off while in backup/off-grid mode. If a large load such as an EV charger, air conditioner, or subpanel with non-essential loads is being connected to the Smart Port of the inverter, set the Smart Port to **Smart load output**. This load can be controlled when the system in backup/off-grid mode. The **ON** and **OFF** SOC values establish when the load will be energized and when it will not. The toggle switch for **On grid always on** should be enabled if the load is to always have power while on-grid. If the load is to be shed anytime there is an outage regardless of available power, turn on **Off grid always off**.

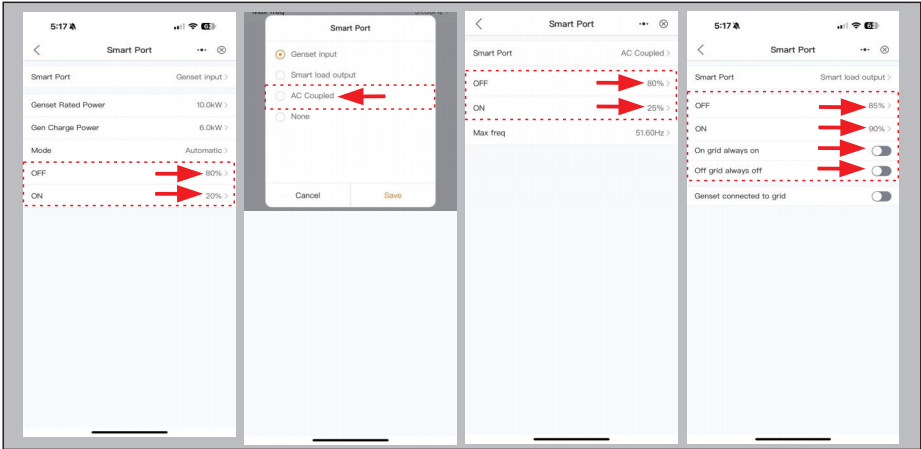

## Paralleling Steps

If there are two or more Solis hybrid inverters connected together with communication cables, Tap **Parallel Setting** and then turn on the **Parallel System** toggle switch. The first inverter should be set to

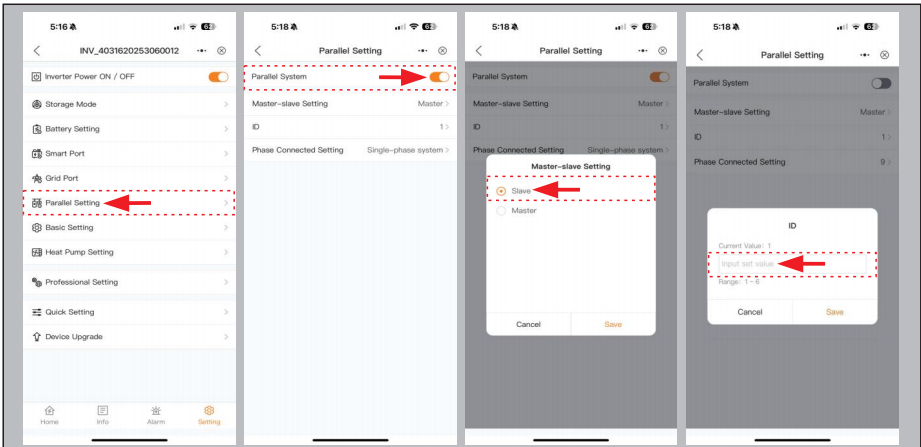

# 6. Commissioning

Master and all of the other inverters should be set to Slave. The Master should have an ID of 1 and the slaves should be numbered 2-6.

### Professional Settings: Device Settings: Backup and Meter Settings

The last few key settings can be found in the Device Setting menu. From the main settings menu, tap Professional Setting, then tap Device Setting. Here the **Backup Port Reference Setting** can be verified at 240VAC. There is a toggle switch for backup **Voltage Droop** along with a **Minimum Droop Voltage** setting. Ensure that the **Backup Reference Frequency Setting** is set to 50Hz/60Hz. Meter Setting can be changed from Meter to CT if CTs are directly connected to the inverter. Meter type should be set to No Meter if CTs are directly connected. Most installations will need to set Meter/CT installation location to Grid side. If the CTs were physically installed backwards, the CT Direction setting allows you to electronically reverse the CTs so a technician does not need to physically reverse them.

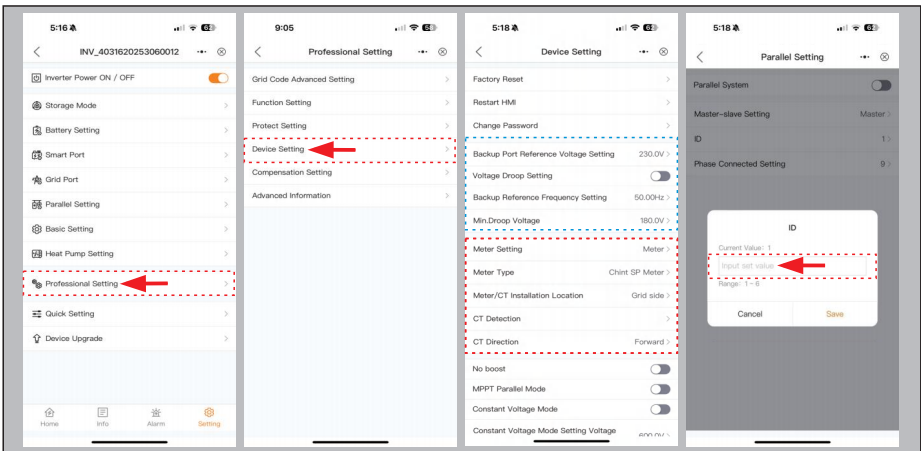

### Miscellaneous Settings

Within Professional Setting > Device Setting you will find an option to Factory Reset the inverter. Restart HMI will reboot the LCD screen. Change Password is to change the login password for the inverter Bluetooth tool.

### Inverter settings configuration are now complete

#### Turn the inverter ON

Now that the settings are done, turn on the inverter DC switch. The system will begin to generate PV power after about five minutes provided there are no persistent alarms. The main screen of the Bluetooth tool and the inverter LCD screen both provide an overview of the system behavior. It can quickly be determined if the battery is properly communicating or not and what the SOC is. If you are looking at the plant on SolisCloud remote view, the data is about 5 minutes behind since the logger sends data once every five minutes. If you are using SolisCloud Bluetooth tool local view, the data is in real-time with marginal delay.

If you notice the inverter is taking longer than five minutes to start up. Check the alarm tab, instructions are on the next page.

# 6. Commissioning

At the bottom of the main page are four submenus: Home, Info, Settings, and More. The Info page breaks down into four categories: Inverter, Battery, Grid, and Load.

**Inverter:** inverter power production history, PV voltages and currents, inverter info

(serial number, model number, and firmware version), grid code, and alarm code history

**Battery:** battery model and status, battery voltage, current, SOC, SOH, and historical data

**Grid:** Active power, voltage, current, historical power produced, imported and exported, grid AC voltage and frequency

**Load:** power, voltage, current of the backup (load) port

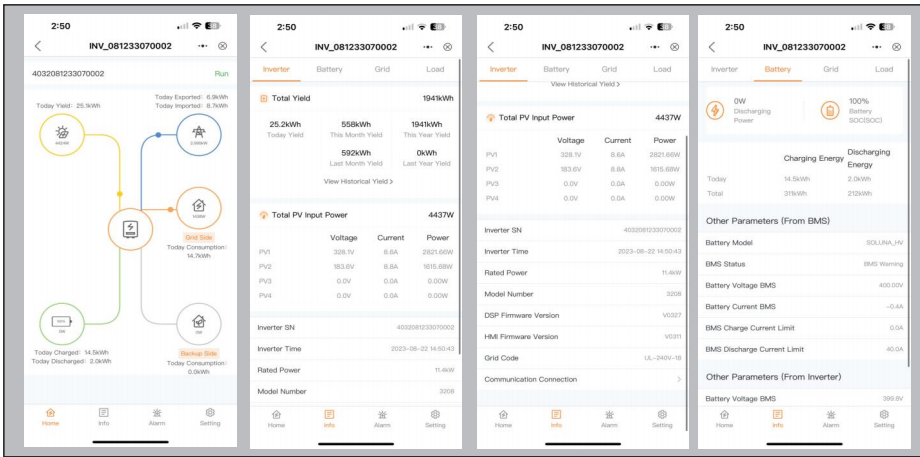

## Alarm History

It is recommended to check the alarm history as the final step of the commissioning process, excluding creating a site on SolisCloud for the system. Tap **Alarm** and then tap **Historical Alarm** to view the full alarm history. Each alarm will have a date and time stamp as well as a suggestion on how to handle the alarm. The next section goes over troubleshooting and you can always contact Solis USA technical support with any questions or concerns.

## Finishing the Commissioning Process

The inverter commissioning process has now been completed. It is recommended to monitor the system closely over the next week to ensure that everything is working as it should. Please refer to the Solis data logger manual for assistance with registering a new plant on SolisCloud.

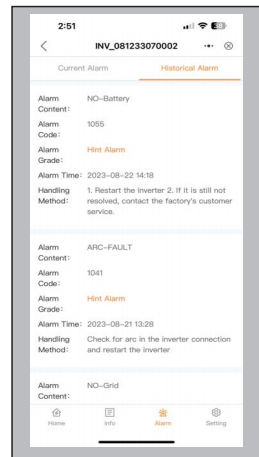

# 6. Commissioning

## 6.5 SolisCloud Bluetooth Tool Settings Tree

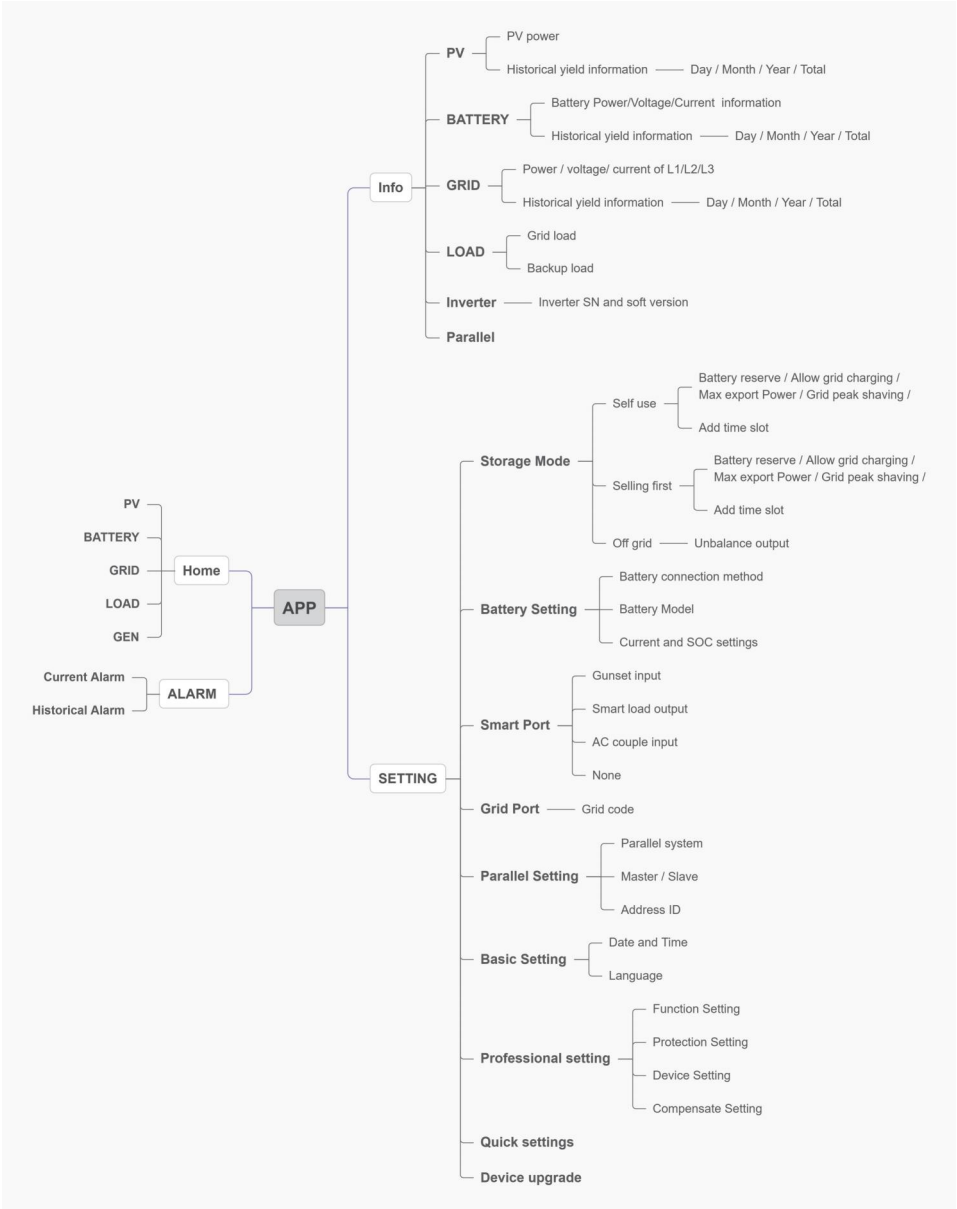

# 6. Commissioning

## 6.6 LCD Screen Settings Tree

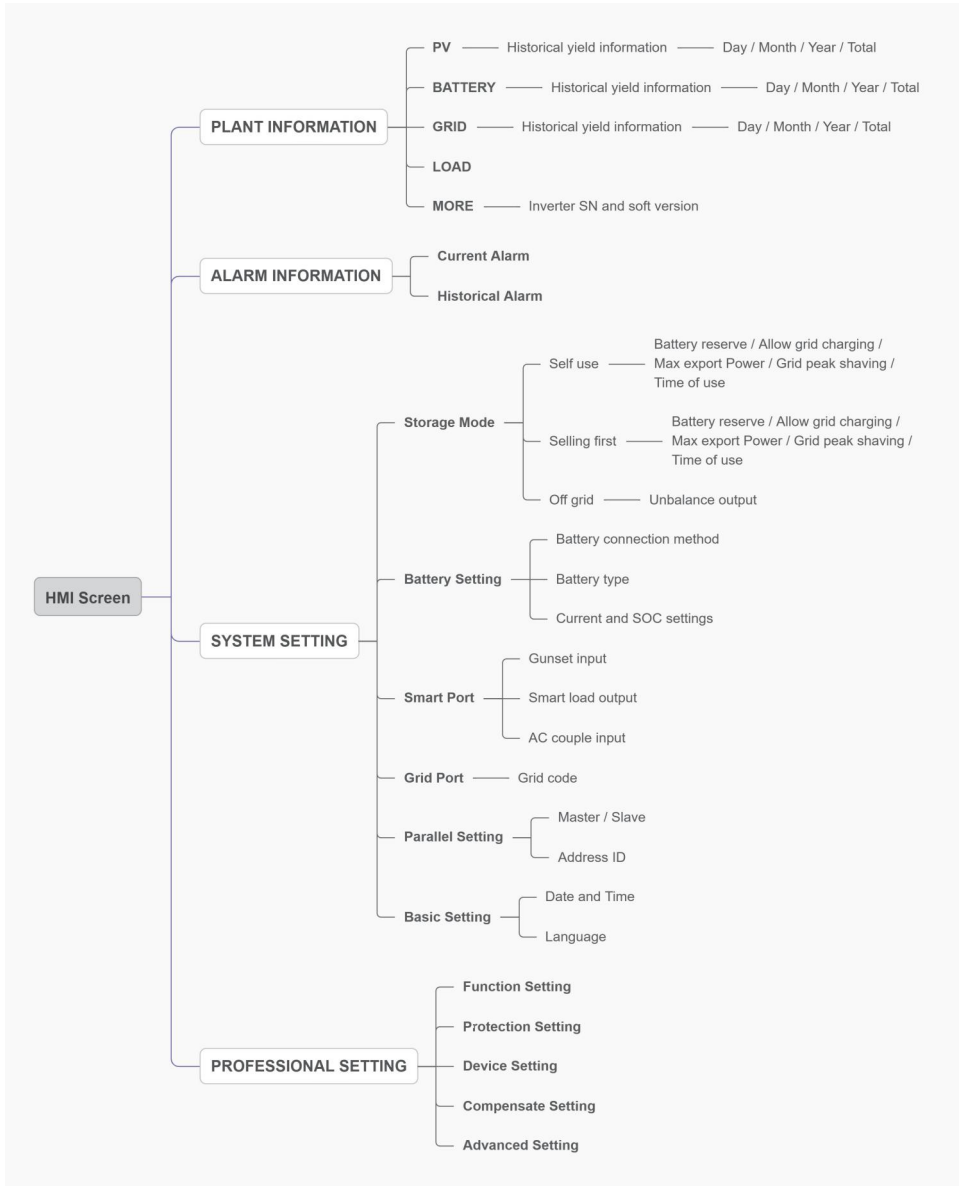

# 7. Troubleshooting

---

## Solis Latin America Technical Support Contact Information

Phone Number: **+52 81 3434 2092**

Email: **support@solislatam.freshdesk.com**

If you are having an issue with your system, please contact Solis Technical Support for assistance. If the inverter is having an issue, it will show it in one of the following ways: (1) the Inverter (circle) LED indicator light will flash orange. (2) the inverter status will be an alarm code (3) an alarm code will display on SolisCloud or (4) the inverter will simply be off. The next several pages explain how to troubleshoot each alarm code. If it is suspected that the issue is coming from the DC side of the system, it is recommended to turn the inverter off so that the PV strings can be more safely tested.

## 7.1 Inverter Shutdown Procedure

Step 1. Turn off the AC disconnect switch to disable AC power to the inverter

Step 2. Push in the RSD Initiation Switch and then turn off the DC switch of the inverter

Step 3. Turn off the battery breaker on the battery BMS

Step 4. Use a multimeter to verify that the battery and AC voltages are 0V. If RSD is being used, the PV string voltages should be at safety levels

## 7.2 Inverter Maintenance

Solis S6 hybrid inverter does not require any regular maintenance. However, keeping the heatsink clean will ensure the inverter is able to dissipate heat, increasing the life span of the inverter. Any grease smudges on the inverter chassis can be cleaned off with soap and water.



### **CAUTION:**

Do not touch the surface of the inverter it is operating. Some parts may be hot and could cause a minor burn. Turn off the inverter (refer to Section 7.1) and let it cool down before you do any maintenance or cleaning of it.

The LED status indicator lights can be cleaned with damp cloth if they are too dirty to be read.



### **Note:**

Never use any solvents, abrasives, or corrosive materials to clean the inverter.

The inverter has been designed in accordance with international standards for safety and electromagnetic compatibility requirements. Before being shipped from the manufacturing center, the inverter is subjected to multiple tests to ensure operation reliability.

If you are not able to resolve the alarm code using the troubleshooting steps, or if the alarm code you are seeing is not listed, please contact Solis US Technical support. Use the Bluetooth tool, go to the Info page and then to the Inverter tab. Scroll down and tap Alarm History and then screen shot or write down the alarms as well as the dates and times the alarms were recorded. Please also take note of the inverter model number, serial number, and internal transmitter type.

# 7. Troubleshooting

## 7.3 Inverter Alarm Codes

Message Name	Information Description	Troubleshooting Suggestion
BatName-FAIL	Wrong battery brand selection	1. Confirm whether the battery model selection is consistent with the actual one.
CAN Fail	CAN Fail	1. Can failure is a failure of communication between inverter and battery. Check cable conditions. Check to ensure you have it plugged in on the CAN port of the battery and inverter. Check that you are using the right cable. Some batteries require a special battery from the battery manufacturer.
OV-Vbatt	Battery undervoltage detected	1. Verify battery voltage is within standards. Measure battery voltage at inverter connection point. Contact your battery manufacturer for further service.
UN-Vbatt	Battery overvoltage detected	1. Restart the system and check if the fault persists. If it is still not eliminated, please contact the manufacturer's customer service.
Fan Alarm	Fan alarm	1. Check if the internal fan is working correctly or jammed.
OV-DC01 (1020 DATA:0001)	DC 1 input overvoltage	1. Check if the PV voltage is abnormal 2. Restart the system, confirm that the fault continues
OV-DC02 (1020 DATA:0002)	DC 2 input overvoltage	
OV-BUS (1021 DATA:0000)	DC bus overvoltage	1. Restart the system, confirm that the fault continues.
UN-BUS01 (1023 DATA:0001)	DC bus undervoltage	
UNB-BUS (1022 DATA:0000)	DC bus unbalanced voltage	
UN-BUS02 (1023 DATA:0002)	Abnormal detection of DC bus voltage	
DC-INTF. (1027 DATA:0000)	DC hardware overcurrent (1, 2, 3, 4)	1. Check if the DC wires are connected correctly without loose connection.
OV-G-I (1018 DATA:0000)	A phase RMS value overcurrent	1. Confirm that the grid is abnormal. 2. Confirm that the AC cable connection is not abnormal. 3. Restart the system, confirm that the fault continues.
OV-DCA-I (1025 DATA:0000)	DC 1 average overcurrent	1. Restart the system, confirm that the fault continues.
OV-DCB-I (1026 DATA:0000)	DC 2 average overcurrent	
GRID-INTF. (1030 DATA:0000)	AC hardware overcurrent (abc phase)	

# 7. Troubleshooting

Message Name	Information Description	Troubleshooting Suggestion
Off	Control device to shutdown	1. Turn on the device in the ON/OFF Setting.
LmtByEPM	The device's output is under controlled	<ol style="list-style-type: none"> <li>1. Confirm whether the inverter is connected to an external EPM/meter to prevent reverse current.</li> <li>2. Confirm whether the inverter is controlled by an external third-party device.</li> <li>3. Confirm whether the power setting of the inverter power control is limited.</li> <li>4. Verify settings in section 6.6.7 and check your meter readings.</li> </ol>
LmtByDRM	DRM Function ON	1. No need to deal with it.
LmtByTemp	Over temperature power limited	1. No need to deal with it, the device is in normal operation.
LmtByFreq	Frequency power limited	
LmtByVg	The device is in the Volt-Watt mode	<ol style="list-style-type: none"> <li>1. Due to the requirements of local safety regulations, when the grid voltage is high, the Volt-watt working mode is triggered, which generally does not need to be dealt with.</li> <li>2. Inverter factory test errors causing this mode to open, if you need to close, you can close this mode in LCD, set the process: Main menu → Advanced Settings → Password 0010 → STD mode settings → Working Mode → Working mode: NULL → Save and exit.</li> </ol>
LmtByVar	The device is in the Volt-Var mode of operation	<ol style="list-style-type: none"> <li>1. Due to the requirements of local safety regulations, when the grid voltage is high, the Volt-watt working mode is triggered, which generally does not need to be dealt with.</li> <li>2. Inverter factory test errors causing this mode to open, if you need to close, you can close this mode in LCD, set the process: Main menu → Advanced Settings → Password 0010 → STD mode settings → Working Mode → Working mode: NULL → Save and exit.</li> </ol>
LmtByUnFr	Under frequency limit	1. No need to deal with it.
Standby	Bypass run	
StandbySynoch	Off grid status to On grid status	
GridToLoad	Grid to load	

# 7. Troubleshooting

Message Name	Information Description	Troubleshooting Suggestion
DCInj-FAULT (1037 DATA:0000)	The current DC component exceeds the limit	<ol style="list-style-type: none"> <li>1. Confirm that the grid is abnormal.</li> <li>2. Confirm that the AC cable connection is not abnormal.</li> <li>3. Restart the system, confirm that the fault continues.</li> </ol>
IGBT-OV-I (1048 DATA:0000)	IGBT overcurrent	<ol style="list-style-type: none"> <li>1. Restart the system, confirm that the fault continues.</li> </ol>
OV-TEM (1032 DATA:0000)	Module over temperature	<ol style="list-style-type: none"> <li>1. Check whether the surrounding environment of the inverter has poor heat dissipation.</li> <li>2. Confirm whether the product installation meets the requirements.</li> </ol>
RelayChk-FAIL (1035 DATA:0000)	Relay failure	<ol style="list-style-type: none"> <li>1. Restart the system, confirm that the fault continues.</li> </ol>
UN-TEM (103A DATA:0000)	Low temperature protection	<ol style="list-style-type: none"> <li>1. Check the working environment temperature of the inverter.</li> <li>2. Restart the system to confirm if the fault continues.</li> </ol>
PV ISO-PRO01 (1033 DATA:0001)	PV negative ground fault	<ol style="list-style-type: none"> <li>1. Check whether the PV strings have insulation problems.</li> <li>2. Check whether the PV cable is damaged.</li> </ol>
PV ISO-PRO02 (1033 DATA:0002)	PV positive ground fault	
12Power-FAULT (1038 DATA:0000)	12V undervoltage failure	<ol style="list-style-type: none"> <li>1. Check current leakage to ground. Verify your grounding. Verify all wires are in good condition and not leaking current to ground.</li> </ol>
ILeak-PRO01 (1034 DATA:0001)	Leakage current failure 01 (30mA)	
ILeak-PRO02 (1034 DATA:0002)	Leakage current failure 02 (60mA)	
ILeak-PRO03 (1034 DATA:0003)	Leakage current failure 03 (150mA)	
ILeak-PRO04 (1034 DATA:0004)	Leakage current failure 04	
ILeak_Check (1039 DATA:0000)	Leakage current sensor failure	
GRID-INTF02 (1046 DATA:0000)	Power grid disturbance 02	
OV-Vbatt-H/ OV-BUS-H (1051 DATA:0000)	Battery overvoltage hardware failure / VBUS	<ol style="list-style-type: none"> <li>1. Check if the battery circuit breaker is tripping.</li> <li>2. Check if the battery is damaged.</li> </ol>

# 7. Troubleshooting

Message Name	Information Description	Troubleshooting Suggestion
Surge Alarm	On-site grid surge	1. Grid side fault, restart the device. If it is still not eliminated, please contact the manufacturer's customer service.
OV-G-V01	Grid voltage exceeds the upper voltage range	<ol style="list-style-type: none"> <li>1. Confirm whether the power grid is abnormal.</li> <li>2. Confirm that the AC cable is properly connected.</li> <li>3. Restart the system and check if the fault persists.</li> </ol>
UN-G-V01	Grid voltage exceeds the lower voltage range	
OV-G-F01	Grid frequency exceeds the upper frequency range	
UN-G-F01	Grid frequency exceeds the lower frequency range	
G-PHASE	Unbalanced grid voltage	
G-F-GLU	Grid voltage frequency fluctuation	
NO-Grid	No grid	
OV-G-V02	Grid transient overvoltage	
OV-G-V03	Grid transient overvoltage	1. Restart the system, confirm if that the fault continues.
IGFOL-F	Grid current tracking failure	<ol style="list-style-type: none"> <li>1. Confirm whether the power grid is abnormal.</li> <li>2. Confirm that the AC cable is properly connected.</li> <li>3. Restart the system and check if the fault persists.</li> </ol>
OV-G-V05	Grid voltage RMS instantaneous overvoltage fault	
OV-G-V04	Grid voltage exceeds the upper voltage range	
UN-G-V02	Grid voltage exceeds the lower voltage range	
OV-G-F02	Grid frequency exceeds the upper frequency range	
UN-G-F02	Grid frequency exceeds the lower frequency range	
NO-Battery	Battery is not connected	<ol style="list-style-type: none"> <li>1. Check on information page 1 – Verify the battery voltage is within standards.</li> <li>2. Measure battery voltage at plug.</li> </ol>
OV-Vbackup	Inverting overvoltage	<ol style="list-style-type: none"> <li>1. Check whether the backup port wiring is normal</li> <li>2. Restart the system, confirm that the fault continues.</li> </ol>
Over-Load	Load overload fault	1. Backup load power is too large, or some inductive load startup power is too large, need to remove some backup load, or remove the inductive load on the backup.

# 7. Troubleshooting

Message Name	Information Description	Troubleshooting Suggestion
OV-ILLC (1052 DATA:0000)	LLC hardware overcurrent	1. Check whether the backup load is overloaded. 2. Restart the system, confirm that the fault continues.
INI-FAULT (1031 DATA:0000)	AD zero drift overlink	1. Restart the system, confirm that the fault continues.
DSP-B-FAULT (1036 DATA:0000)	The master-slave DSP communication is abnormal	
AFCI-Check (1040 DATA:0000)	AFCI self-test failure	
ARC- FAULT (1041 DATA:0000)	AFCI failure	1. Verify connections are tight within your PV system. Arc fault settings can be changed in advanced settings if further adjustment is necessary.



**NOTE:**

If the inverter displays any alarm messages listed in Table 7.1, please turn off the inverter and wait for 5 minutes before restarting it . If the alarm persists, please contact Solis after-sales service +52 81 3434 2092 or email [support@solislatam.freshdesk.com](mailto:support@solislatam.freshdesk.com)

If you have any technical problems with the hybrid system, please contact Solis after-sales service. We recommend gathering the following information before making contact in order to get a quicker resolution.

Item	Supplemental Information
Inverter serial number (SN)	Serial number can be found on the spec label
Inverter Firmware Version	A six character number that can be found in the information section of the inverter interface page - requires Bluetooth connection
Alarm history	Codes found in the Inverter section of the interface
DC voltages	Use a multimeter to measure the voltages
Detailed description of the problem	Frequency of the occurrence and any other relevant details about the issue
Battery serial number and Firmware version	Consult the battery product manual to determine how to collect this information
Is the system reporting to SolisCloud?	Yes/No - if yes, what is the site ID?
Take pictures showing all the cable connections in the system (Videos preferred)	If this is possible, it will help us to troubleshoot

# 7. Troubleshooting

---

## 7.4 Inverter Firmware

Solis inverters have a few different types of firmware that should all be on the latest version. If one site has several inverters installed, they should all be on the same versions to prevent errors.

**Solis Inverter Firmware Types:**

**DSP:** Digital Signal Processor

**HMI:** Human-Machine-Interface

**AFCI:** Arc-Fault-Circuit Interruption

To check which version the inverter is currently on, first connect to the inverter with Bluetooth. Go to the Information tab and be sure that you are on the Inverter tab. Scroll to the bottom and look for the DSP and HMI versions. The AFCI and SolisHub current versions can only be upgraded remotely with the assistance of Solis Technical Support. However, new AFCI and SolisHub firmware versions are released far less frequently than DSP and HMI. It is likely that the inverter does not need to have AFCI and SolisHub firmware upgraded, but best to check with Solis Support.

There are three methods of updating the inverter firmware: (1) remotely (2) locally with Bluetooth, and (3) locally with a tool.

### 7.4.1 Remote Firmware Updating

The inverter firmware can be updated remotely but only if the inverter has a Solis data logger connected directly to it. The logger must also be connected to the internet. Once that has been done, please call or email Solis after-sales-service to request the firmware be updated remotely.

**Please note:** Only Solis Tech Support can update inverters remotely.

### 7.4.2 Local Firmware Updating Through Bluetooth

The recommended method for updating the inverter firmware is locally using the SolisCloud Bluetooth tool. The steps for this process can be found on pages 61-62 (Step 3 of Commissioning). It is highly advisable to upgrade the inverter firmware during the commissioning process before configuring the settings.

### 7.4.3 Local Firmware Updating with the Solis Upgrade Tool

If the upgrades are not going through using the first two methods, the inverter can be upgraded using a proprietary Solis Upgrade Tool. Please contact Solis Technical Support to request an Update Tool be mailed to you. You will also need to request the firmware files themselves. Solis Technical Support can guide you through the process.



**IMPORTANT:**

If there are multiple inverters in parallel, please connect one data logger to each inverter to ensure that firmware can be updated remotely. Slave firmware cannot be updated through a logger connected to the master.

All inverters in the same system must be on the same firmware version.

# 8. Appendix

## 8.1 Default Setting for IEEE1547-2018 (UL-240V-18)

Parameter	Adjustment Range (p.u.)	Default (p.u.)	Description
OV-G-V01	$1.10 < V \leq 1.21$	1.10 p.u.	Set grid over-voltage protection 01 value
OV-G-V01-T	0.1-13 S	13 S	Grid over-voltage protection 01 trip time
OV-G-V02	$1.20 < V \leq 1.30$	1.20 p.u.	Set grid over-voltage protection 02 value
OV-G-V02-T	0.1-5 S	0.16 S	Grid over-voltage protection 02 trip time
UN-G-V01	$0.5 \leq V < 0.88$	0.88 p.u.	Set grid under-voltage protection 01 value
UN-G-V01-T	2.0-50 Sec.	21 S	Grid under-voltage protection 01 trip time
UN-G-V02	$0.45 \leq V < 0.70$	0.5 p.u.	Set grid under-voltage protection 02 value
UN-G-V02-T	0.16-21 S	2 S	Grid under-voltage protection 02 trip time
UN-G-V03	$0.050 < V < 0.5$	0.5 p.u.	Set grid under-voltage protection 03 value
UN-G-V03-T	0.16-21 S	2 S	Grid under-voltage protection 03 trip time
OV-G-F01	$60.5 < F < 66$ Hz	61.2 Hz	Set grid over-frequency protection 01 value
OV-G-F01-T	180-1000 S	300 S	Set grid over-frequency protection 01 trip time
OV-G-F02	$61.2 < F < 66$ Hz	62 Hz	Set grid over-frequency protection 02 value
OV-G-F02-T	0.16-1000 S	0.16 S	Set grid over-frequency protection 02 trip time
UN-G-F01	$50 < F < 59$ Hz	58.5 Hz	Set grid under-frequency protection 01 value
UN-G-F01-T	180-1000 S	300 S	Set grid under-frequency protection 01 trip time
UN-G-F02	$50 < F < 58$ Hz	56.5 Hz	Set grid under-frequency protection 02 value
UN-G-F02-T	0.16-1000 S	0.16 S	Set grid under-frequency protection 02 trip time
Reconnection Voltage	$0.88 \leq V \leq 0.95$ $1.05 \leq V \leq 1.06$	0.917 p.u. 1.05 p.u.	Set grid recovery voltage range after grid fault
Reconnection Frequency	$59 \leq F \leq 59.9$ $60.1 \leq F \leq 61$	59.5 Hz 60.1 Hz	Set grid recovery frequency range after grid fault
Reconnection Time after Fault	0-600 S	300 S	Set reconnection time after a fault is cleared
Ramp-up Slew Rate	0.10-100%	100% W/S	Set Ramp-up power slew rate during start-up
Reconnect Slew Rate	0.10-100%	0.33% W/S	Set Ramp-up power slew rate during reconnect

# 8. Appendix

Parameter	Adjustment Range (p.u.)	Default (p.u.)	Description
Volt Watt P3Tau	0.5-60 S	10 S	Set the time to ramp up to 90% of the new active power target in response to the change in voltage
Volt Var Q3Tau	1-90 S	5 S	Set the time to ramp up to 90% of the new reactive power target in response to the change in voltage
Dead Band-OF	60.017-61 Hz	60.036Hz	Set OV frequency start dead band for power derate
Droop-OF	2-5 %	5 %	Set OV frequency derate droop slope
Response Time	0.2-10 S	5 S	Set frequency derate response time
Dead Band-UF	59-59.983 Hz	59.964 Hz	Set UN frequency start dead band for power derate
Droop-UF	2-5 %	5 %	Set UN frequency derate droop slope
Droop Pmin	0-100 %	0 %	Set frequency droop P minimum
Volt-Watt	Enabled/ Disabled	Enabled	Set Volt - Watt function
V1	Hybrid: $0.40 \leq V \leq 1.00$ Grid-tied: $0.90 \leq V \leq 1.30$	Hybrid: 0.5 p.u. Grid-tied: p.u.	Set grid voltage V1 limit for Volt-Watt control
P1	0-100 % Pn	100% Pn	Set power P1 for Volt-Watt control
V2	Hybrid: $0.60 \leq V \leq 1.05$ Grid-tied: $1.00 \leq V \leq 1.35$	Hybrid: 0.7 p.u. Grid-tied: p.u.	Set grid voltage V2 limit for Volt-Watt control
P2	0-100 % Pn	100% Pn	Set power P2 for Volt-Watt control
V3	$1.05 \leq V \leq 1.09$	1.06 p.u.	Set grid voltage V3 limit for Volt-Watt control
P3	0-100 % Pn	100% Pn	Set power P3 for Volt-Watt control
V4	$1.06 \leq V \leq 1.10$	1.10 p.u.	Set grid voltage V4 limit for Volt-Watt control
P4	0-100 % Pn	20% Pn	Set power P4 for Volt-Watt control
Volt-Var	Enabled/ Disabled	Enable	Set Volt-Var function
V1	$0.77 \leq V \leq 1.03$	0.92 p.u.	Set grid voltage V1 limit for Volt-Var control
Q1	$0-60\% S_n$	+44% Sn	Set reactive power Q1 for Volt-Var control
V2	$0.92 \leq V \leq 1.05$	0.98 p.u.	Set grid voltage V2 limit for Volt-Var control
Q2	$-60-60\% S_n$	0% Sn	Set reactive power Q2 for Volt-Var control
V3	$0.95 \leq V \leq 1.08$	1.02 p.u.	Set grid voltage V3 limit for Volt-Var control
Q3	$-60-60\% S_n$	0% Sn	Set reactive power Q3 for Volt-Var control
V4	$0.97 \leq V \leq 1.23$	1.08 p.u.	Set grid voltage V4 limit for Volt-Var control
Q4	$-60-0\% S_n$	-44% Sn	Set reactive power Q4 for Volt-Var control
Fixed PF	-0.8 -+0.8	1	Set Fixed Power Factor limit
Reactive Power	-60 -60 %	0%	Set Reactive Power level

# 8. Appendix

---

## 8.2 Data Collection and Storage

In order to improve our products and provide you with higher quality services, this device has a built-in data logging module for collecting relevant information during operation (such as power generation data, fault data)

**Commitment:**

1. We will only collect, use and process your device information for the purpose of improving our products and services.
2. We will take all reasonable and feasible measures to ensure that no irrelevant information is collected and we will protect your device information.
3. We will not share, transfer or disclose the collected device information with any company, organization or individual.
4. When we stop operating products or services, we will stop collecting information from your devices.  
information in a timely manner.
5. If you do not want to provide such information, you can notify our company to turn off this function, which will not affect your normal use of other functions of the product.

# 8. Appendix

## 8.3 Use-Case Scenario Diagrams

There are a wide variety of potential use-cases that the S6-EH2P(10-18)K03-SV-YD-L hybrid inverter series can fit into. The diagrams on the following pages show the possibilities and limitations of this inverter. These are meant to serve as examples of what the inverter can and cannot do.

### Maximum Export with Both PV Direct and AC-Coupled PV (ACPV) on the Smart Port

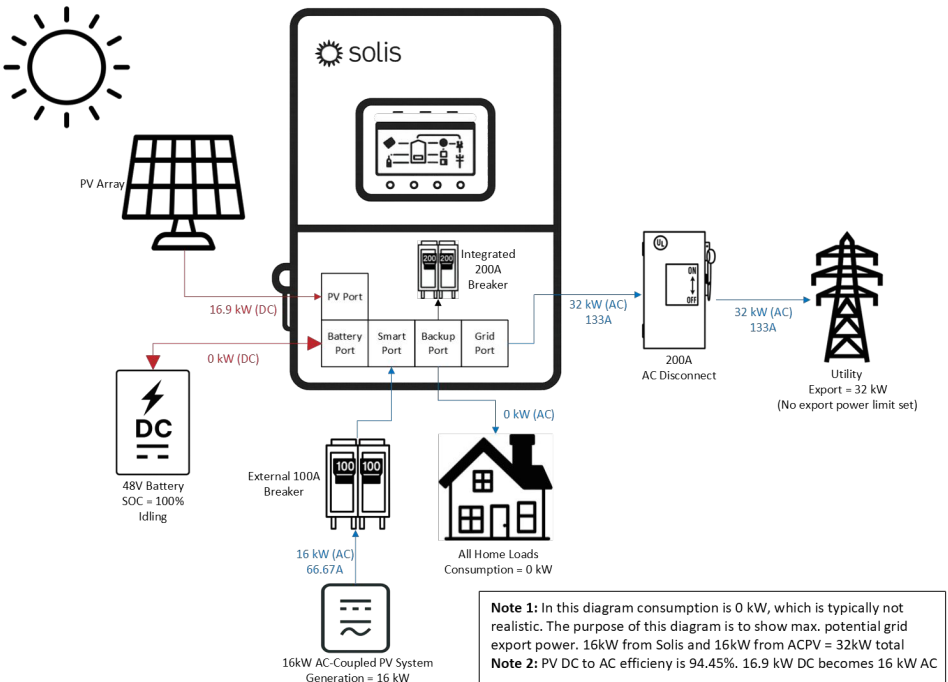

Here the inverter has an oversized PV system connected directly to the PV ports such that when in full sun it is producing 16kW AC. There is also an ACPV system connected to the Smart Port of the inverter. While on-grid, a single inverter system is capable of exporting a maximum of 32kW to the grid. This is assuming the load consumption is 0kW and the battery is fully charged.

#### Limitations of Connecting an AC-Coupled (ACPV) System:

1. 16kW AC is the maximum sized ACPV system that can be connected to the Smart Port.
2. ACPV cannot be connected to the backup side of the inverter.
3. If ACPV is being connected to the grid-side of the inverter, there is no limitation on the size of the system; however, the ACPV system will not be supported in backup mode.

# 8. Appendix

## AC-Coupled PV and Generator Both in the Same System

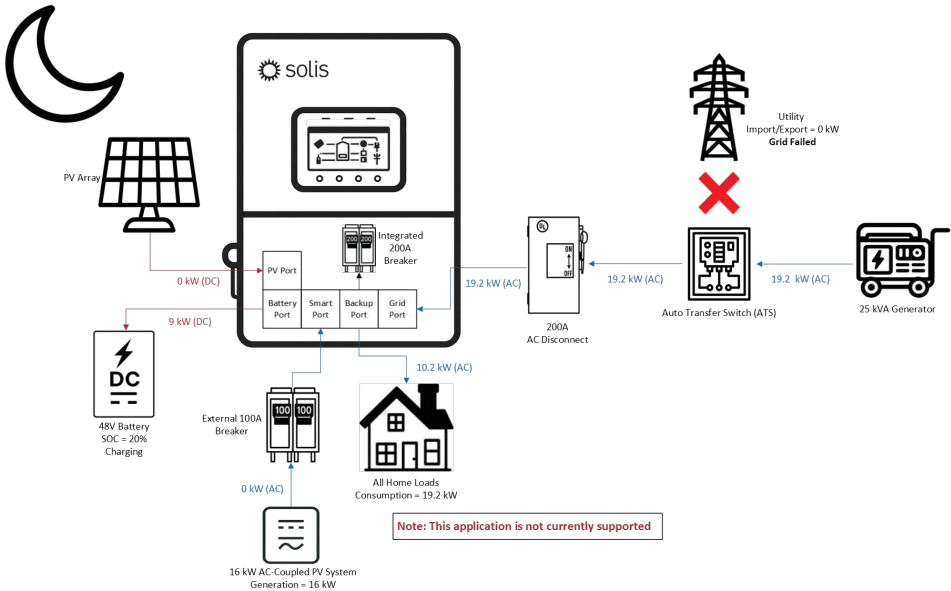

**This system configuration is not supported.** The purpose of this diagram is to show the specific limitations with respect to having both AC-coupled PV (ACPV) and a generator connected in the same system.

### Limitations to using ACPV and a Generator in the Same System:

1. Only ACPV or generator can be connected to the Smart Port at a time, never both.
2. If ACPV is connected to the smart port, a generator cannot be connected to the grid-side of the system using an external ATS (as shown in the diagram above).
3. Neither the ACPV nor the generator can be connected to the backup-side of the inverter
4. The generator can either be connected to the grid-side of the inverter or to the Smart Port, but if it gets connected to the Smart Port then the ACPV must be installed on the grid-side of the inverter.

# 8. Appendix

## Generator Connected to the Smart Port (Backup/Off-Grid Mode)

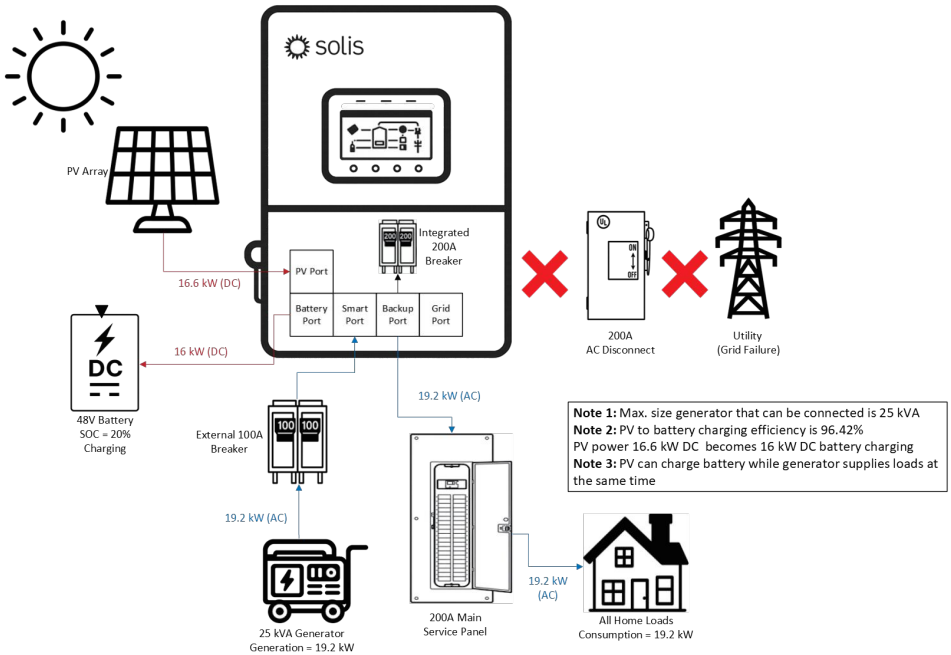

When a generator is connected to the Smart Port of the inverter, the inverter is capable of supporting the generator with PV and battery power at the same time the generator is running. The generator can supply power to the home loads while the PV recharges the battery. Conversely, the generator can be the one charging the batteries and supporting the home loads should it be nighttime or heavily clouded weather where PV is at/near 0 kW.

### Limitations of Generator to the Smart Port:

1. 25 kVA is the maximum sized generator that can be connected to the Smart Port.
2. If a generator is connected to the Smart Port, there can be no ACPV connected as well. Only one or the other is allowed, but never both at the same time.
3. The generator must support two-wire dry contact for start/stop control of the generator by the inverter.
4. Only gas-powered generators can be connected to the Smart Port. Do not connect any other type of power producing equipment to the Smart Port besides a generator or an AC-coupled (ACPV) system.

# 8. Appendix

## EV Charger (Heavy Load) Connected to the Smart Port

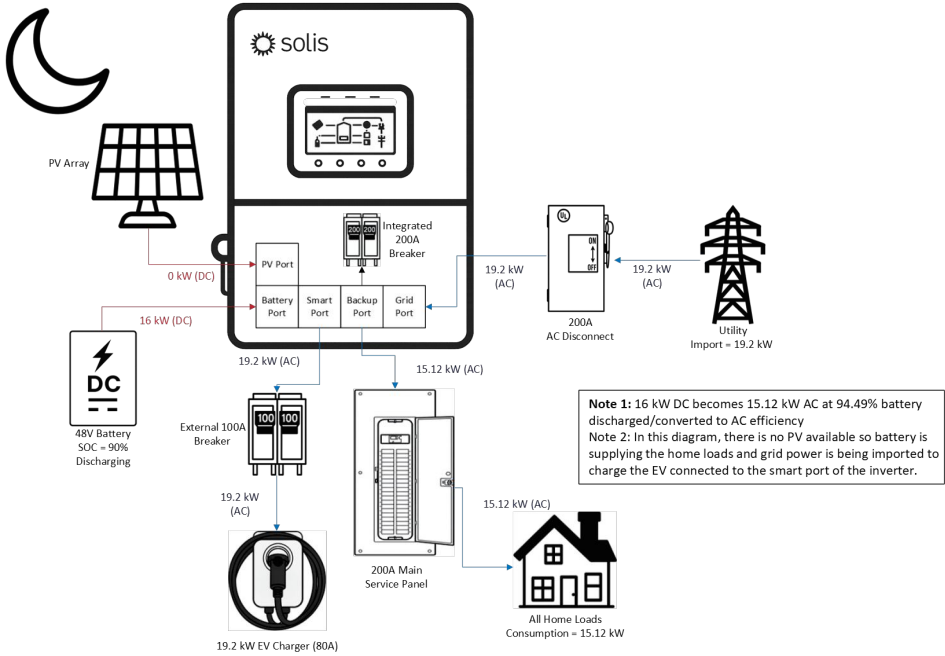

Besides an ACPV system or a generator, you can also connect a large heavy load to the Smart Port. This load will be supported when the system is in backup/off-grid so long as there is enough PV and battery power to support it. During commissioning, you would set a battery state-of-charge (SOC) percentage limit at which point the Smart Port would be disconnected, thereby shedding the heavy load to maintain the battery power for the more important loads. On-grid, as shown in the diagram above, the inverter can pass power from the grid to both the Smart Port load and the loads on the backup-side at the same time.

### Limitations of Using the Smart Port for Load Control:

1. The largest load that can be connected to the Smart Port is a load that requires 25 kVA of power. Most typically, an 80A EV charger or air conditioner would be the largest type of load that would be connected.
2. The load connected to the Smart Port will be supported so long as there is enough battery power stored to support it. Please be mindful when selecting a load to connect to the Smart Port that it should be a load that can be lived without when the grid is down.
3. **DO NOT connect a bi-directional EV charger to the Smart Port.**

# 8. Appendix

## Maximum Passthrough Power from Grid to Load at Night (no PV)

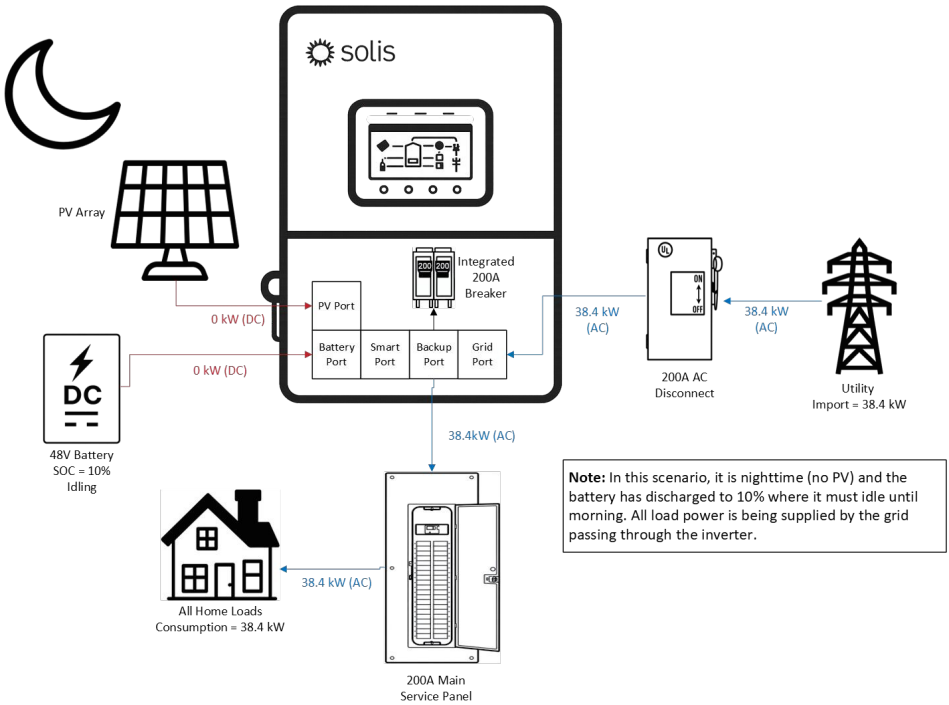

The inverter is rated for a maximum of 180A of passthrough power. Above 180A, the inverter will trip due to overload. However, per NEC rules the most amount of power that can go through a 200A breaker is 160A. Therefore, the max. amount of power that could potentially go from the grid to the loads on the backup side when there is no PV/battery power available is 160A (38.4 kW) as shown in the diagram above.

### Limitations of Passthrough Power

1. 160A is the maximum amount of continuous power that should be imported from the grid when the main breaker is rated for 200A.
2. The inverter will trip if the passthrough power exceeds 180A for more than 10 seconds.
3. Paralleling multiple inverters together increases the passthrough power capacity (for 400A or larger service panels).
4. If more than 160A of load consumption is expected, it is advised to leave some loads on the grid-side of the system.

Solis Latin America

Tel: +52 81 3434 2092

Email: [support@solislatam.freshdesk.com](mailto:support@solislatam.freshdesk.com)

If you encounter any problems with the inverter, please take note of the inverter serial number and then contact us using the phone number or email listed above.



**Compliant with CA Rule 21 & HECO Rule 14H**  
**Certified to UL 1741 SA and UL 1741 SB**  
**Certified to UL Std. No. 1741-Second Edition**  
**& CSA-C22.2 No.107.1-16**